



Chapter 9

PE Pipe Joining Procedures

Introduction

An integral part of any pipe system is the method used to join the system components. Proper engineering design of a system will take into consideration the type and effectiveness of the techniques used to join the piping components and appurtenances, as well as the durability of the resulting joints. The integrity and versatility of the joining techniques used for PE pipe allow the designer to take advantage of the performance benefits of PE in a wide variety of applications.

General Provisions

PE pipe or fittings are joined to each other by heat fusion or with mechanical fittings. PE pipe may be joined to other pipe materials by means of compression fittings, flanges, or other qualified types of manufactured transition fittings. There are many types and styles of fittings available from which the user may choose. Each offers its particular advantages and limitations for each joining situation the user may encounter. Contact with the various manufacturers is advisable for guidance in proper applications and styles available for joining as described in this document. The joining methods discussed in this chapter cover both large and small diameter pipe. Large diameter PE pipe is considered to be sizes 3" IPS (3.500" OD, Iron Pipe Size) and larger. All individuals involved in the joining PE pipe systems, whether it be using the typical heat fusion methods or employing mechanical connections, should be fully trained and qualified in accordance with applicable codes and standards and/or as recommended by the pipe or fitting manufacturer. Those assigned to making joints in PE pipe for gas applications must meet the additional requirement of compliance with U.S. Department of Transportation Pipeline Safety Regulations(10). The equipment used in the process of making heat fused joints must be designed to operate for the selected pipe and fusion procedures. Additionally, the equipment should be well maintained and capable of operating to specification.

Thermal Heat Fusion Methods

There are three types of conventional heat fusion joints currently used in the industry; Butt, Saddle, and Socket Fusion. Additionally, electrofusion (EF) joining is available with special EF couplings and saddle fittings.

The principle of heat fusion is to heat two surfaces to a designated temperature, then fuse them together by application of a sufficient force. This force causes the melted materials to flow and mix, thereby resulting in fusion. When fused according to the pipe and/or fitting manufacturers' procedures, the joint area becomes as strong as, or stronger than, the pipe itself in both tensile and pressure properties and properly fused joints are absolutely leak proof. As soon as the joint cools to near ambient temperature, it is ready for handling. The following sections of this chapter provide a general procedural guideline for each of these heat fusion methods.

Butt Fusion

The most widely used method for joining individual lengths of PE pipe and pipe to PE fittings is by heat fusion of the pipe butt ends as illustrated in Figure 1. This technique produces a permanent, economical and flow-efficient connection. Quality butt fusion joints are produced by using trained operators and quality butt fusion machines in good condition.

The butt fusion machine should be capable of:

- Aligning the pipe ends
- Clamping the pipes
- Facing the pipe ends parallel and square to the centerline
- Heating the pipe ends
- Applying the proper fusion force

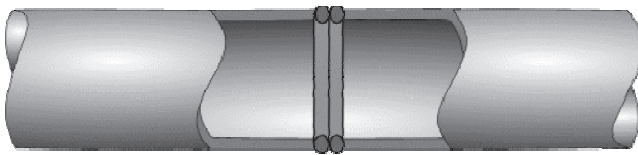

Figure 1 A Standard Butt Fusion Joint

The six steps involved in making a butt fused joint are:

1. Clean, clamp and align the pipe ends to be joined
2. Face the pipe ends to establish clean, parallel surfaces, perpendicular to the center line
3. Align the pipe ends
4. Melt the pipe interfaces
5. Join the two pipe ends together by applying the proper fusion force
6. Hold under pressure until the joint is cool

Butt Fusion of PE Pipe Products with Different Wall Thicknesses

PE pipes of the same outside diameter but having different specified wall thicknesses, that is, different DR designations, may be butt fused to each other under special conditions. Since this represents a special situation, it is subject to limitations. Therefore, the user is advised to consult with the pipe manufacturer to determine if the special procedures can be applied to the pipe components involved in the particular installation in question. If so, a written copy of the applicable assembly recommendations should be obtained.

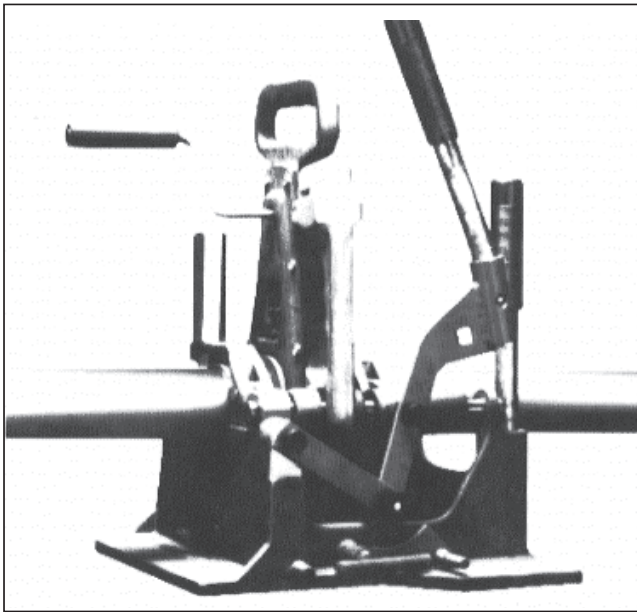

Figure 2 Typical Butt Fusion Machine for Smaller Diameter Pipe
(Butt Fusion machines are available to fuse pipe up to 65 inches in diameter)

Most pipe manufacturers have detailed parameters and procedures to follow. The majority of them helped develop and have approved the PPI Technical Report TR-33 for the generic butt fusion joining procedure for PE pipe⁽¹⁵⁾ and ASTM F 2620.

Optional Bead Removal

In some pipe systems, engineers may elect to remove the inner or outer bead of the joint. External, or both beads are removed with run-around planing tools, which are forced into the bead, then drawn around the pipe. Power planers may also be used, but care must be taken not to cut into the pipe's outside surface.

It is uncommon to remove internal beads, as they have little or no effect on flow, and removal is time-consuming. Internal beads may be removed from pipes after each fusion with a cutter fitted to a long pole. Since the fusion must be completely cooled before bead removal, assembly time is increased slightly.

Saddle/Conventional Fusion

The conventional technique to join a saddle to the side of a pipe, illustrated in Figure 3, consists of simultaneously heating both the external surface of the pipe and the matching surface of the “saddle” type fitting with concave and convex shaped heating tools until both surfaces reach proper fusion temperature. This may be accomplished by using a saddle fusion machine that has been designed for this purpose.

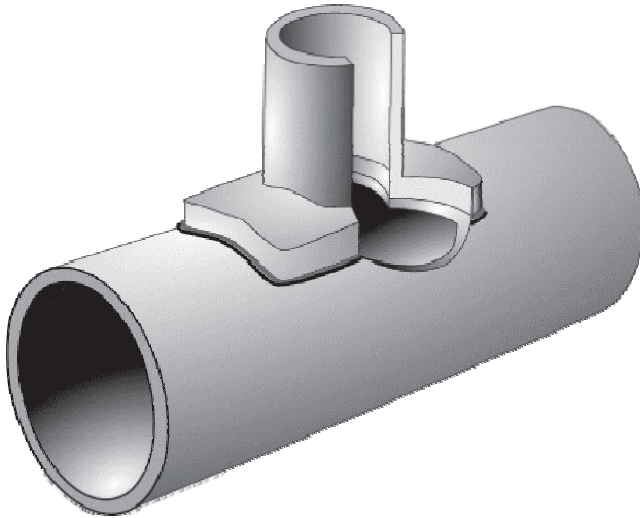

Figure 3 Standard Saddle Fusion Joint

Saddle fusion using a properly designed machine, provides the operator better alignment and force control, which is very important to fusion joint quality. The Plastics Pipe Institute recommends that saddle fusion joints be made only with a mechanical assist tool unless hand fusion is expressly allowed by the pipe and/or fitting manufacturer.⁽¹⁶⁾

There are eight basic sequential steps that are normally used to create a saddle fusion joint:

1. Clean the pipe surface area where the saddle fitting is to be located
2. Install the appropriate size heater saddle adapters

3. Install the saddle fusion machine on the pipe
4. Prepare the surfaces of the pipe and fitting in accordance with the recommended procedures
5. Align the parts
6. Heat both the pipe and the saddle fitting
7. Press and hold the parts together
8. Cool the joint and remove the fusion machine

Most pipe manufacturers have detailed parameters and procedures to follow. The majority of them helped develop and have approved the PPI Technical Report TR-41 for the generic saddle fusion joining procedure for PE pipe⁽¹⁶⁾ and ASTM 2620.

Socket Fusion

This technique consists of simultaneously heating both the external surface of the pipe end and the internal surface of the socket fitting until the material reaches the recommended fusion temperature, inspecting the melt pattern, inserting the pipe end into the socket, and holding it in place until the joint cools. Figure 4 illustrates a typical socket fusion joint. Mechanical equipment is available to hold both the pipe and the fitting and should be used for sizes larger than 2" CTS to help attain the increased force required and to assist in alignment. Most pipe manufacturers have detailed written procedures to follow. The majority refer to ASTM F 2620.

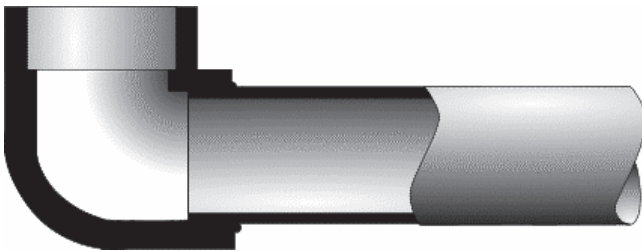

Figure 4 Standard Socket Fusion Joint

Follow these general steps when performing socket fusion:

1. Thoroughly clean the end of the pipe and the matching inside surface of the fitting
2. Square and prepare the pipe end
3. Heat the parts

4. Join the parts
5. Allow to cool

Equipment Selection

Select the proper size tool faces and heat the tools to the fusion temperature recommended for the material to be joined. For many years, socket fusion tools were manufactured without benefit of any industry standardization. As a result, variances of heater and socket depths and diameters, as well as depth gauges, do exist. More recently, ASTM F1056⁽⁷⁾ was written, establishing standard dimensions for these tools. Therefore, mixing various manufacturers' heating tools or depth gauges is not recommended unless the tools are marked "F1056," indicating compliance with the ASTM specification and, thereby, consistency of tooling sizes.

Square and Prepare Pipe

Cut the end of the pipe square. Chamfer the pipe end for sizes 1¼"-inch diameter and larger. (Chamfering of smaller pipe sizes is acceptable and sometimes specified in the instructions.) Remove scraps, burrs, shavings, oil, or dirt from the surfaces to be joined. Clamp the cold ring on the pipe at the proper position, using the integral depth gauge pins or a separate (thimble type) depth gauge. The cold ring will assist in re-rounding the pipe and provide a stopping point for proper insertion of the pipe into the heating tool and coupling during the fusion process.

Heating

Check the heater temperature. Periodically verify the proper surface temperature using a pyrometer or other surface temperature measuring device. If temperature indicating markers are used, do not use them on a surface that will come in contact with the pipe or fitting. Bring the hot clean tool faces into contact with the outside surface of the end of the pipe and with the inside surface of the socket fitting, in accordance with pipe and fitting manufacturers' instructions.

Joining

Simultaneously remove the pipe and fitting from the tool using a quick "snap" action. Inspect the melt pattern for uniformity and immediately insert the pipe squarely and fully into the socket of the fitting until the fitting contacts the cold ring. Do not twist the pipe or fitting during or after the insertion, as is the practice with some joining methods for other pipe materials.

Cooling

Hold or block the pipe in place so that the pipe cannot come out of the joint while the mating surfaces are cooling. These cooling times are listed in the pipe or fitting manufacturer's instructions.

Electrofusion (EF)

This technique of heat fusion joining is somewhat different from the conventional fusion joining thus far described. The main difference between conventional heat fusion and electrofusion is the method by which the heat is applied. In conventional heat fusion joining, a heating tool is used to heat the pipe and fitting surfaces. The electrofusion joint is heated internally, either by a conductor at the interface of the joint or, as in one design, by a conductive polymer. Heat is created as an electric current is applied to the conductive material in the fitting. Figure 5 illustrates a typical electrofusion joint. PE pipe to pipe connections made using the electrofusion process require the use of electrofusion couplings.

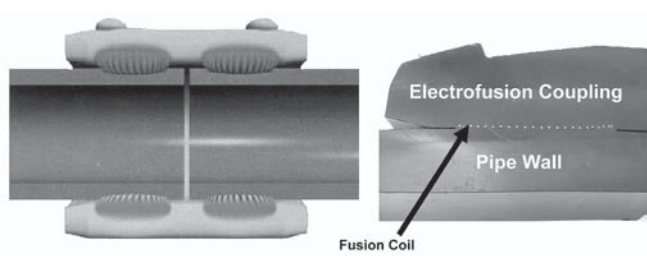

Figure 5 Typical Electrofusion Joint

General steps to be followed when performing electrofusion joining are:

1. Prepare the pipe (scrape, clean)
2. Mark the pipe
3. Align and restrain pipe and fitting per manufacturer's recommendations
4. Apply the electric current
5. Cool and remove the clamps
6. Document the fusion process

Prepare the Pipe (Clean and Scrape)

Assure the pipe ends are cut square when joining using electrofusion couplings. The fusion area must be clean from dirt or contaminants. This may require the use of water or 90% isopropyl alcohol (NO ADDITIVES OR NOT DENATURED). Next,

the pipe surface in the fusion must be scraped, that is material must be removed to expose clean virgin material. This may be achieved by various special purpose tools available from the fitting manufacturer.

Mark the Pipe

Mark the pipe for stab depth of couplings or the proper fusion location of saddles. (Caution should be taken to assure that a non-petroleum marker is used.)

Align and Restrain Pipe or Fitting Per the Manufacturer's Recommendations

Align and restrain fitting to pipe per manufacturer's recommendations. Place the pipe(s) and fitting in the clamping fixture to prevent movement of the pipe(s) or fitting. Give special attention to proper positioning of the fitting on the prepared pipe surfaces. Large pipe diameters may need re-rounding prior to the electrofusion process.

Apply Electric Current

Connect the electrofusion control box to the fitting and to the power source (see Figure 6). Apply electric current to the fitting as specified in the manufacturer's instructions. Read the barcode which is supplied with the electrofusion fitting. If the control does not do so automatically, turn off the current when the proper time has elapsed to heat the joint properly.



Figure 6 Typical Electrofusion Control Box and Leads with Clamps and Fittings

Cool Joint and Remove Clamps

Allow the joint to cool for the recommended time. If using clamps, premature removal from the clamps and any strain on a joint that has not fully cooled can be detrimental to joint performance.

Consult the fitting manufacturer for detailed parameters and procedures.

Documenting fusion

The Electrofusion control box that applies current to the fitting also controls and monitors the critical parameters of fusion, (time, temperature, & pressure). The control box is a micro-processor capable of storing the specific fusion data for each joint. This information can be downloaded to a computer for documentation and inspection of the days work.

Heat Fusion Joining of Unlike PE Pipe and Fittings

Research has indicated that PE pipe and fittings made from unlike resins can be heat-fused together to make satisfactory joints. Some gas companies have been heat-fusion joining unlike PEs for many years with success. Guidelines for heat fusion of unlike materials are outlined in TN 13, issued by the Plastics Pipe Institute. Refer to Plastics Pipe Institute Technical Reports TR-33 and TR-41, ASTM F 2620 and the pipe and fitting manufacturers for specific procedures.

As mentioned earlier, fusion joints, whether they involve the conventional butt, socket or saddle heat fusion assembly procedures or the electrofusion procedure, should only be made by personnel fully trained and qualified in those procedures. The equipment used shall be designed to operate for the selected pipe and fusion procedures. The equipment should be well maintained and capable of operating to specification. In addition, it is important that only the specified or recommended joining procedures be followed at all times during assembly operations.

Mechanical Connections

As in the heat fusion methods, many types of mechanical connection styles and methods are available. This section is a general description of these types of fittings.

The Plastics Pipe Institute recommends that the user be well informed about the performance attributes of the particular mechanical connector being utilized. Fitting selection is important to the performance of a piping system. Product performance and application information should be available from the fitting manufacturer to assist in the selection process as well as instructions for use and performance limits, if any. Additional information for these types of products is also contained in a variety of specifications such as ASTM F1924, F1973, and AWWA C219.

PE pipe, conduit and fittings are available in outside diameter controlled Iron Pipe Sizes (IPS), Ductile Iron Pipe Sizes (DIPS), Copper Tubing Sizes (CTS) and Metric Sizes. There are also some inside diameter controlled pipe sizes (SIDR-PR). Before selecting mechanical fittings, establish which of the available piping system sizes and types are being installed to ensure proper fit and function. The pipe manufacturer can provide dimensional information, and the fitting manufacturer can advise on the correct fitting selection for the application.

Mechanical Compression Couplings for Small Diameter Pipes

This style of fitting comes in many forms and materials. The components, as depicted in Figure 7, are generally a body; a threaded compression nut; an elastomer seal ring or O-ring; a stiffener; and, with some, a grip ring. The seal and grip rings, when compressed, grip the outside of the pipe, effecting a pressure-tight seal and, in most designs, providing pullout resistance which exceeds the yield strength of the PE pipe. It is important that the inside of the pipe wall be supported by the stiffener under the seal ring and under the gripping ring (if incorporated in the design), to avoid deflection of the pipe. A lack of this support could result in a loss of the seal or the gripping of the pipe for pullout resistance. This fitting style is normally used in service lines for gas or water pipe 2" IPS and smaller. It is also important to consider that three categories of this type of joining device are available. One type provides a seal only, a second provides a seal and some restraint from pullout, and a third provides a seal plus full pipe restraint against pullout.

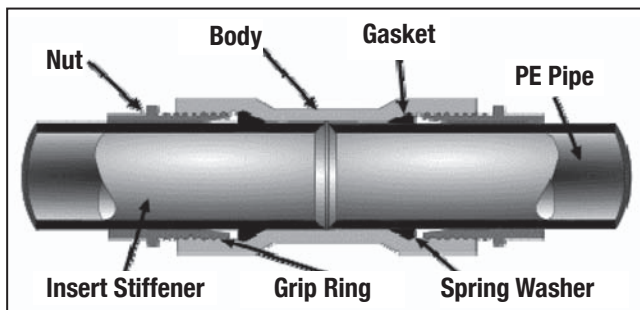

Figure 7 Typical Compression Nut Type Mechanical Coupling for Joining PE Pipe to PE Pipe

Stab Type Mechanical Fittings

Here again many styles are available. The design concept, as illustrated in Figure 8, is similar in most styles. Internally there are specially designed components including an elastomer seal, such as an "O" ring, and a gripping device to effect pressure sealing and pullout resistance capabilities. Self-contained stiffeners are included in this design. With this style fitting the operator prepares the pipe ends,

marks the stab depth on the pipe, and “stabs” the pipe in to the depth prescribed for the fitting being used. These fittings are available in sizes from ½”CTS through 2” IPS and are all of ASTM D2513⁽²⁾ Category I design, indicating seal and full restraint against pullout.

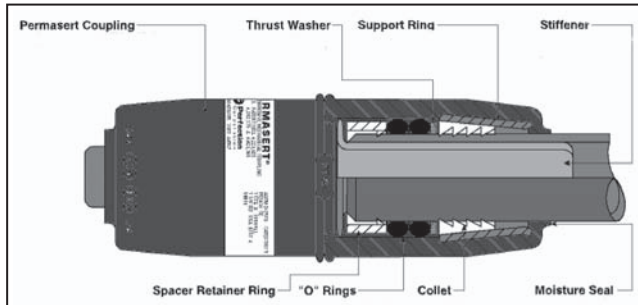

Figure 8 Stab Type Fitting

Mechanical Bolt Type Couplings

There are many styles and varieties of “Bolt Type” couplings available to join PE to PE or other types of pipe such as PVC, steel and cast iron in sizes from 1¼” IPS and larger. Components for this style of fitting are shown in Figure 9. As with the mechanical compression fittings, these couplings work on the general principle of compressing an elastomeric gasket around each pipe end to be joined, to form a seal. The gasket, when compressed against the outside of the pipe by tightening the bolts, produces a pressure seal. These couplings may or may not incorporate a grip ring, as illustrated, that provides pullout resistance sufficient to exceed the yield strength of the PE pipe. When PE pipe is pressurized, it expands a little and shortens slightly due to Poisson’s effect. In a run of PE pipe, the cumulative shortening may be enough to cause separation of unrestrained mechanical joints that are in-line with the PE pipe. This can be a particular concern where transitioning from PE pipe to Ductile Iron pipe. Joint separation can be prevented by installing external joint restraints (gripping devices or flex restraints; see Figure 16) at mechanical connections, or by installing in-line anchors or a combination of both. Additional restraint mechanisms are available to supplement the pull resistance of these types of fittings if needed. The fitting manufacturer can help guide the user with that information. Use of a stiffener is needed in this fitting style to support the pipe under the area of the seal and any gripping devices incorporated for pullout resistance.



Figure 9 Mechanical Bolt Type Coupling for Joining Steel Pipe to PE or for Joining Two PE Pipes

Stiffener Installation Guidelines

When connecting PE pipe to the bell end of a ductile iron or PVC pipe, it is recommended that a stiffener be added to the ID of the pipe to insure a good connection between the seal in the bell and the pipe. Check the pipe for toe in. If it is severe, cut the pipe back to remove it. If possible, have some means to press the stiffener into place. Lubricant will minimize the insertion effort required. A detergent or silicone grease is recommended.

There are two types of stiffeners available on the market. One type is a fixed diameter stiffener that matches the ID of the pipe being repaired (see Figure 10). Caution

should be used when using fixed diameter stiffeners to be sure they are sized properly to obtain the proper press fit in the PE pipe. These are mainly used with smaller diameter service lines.



Figure 10 Fixed Diameter Stiffener for PE Pipe



Figure 11a Split Ring Stiffener for PE Pipe

The other type of stiffener is a split ring stiffener (see Figure 11a). These are normally made of stainless steel and provide a thin yet strong pipe wall reinforcement without disturbing the flow characteristic of the pipe. The easy installation instructions are shown in Figure 11b.

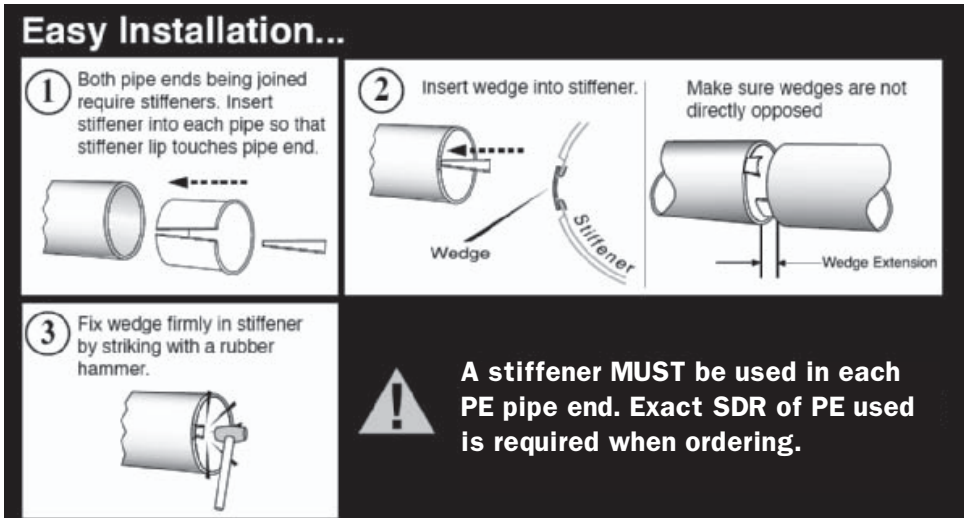

Figure 11b Easy Installation Instructions



Figure 12 Install Split Ring Stiffener in PE Pipe

Flanged Connections

PE Flange Adapters and Stub Ends

When joining to metal or to certain other piping materials, or if a pipe section capable of disassembly is required, PE flange adapters, as depicted in Figures 13-15, are available. The “Flange Adapter” and its shorter version, the “Stub End,” are designed so that one end is sized the same as the PE pipe for butt fusion to it. The other end has been especially made with a flange-type end that, provides structural

support, which eliminates the need for a stiffener and, with the addition of a metal back-up ring, permits bolting to a similar flanged end connection — normally a 150-pound ANSI flange.⁽¹⁾

The general procedures for joining would be:

1. Slip the metal ring onto the PE pipe section, far enough away from the end to avoid interference with operation of the butt fusion equipment.
2. If a stub end is used, first butt-fuse a short length of PE pipe to the pipe end of the stub end. If a “flange adapter” is used, the PE pipe-sized end is usually long enough that this step is unnecessary.
3. Butt fuse the flange adapter to the PE pipe segment.
4. The fusion bead may need to be removed to clear the back-up ring as it is moved against the flange.
5. Position the flanged face of the adapter at the position required so that the back-up ring previously placed on the PE pipe segment can be attached to the metal flange.
6. Install and tighten the flange bolts in a criss-cross pattern sequence (see TN 38), normally used with flange type connections, drawing the metal and PE flange faces evenly and flat. Do not use the process of tightening the flanges to draw the two sections of pipe together.

At lower pressure, typically 80 psi or less, a gasket is usually not required. At greater pressure, the serrated surface of the flange adapter helps hold the gasket in place. The flange face serration's should be individual closed concentric serration's as opposed to a continuous spiral groove which could act as a leak path. Standard Back-Up Rings are AWWA C207 Class D for 160 psi and lower pressure ratings, or Class 150 for higher pressure. Back-up ring materials are steel, primer coated steel, epoxy coated steel, or stainless steel. Ductile iron and fiberglass back-up ring materials are also available. In below ground service, coatings and cathodic protection may be appropriate to protect metal back-up rings from corrosion. One edge of the back-up ring bore must be rounded or chamfered. This edge fits against the back of the sealing surface flange.

An all-PE flange without a back-up ring is not recommended because PE flanges require uniform pressure over the entire sealing surface. Without a back-up ring, a PE flange will leak between the bolts.

Flange adapters differ from stub-ends by their overall length. A flange adapter is longer allowing it to be clamped in a fusion machine like a pipe end. The back-up ring is fitted to the flange adapter before fusion, so external fusion bead removal is not required.

A stub end is short and requires a special stub-end holder for butt fusion. Once butt fused to the pipe, the external bead must be removed so the back-up ring can be fitted behind the sealing surface flange. In the field, flange adapters are usually preferred over stub-ends.



Figure 13 Flange Adapter Assembly

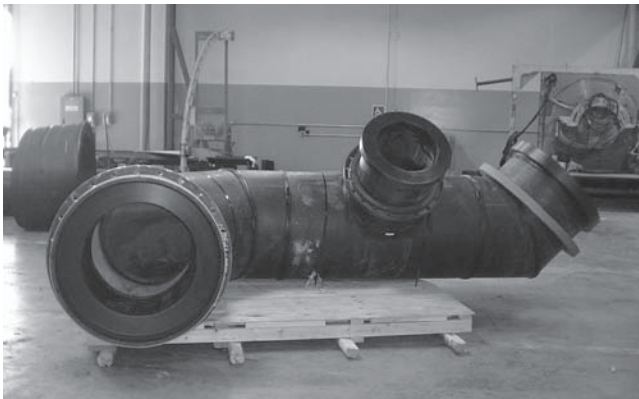

Figure 14 Fused Manifold Assembly with Flange Adapters and Back Up Rings

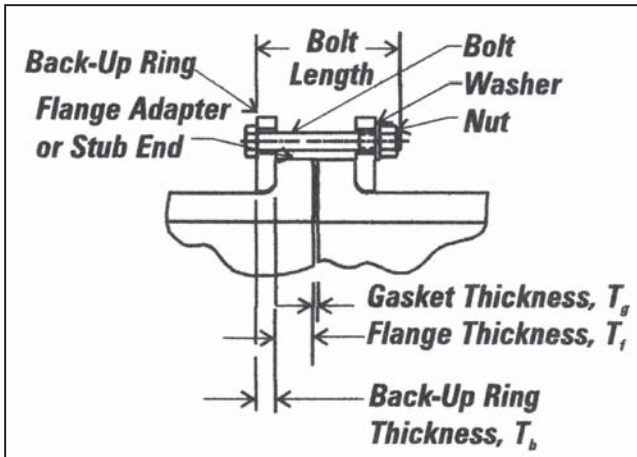

Figure 15 Flange Adapter Bolted Assembly Cross Section

Flange Gasket

A flange gasket may not be required between PE flanges. At lower pressures (typically 80 psi or less) the serrated flange sealing surface may be adequate. Gaskets may be needed for higher pressures and for connections between PE and non-PE flanges. If used, gasket materials should be chemically and thermally compatible with the internal fluid and the external environment, and should be of appropriate hardness, thickness and style. Elevated temperature applications may require higher temperature capability. Gasket thickness should be about 1/8"-3/16" (3-5mm) and about 60-75 Shore A hardness. Too soft or too thick gaskets may blow out under pressure. Overly hard gaskets may not seal. Common gasket styles are full-face or drop-in. Full-face style gaskets are usually applied to larger sizes, because flange bolts hold a flexible gasket in place while fitting the components together. Drop-in style gaskets are usually applied to smaller pipe sizes.

Flange Bolting

Mating flanges are usually joined together with hex bolts and hex nuts, or threaded studs and hex nuts. Bolting materials should have tensile strength equivalent to at least SAE Grade 3 for pressure pipe service, and to at least SAE Grade 2 for non-pressure service. Corrosion resistant materials should be considered for underground, underwater, or other corrosive environments. Flange bolts are sized 1/8" smaller than the bolt hole diameter. Flat washers should be used between the nut and the back-up ring.

Flange bolts must span the entire width of the flange joint, and provide sufficient thread length to fully engage the nut.

Flange Assembly

Mating flanges must be aligned together before tightening. Tightening misaligned flanges can cause flange assembly failure. Surface or above grade flanges must be properly supported to avoid bending stresses. Below grade flange connections to heavy appurtenances such as valves or hydrants, or to metal pipes, require a support foundation of compacted, stable granular soil (crushed stone), or compacted cement stabilized granular backfill, or reinforced concrete. Flange connections adjacent to pipes passing through structural walls must be structurally supported to avoid shear loads.

Prior to fit-up, lubricate flange bolt threads, washers, and nuts with a non-fluid lubricant. Gasket and flange sealing surfaces must be clean and free of significant cuts or gouges. Fit the flange components together loosely. Hand-tighten bolts and re-check alignment. Adjust alignment if necessary. Flange bolts should be tightened to the same torque value by turning the nut. Tighten each bolt according to the patterns and torques recommended by the flange manufacturer. PE and the gasket (if used) will undergo some compression set. Therefore, retightening is recommended

about an hour or so after torquing to the final torque value the first time. In criss-cross pattern sequence, retighten each bolt to the final torque value. For high pressure or environmentally sensitive or critical pipelines, a third tightening, about 4 hours after the second, is recommended.

Special Cases

When flanging to brittle materials such as cast iron, accurate alignment, and careful tightening are necessary. Tightening torque increments should not exceed 10 ft.-lbs. PE flange adapters and stub ends are not full-face, so tightening places a bending stress across the flange face. Over-tightening, misalignment, or uneven tightening can break brittle material flanges.

When joining a PE flange adapter or stub end to a flanged butterfly valve, the inside diameter of the pipe flange should be checked for valve disk rotation clearance. The open valve disk may extend into the body of the flange adapter/stub end. Valve operation may be restricted if the pipe flange interferes with the disk. If disk rotation clearance is a problem, a tubular spacer may be installed between the mating flanges, or the pipe flange bore may be chamfered slightly. At the sealing surface, chamfering must not increase the flange inside diameter by more than 10%, and not extend into the flange more than 20% of the flange thickness. If spacer plates are used, the flange bolt length must be increased by the length of the spacer.

Mechanical Flange Adapters

Mechanical Flange Adapters are also available and are shown in Figure 16. This fitting combines the mechanical bolt type coupling shown in Figure 9 on one end with the flange connection shown in Figure 10 on the other. This fitting can provide a connection from flange fittings and valves to plain end pipes. The coupling end of this fitting must use a stiffener when used to join PE pipe. Mechanical flange adapters may or may not include a self-restraint to provide restraint against pipe pullout as part of the design. Alternative means of restraint should be used when joining PE pipe if the mechanical flange adapter does not provide restraint. Contact the manufacturer of these fittings for assistance in selecting the appropriate style for the application.

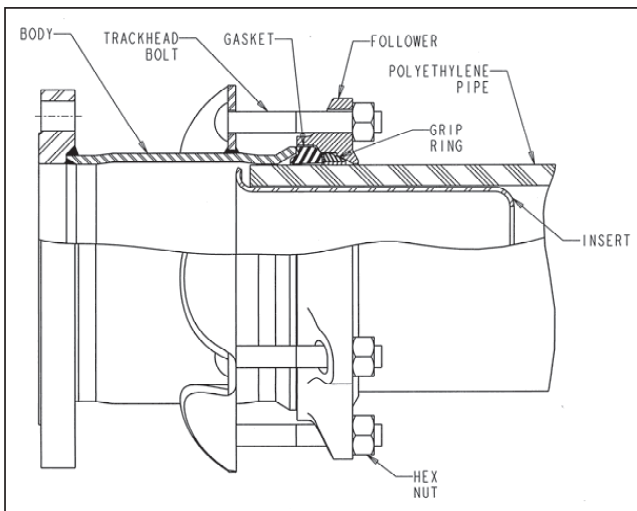

Figure 16 Bolt Type Mechanical Flange Adapter

Solid DI Sleeve Connections to PE pipe

Solid Sleeves are ductile iron fittings designed to connect DI/PVC pipe to other piping materials including PE pipe. They come in a variety of configurations depending on the application. Most solid sleeves have a flange or MJ hub to attach to the PE pipe. On the ductile iron pipe side, a Megalug flange is attached to the pipe and a gasket is installed over the pipe and into the sleeve before bolting the Megalug to the Sleeve flange. A standard PE MJ Adapter kit is used on the PE pipe side to complete the assembly. Be sure to use the manufacturer's recommended bolting procedures for this assembly. (See Figure 17.)

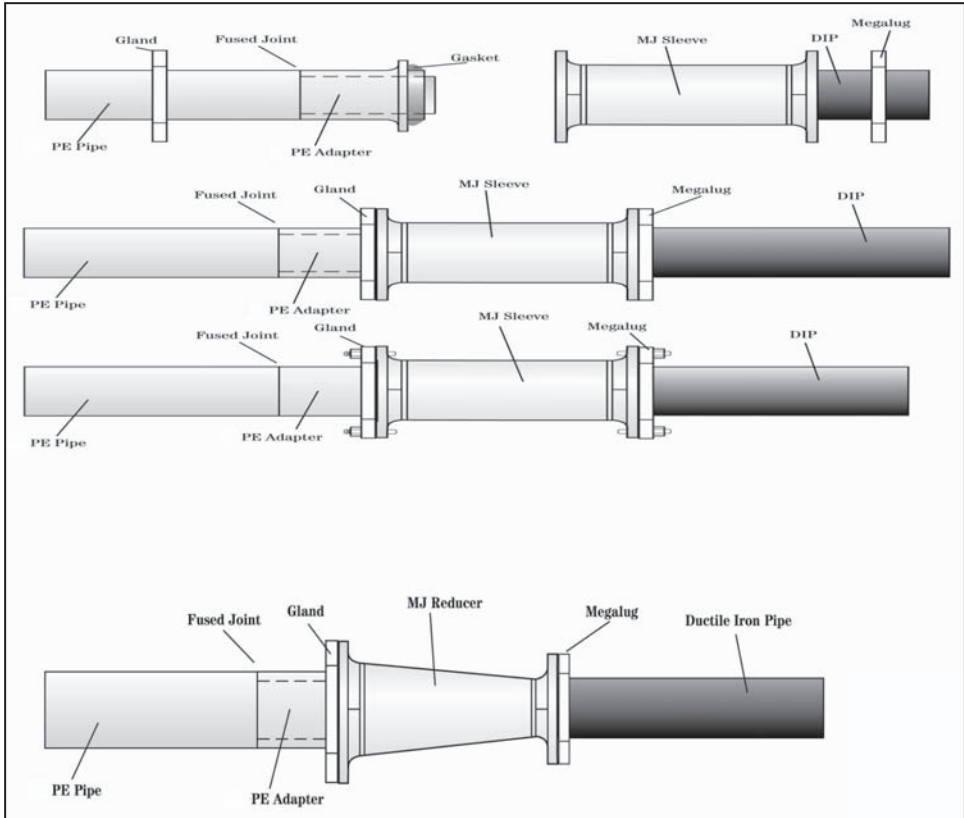

Figure 17 Solid DI Sleeve Connections to PE pipe

Another solid sleeve design is called a “One Bolt” Solid Sleeve and can be used to connect PE pipe to PVC or DI pipe. This is similar to a standard PE mechanical connector but has a special locking ring that grips the PE pipe to prevent pullout. It is recommended to use a stiffener inside the PE pipe, especially if the DR is more than 11. This connection can be installed very quickly in the field and may also be used for repair. Consult with the sleeve manufacturer for application and restraint advice.



Figure 18 One Bolt Solid Sleeve Connection

PE Pipe Connection to DI or PVC Bell End

Another method of restraining the above mentioned connection would be the use of a restraint harness and the attachment of flex restraint sections to the PE pipe. These flex restraint pieces are electro-fused to the PE pipe to achieve the proper stab depth in the PVC or DI bell and the restraint harness plate is attached behind them. The opposite end of the restraint harness is attached behind the DI/PVC hub. Install the PE pipe in the PVC/DI bell until it bottoms out on the flex restraints and tighten the tie rods to prevent the assembly from pulling apart. As discussed above: to maintain proper contact with the seal in the DI/PVC fitting, it is recommended that a stiffener be installed in the PE pipe end.

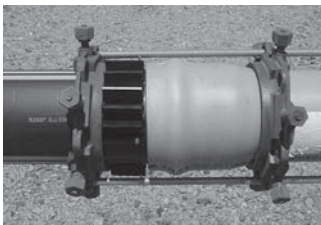

Figure 19 PE Pipe Connection to DI/PVC Bell End Using Flex Restraints on the PE Pipe

PE Bell Adapters to DI or PVC Pipe End

There are PE Bell Adapters available, up to 24" IPS, that are machined to the standard MJ Adapter internal configurations and have an external stainless steel backup ring installed to ensure positive seal contact. This connection incorporates a back-

up flange behind the PE Adapter and a Mega-Lug flange on the PVC or DI pipe. Standard MJ seals and bolts are used to connect the assembly.



Figure 20 PE Bell Adapter to DI or PVC Pipe End

DI Valve with PE Ends

In most potable water systems, a valve is installed between the main and the hydrant. This can be fused in line using this special valve assembly with PE pipe installed on each side and available up to 12" pipe size. It has an PE ends installed on each side of the valve.

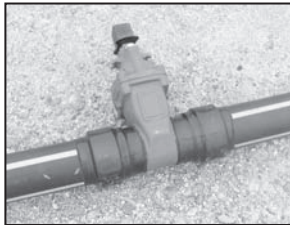

Figure 21 Ductile Iron Gate Valve with PE Ends

Dismantling Joint

Dismantling joints simplify installations and replacement of flanged fittings in retrofitting applications. Dismantling Joints provide the solution for adding, repairing or replacing flanged fittings within a flanged pipe system. In all applications, a restrained dismantling joint is required unless otherwise specified. (See Section titled Restraint Methods.)

Adjustable, slip joint design accommodates either wide gaps or close quarter installations and eliminates the need for precise measurements between flange connections. Available in sizes 2" and larger, for ductile iron or flanged PE piping systems. Standard flanges AWWA C207 Class D Flange. Other flanges are available upon request.



Figure 22 Dismantling Joint

Mechanical Joint (MJ) Adapters

PE pipe can be connected to traditional hydrants, valves and metal pipes using an MJ Adapter. A gland ring is placed behind the adapter before fusing, which can be connected to a standard ANSI/AWWA mechanical joint. When the gland ring is used, restraining devices are not required on the PE pipe.

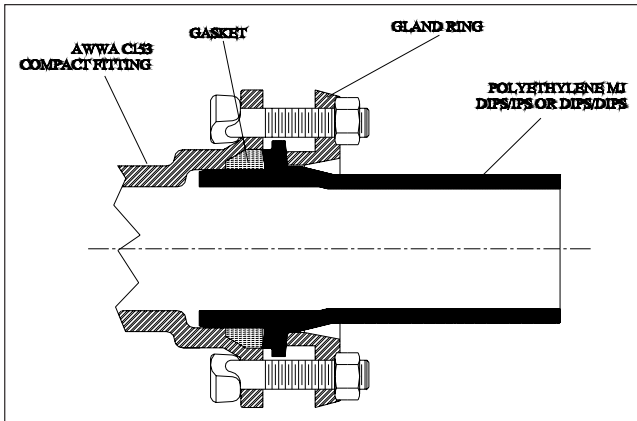

Figure 23 Typical Application of PE MJ Adapter

Transition Fittings

Other methods are available that allow joining of PE to metal. Transition fittings are available which are pre-assembled at the manufacturer's facility. These transition fittings are normally pull-out resistant, seal tight with pressure and have tensile values greater than that of the PE pipe part of a system. However, the user should insist on information from the manufacturer to confirm design capabilities or limitations. Transition fittings are available in all common pipe sizes and PE materials from CTS and larger with a short segment of PE pipe for joining to the PE pipe section. The metal end is available with a bevel for butt welding, with male or female pipe threads, or is grooved for a Victaulic⁽¹⁴⁾ style, or flanged for connecting to an ANSI 150-pound flange.⁽¹⁾

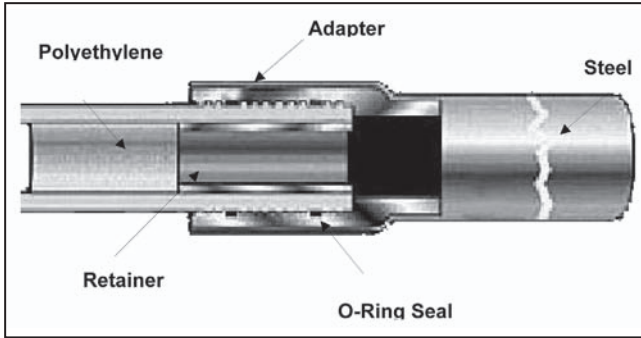

Figure 24 Standard Fitting for PE Pipe to Steel Pipe Transition

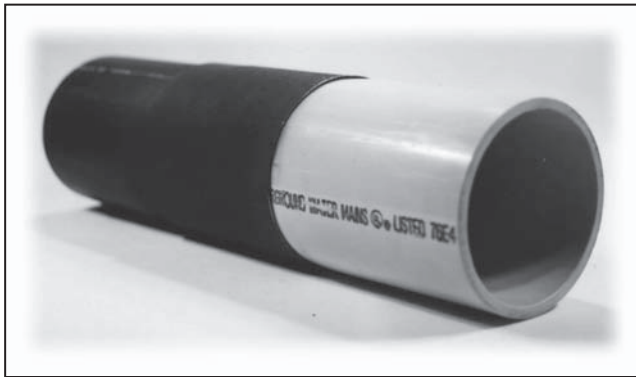

Figure 25 Transition Fitting - PE Pipe to PVC



Figure 26 Transition Fitting - PE Pipe to DI with MJ Adapter



Figure 27 Hydrant Swivel Transition Fitting - PE Pipe to DI

Mechanical Joint Saddle Fittings

Mechanical joint saddle fittings have at least one mechanical joint which may connect the outlet to the service or branch pipe, or may connect the fitting base to the main, or both connections may be mechanical joints. Mechanical joint saddle fittings are made from PE, metals, and other materials.

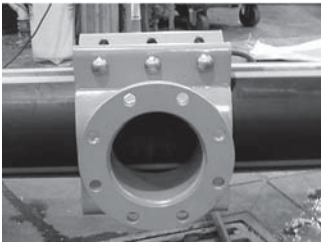

Figure 28 Mechanical Saddle

For mechanical joint outlets, the service or branch pipe is either supported with a tubular stiffener in the pipe ID, or the pipe end is fitted over a spigot (insert) end of the fitting. The outlet joint is completed using mechanical compression around the service or branch pipe OD. Depending upon design, gaskets may or may not be used. Observe the fitting manufacturer's instructions in making the outlet connection.

Plastic outlet pipes must be protected against shear or bending loads by installing protective sleeves or bridging sleeves, or special care must be taken to ensure that embedment materials are properly placed and compacted around the outlet.

The connection between the saddle base and the main may be by hot plate saddle fusion, or by electrofusion, or by mechanical connection. Hot plate saddle fusion and electrofusion have been previously discussed.

Mechanical saddle base connections are clamped or strapped to the side or top of the main pipe. Typically, gaskets or o-rings are used to seal between the saddle base and the main pipe OD surface to prevent leakage when the main wall is tapped. Once

secured to the main per the fitting manufacturer's instructions, the main may be pierced to allow flow into the service or branch pipe.

Some mechanical joint saddle fittings can have an internal cutter to pierce the main pipe wall (Fig. 28). "Tapping tees or tapping saddles" (Fig. 29) are generally suitable for installation on a "live" or pressurized main (hot tapping). Branch saddles or service saddles that do not have internal cutters may also be hot tapped using special tapping equipment. Contact equipment manufacturer for information.

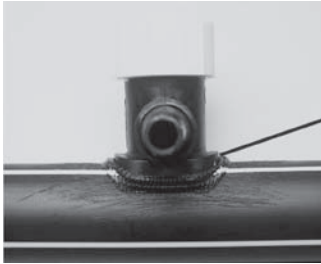

Figure 29 PE Tapping Tee with Cutter

Restraint Methods

A pipe section with fully restrained joints such as a long string of butt fused PE pipe will transmit Poisson effect pipe shortening from length to length through the restrained joints along the pipe string. Restrained joints include butt fusions, electro-fusions, socket fusions, bolted flange connections, MJ Adapter connections or other restrained mechanical connections. If an unrestrained bell and spigot or mechanical sleeve joint is in-line with the restrained section, the cumulative Poisson effect shortening and possible thermal expansion/contraction effect may cause in-line unrestrained joints or connections to be pulled apart. Therefore, unrestrained joints or mechanical connections that are in-line with fully restrained PE pipe must be either restrained or otherwise protected against pullout disjoining.

Wall Anchor

A typical pullout prevention technique is to restrain the transition connection by butt fusing a Wall Anchor in the PE pipeline close to the connection and pouring a concrete anchor around it as shown in Figure 30. Refer to the pipe manufacturer's recommendations on anchor size and pull out loads.

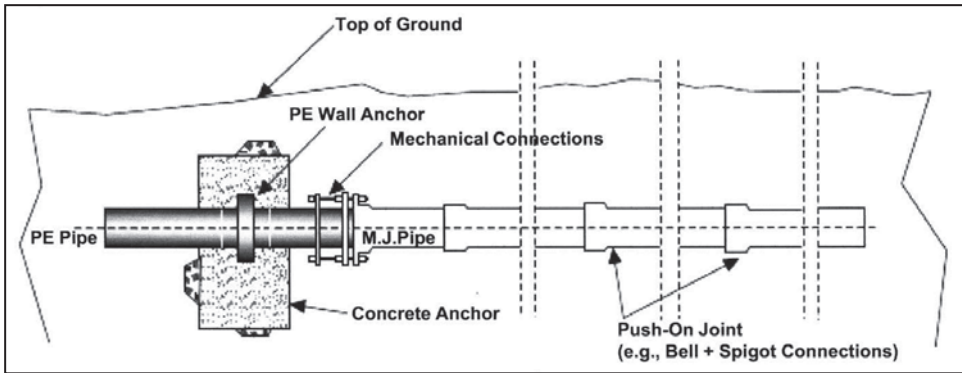

Figure 30 Wall Anchor Diagram

Another method of anchoring this connection is to electro-fuse several Flex Restraints to the PE pipe instead of butt fusing a wall anchor to the line as shown in Figure 31.

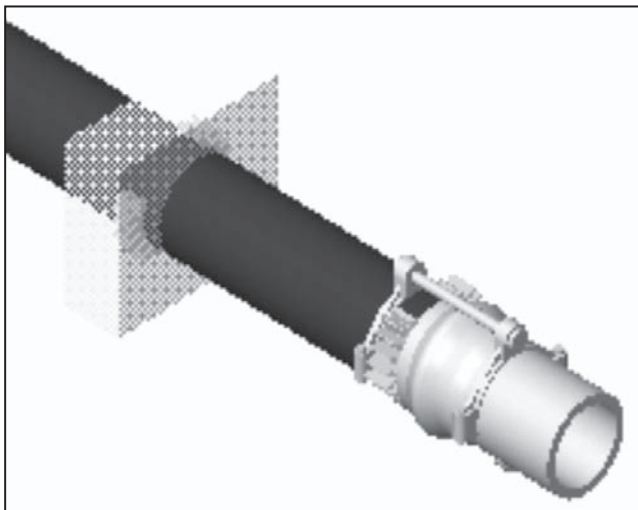

Figure 31 Flex Restraint Anchor

Mechanical Restraint Anchor

A typical pullout prevention technique is to restrain the transition connection and several non-PE bell and spigot joints down line from the transition connection as shown in Figure 32.

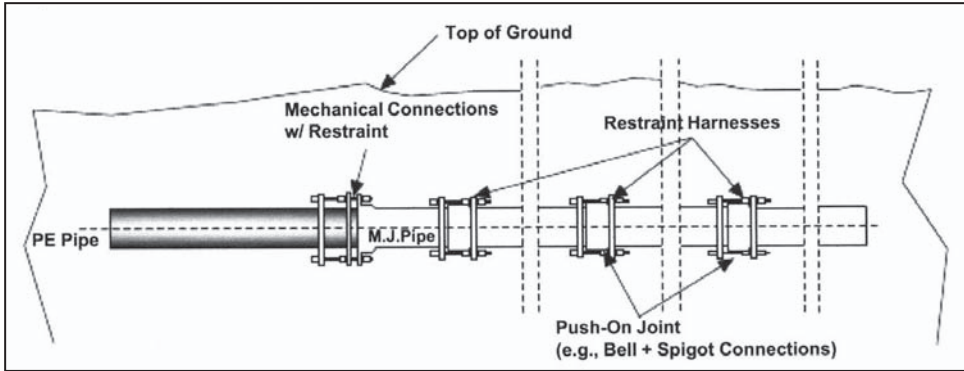

Figure 32 Mechanical Restraint of Existing Pipeline when Attaching to PE Pipe

Buried Poly Anchor

This product is designed to be buried in the soil and resist any linear movement that might occur with PE pipe without pouring a concrete anchor around it. In order to mobilize its buried anchoring restraint action, the Poly-Anchor simply requires at least 85% standard Proctor Density soil compaction in-situ to the top of the plate. Consult with the fitting manufacturer to ensure that the anchor size is adequate for the bearing capacity of the soil.

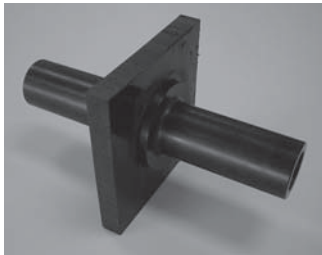

Figure 33 Buried Poly Anchor

Above Ground Pipeline Anchor

The above ground anchor fitting is commonly used to manage PE pipe from thermal expansion and contraction. The fitting is fused into the pipe-line, and a metal band (C-Clamp) is secured over the anchor fitting in the middle, and securely bolted to an I-beam, support bracket, or embedded into a concrete block up-to the spring-line with C-clamp over the pipe crown and bolted to the block. The metal band attaches the pipeline to the anchoring point; the OD rings prevent the pipeline from moving in expansion or contraction in either direction. The width of the center groove can be

made as wide as required so as to get sufficient grip on the PE pipe for the thermal excursions expected.

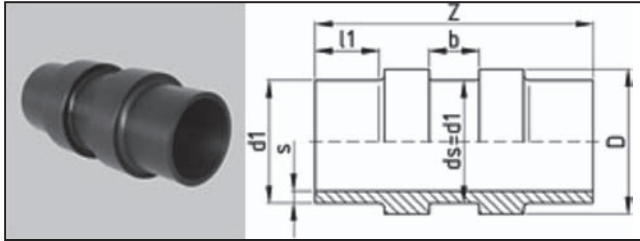

Figure 34 Above Ground Pipeline Anchor

PE to PVC Slip-Joint Anchor Fitting

A gasketed PVC pipe bell to plain end PE pipe should be restrained against PE thermal contraction and pressure thrust, to avoid possible long-term joint separation. The PVC-Bell slip-Joint Anchor Fitting (PVC-SJA Fitting) with internal stiffener to support gasket load, provides the restrained connection from PE pipe to bell-end PVC pipe. (For plain-end PVC, refer to Section titled PE Bell Adapters to DI or PVC Pipe End). When the restraint rings with tie-rod option is specified, the rods and rings are supplied separately from the SJA fitting.

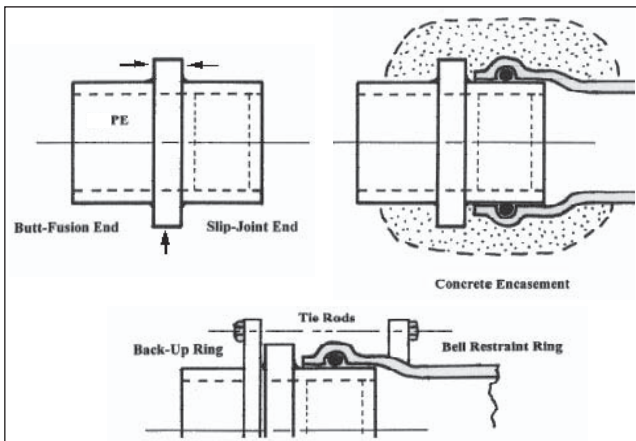

Figure 35 PE to PVC Slip-Joint Anchor Configurations

Summary

The applications for PE piping products continue to expand at an accelerating rate. Gas distribution lines, potable water systems, submerged marine installations, gravity and force main sewer systems, and various types of above-ground exposed piping systems are but a few of the installations for which PE pipe and fittings have been utilized.

As piping products applications expand, so does the use of new and existing joining methods expand.

A key element to this continued success is the diversity of methods available to join PE pipe and fittings. The integrity of the butt and socket fusion joining technique has been proven by the test of time in a variety of applications. The manufacturers of PE pipe and fittings have made every effort to make the systems as comprehensive as possible by producing a variety of fittings and components to insure compatibility with alternate piping materials and system appurtenances.

The purpose of this chapter has been to provide the reader with an overview of the various methods by which PE piping materials may be joined. As a result the reader has developed a further appreciation for the flexibility, integrity, and overall utility afforded in the design, installation, and performance of PE piping systems and components.

It should be noted that this chapter does not purport to address the safety considerations associated with the use of these procedures. Information on safe operating procedures can be obtained from the manufacturers of the various types of joining equipment or PE products.

References

1. ASME/ANSI B16.5. (1996). *American National Standard on Pipe Flanges and Flanged Fittings*, American National Standards Institute, New York, NY.
2. ASTM D2513, Standard Specifications for Thermoplastic Gas Pressure Pipe, Tubing, and Fittings, *Annual Book of Standards*, ASTM, West Conshohoken, PA.
3. ASTM F2620, " Standard Practice for Heat Fusion Joining of Polyethylene Pipe and Fittings, West Conshohoken, PA.
4. ASTM D3140, Standard Practice for Flaring Polyolefin Pipe and Tubing, *Annual Book of Standards*, ASTM, West Conshohoken, PA.
5. ASTM F894, Standard Specification for PE (PE) Large Diameter Profile Wall Sewer and Drain Pipe, *Annual Book of Standards*, ASTM, West Conshohoken, PA.
6. ASTM F1041, Standard Guide for Squeeze-Off of Polyolefin Gas Pressure Pipe and Tubing, *Annual Book of Standards*, ASTM, West Conshohoken, PA.
7. ASTM F1056, Standard Specification for Socket Fusion Tools for Use in Socket Fusion Joining PE Pipe or Tubing and Fittings, ASTM, West Conshohoken, PA.
8. AWWA C901, PE (PE) Pressure Pipe and Tubing, 1/2 in. Through 3 in., for Water Service, American Water Works Association, Denver, CO.
9. Caution Statement on Sidewall Heat Fusion Without Use of Mechanical Assist Tooling, *Statement T*. Plastics Pipe Institute, Irving, TX.
10. *Code of Federal Regulations*, Title 49, Part 192, Subpart F., Pipeline Safety Regulations, Washington, DC.
11. General Guidelines for the Heat Fusion of Unlike PE Pipes and Fittings, Report TN-13, Plastics Pipe Institute, Irving, TX.
12. IAPMO, International Association of Plumbing and Mechanical Officials, Walnut, CA.

13. PPFA. Plastics Pipe and Fittings Association, Glen Ellyn, IL.
14. *Victaulic General Catalog on Mechanical Piping Systems*. (1988). Victaulic Company of America, Easton, PA.
15. Generic Butt Fusion Procedure for PE Gas Pipe, PPI TR-33, Plastics Pipe Institute, Inc., Irving, TX.
16. Generic Saddle Fusion Procedure for PE Gas Pipe, PPI TR-41, Plastics Pipe Institute, Inc., Irving, TX.
17. AWWA C207: C207-07: Steel Pipe Flanges for Waterworks Service, Sizes 4 In. Through 144 In. (100 mm Through 3,600 mm), American Water Works Association, Denver, CO.
18. TN 38- Bolt Torque For Polyethylene Flanged Joints, Plastics Pipe Institute, Irving, TX.
19. TN 36- General Guidelines for Connecting PE Potable Water Pressure Pipes to DI and PVC Piping Systems, Plastics Pipe Institute, Irving, TX.



DRAINAGE SOLUTIONS, INC (3 1 7) 3 4 6 - 4 1 1 0
www.drainagesolutionsinc.com