

(317) 346-4110
www.drainagesolutionsinc.com

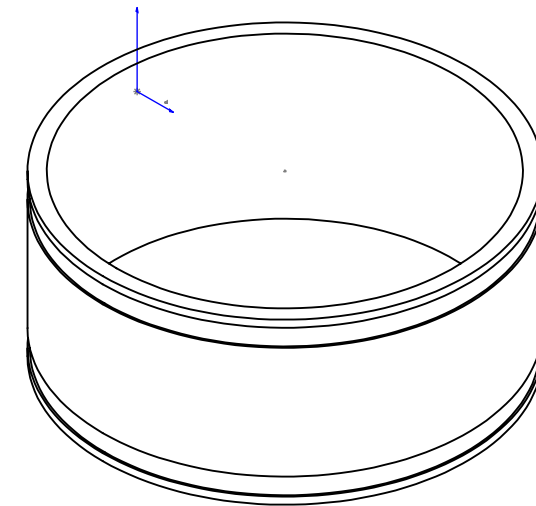

PROPRIETARY AND CONFIDENTIAL
THE INFORMATION CONTAINED IN THIS
DRAWING IS THE SOLE PROPERTY OF
FERNCO, INC. ANY REPRODUCTION IN
PART OR AS A WHOLE WITHOUT THE
WRITTEN PERMISSION OF FERNCO, INC.
IS PROHIBITED.

TOLERANCES:
.X= Fractional ±
.XX= ±.06
ANG.= +3°
UNLESS OTHERWISE SPECIFIED

Part Weight	6.33 lbs.	Installation Torque	60" Lbs.
Min/Max Temp.	-30/140 Degrees F	Conforms to ASTM	D5926, C1173
Pressure Tested	4.3 PSI	Clamps used	300 Series Stainless
Material	Flexible PVC 60 Duro Shore A	Box Quantity	5

UNITS:	INCHES
SIZE:	A
3RD ANGLE PROJECTION	
DO NOT SCALE DRAWING	

DESIGNER:	D. Brady
CHECKER:	
DATE:	7/13/2011

SCALE:	not to scale
SHEET	1 OF 1