

Q:\Technical Resources New\02--ISI\_PRODUCTS\15 - RISERS\EZsnap\Archived\EZsnap Product Specifications

# INFILTRATOR WATER TECHNOLOGIES

## EZsnap 12" RISER

(NOT TO SCALE)

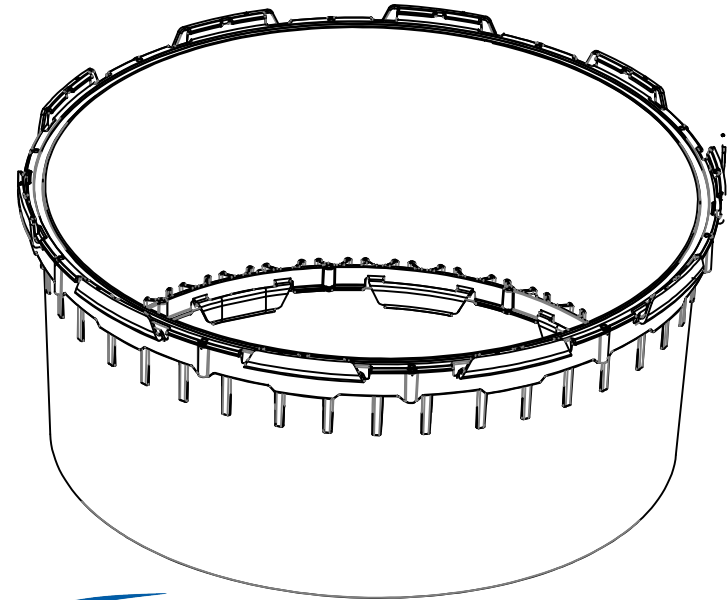
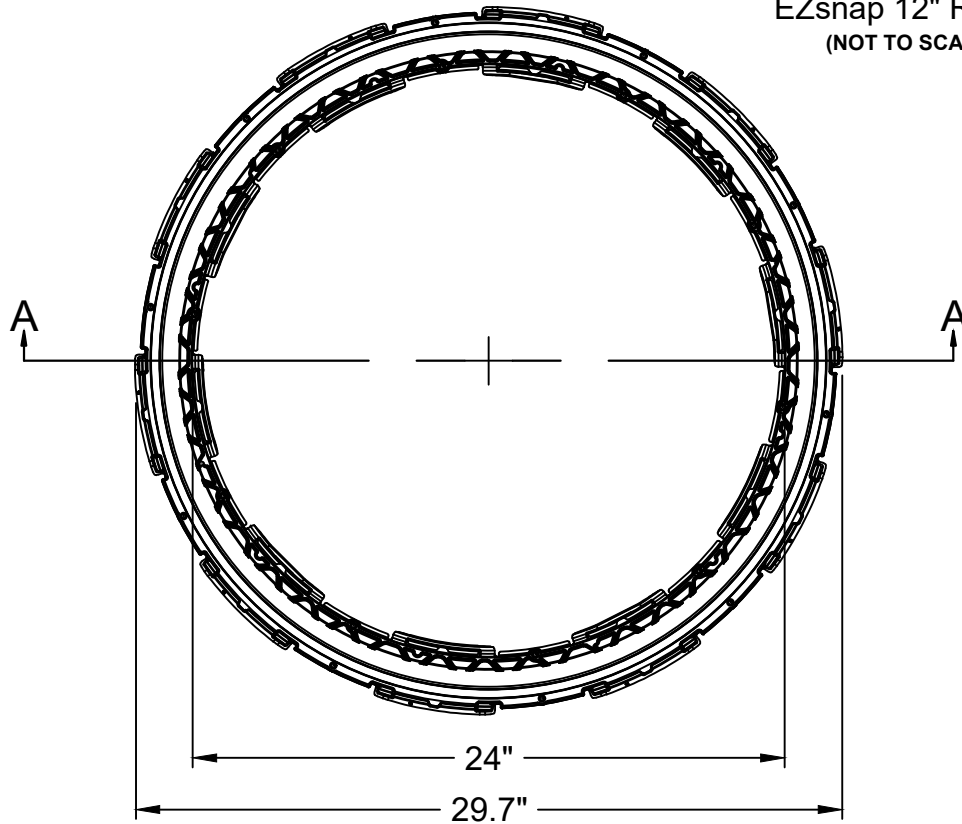

**DRAINAGE  
SOLUTIONS, INC**

(317) 346-4110

[www.drainagesolutionsinc.com](http://www.drainagesolutionsinc.com)

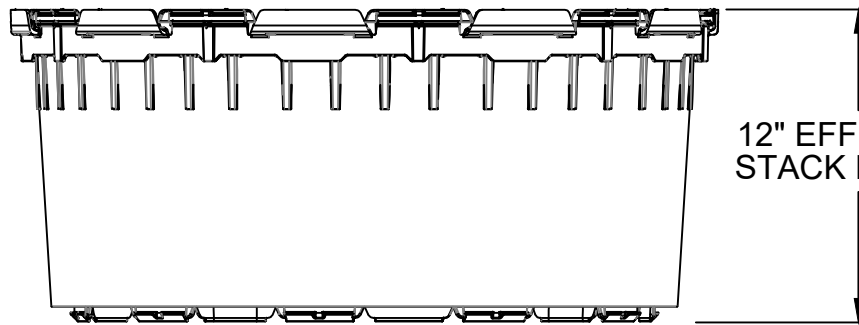

12" EFFECTIVE  
STACK HEIGHT

SECTION A-A



**INFILTRATOR**  
water technologies

INFILTRATOR WATER TECHNOLOGIES  
4 Business Park Rd, Old Saybrook, CT 06475  
(800) 221-4436

12" EZsnap RISER  
SNAPRIS - 2412

Drawn by: EMB  
Scale: NOT TO SCALE

Checked by: DFH

Date: 01/25/2017  
Sheet: 1 of 1