

INFILTRATOR WATER TECHNOLOGIES

EZsnap 2" RISER (NOT TO SCALE)

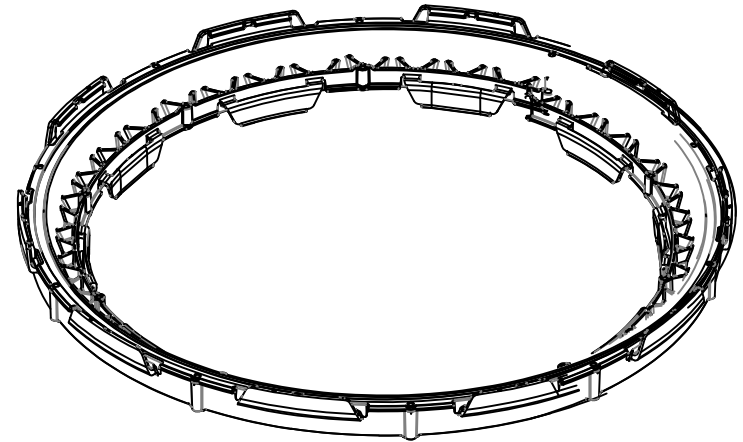

(317) 346-4110
www.drainagesolutionsinc.com

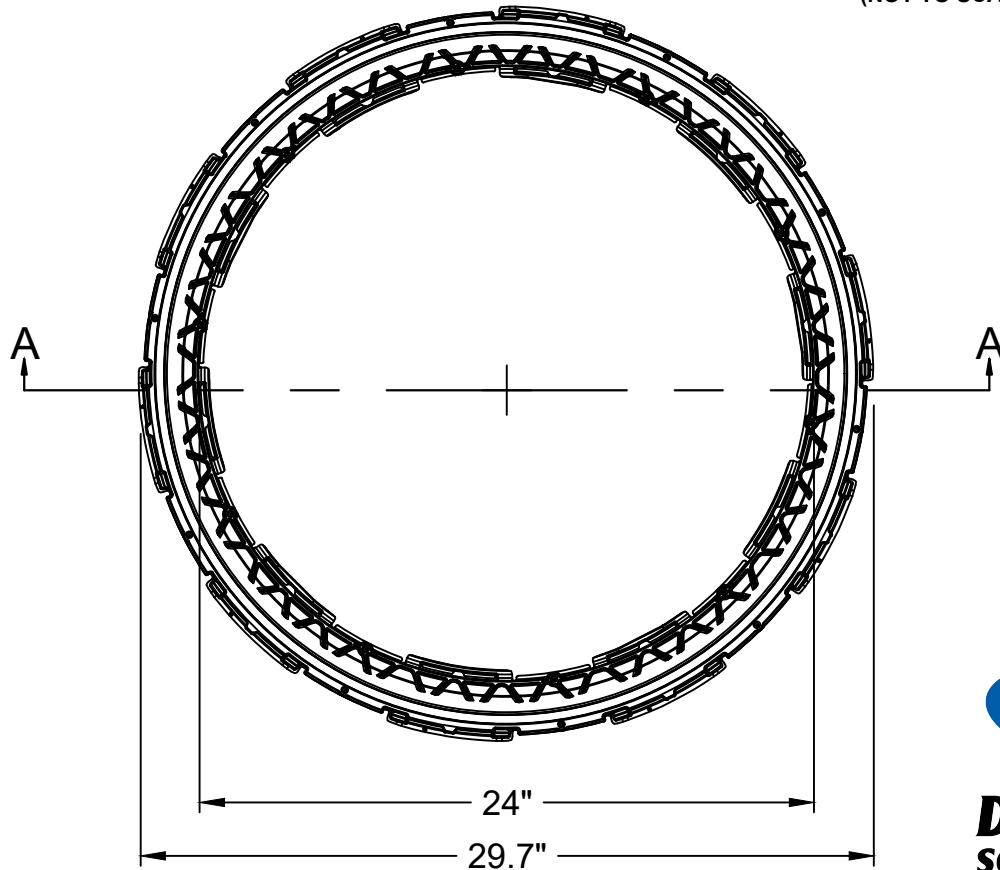
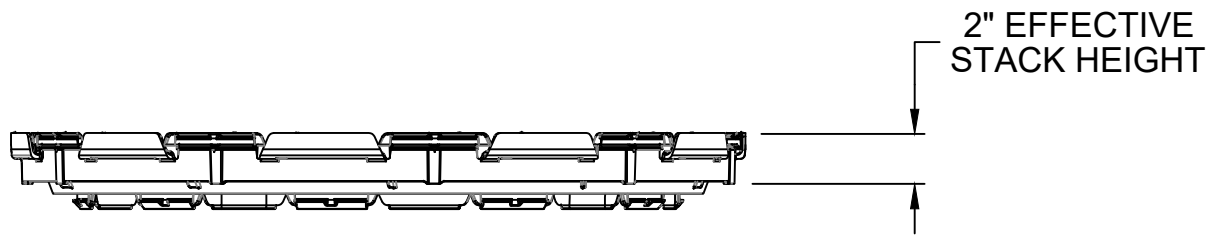

SECTION A-A

 INFILTRATOR water technologies		
INFILTRATOR WATER TECHNOLOGIES 4 Business Park Rd, Old Saybrook, CT 06475 (800) 221-4436		
2" EZsnap RISER SNAPRIS - 2412		
Drawn by: E.Alv.		Date: 02/13/2018
Scale: NOT TO SCALE	Checked by:	Sheet: 1 of 1