

TANK EXTERIOR	
LENGTH	152.3 [3,868]
WIDTH	61.7 [1,567]
HEIGHT	54.6 [1,387]

LIQUID DEPTH	44.0 [1,118]
INVERT DROP	3.0 [76]
FREEBOARD	10.0 [254]

TOTAL CAPACITY	1,479 GAL [5,599 L]
WORKING VOLUME	1,271 GAL [4,811 L]

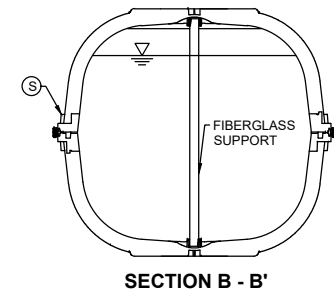
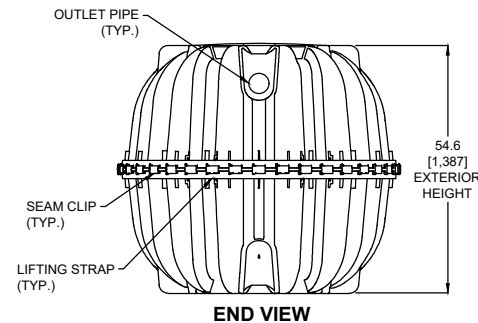

**NOTES:**

- ALL DRAWING DIMENSIONS IN INCHES [MILLIMETERS] OR AS NOTED.
- EXTERIOR OF ACCESS OPENING LID INCLUDES THE FOLLOWING WARNING IN ENGLISH, FRENCH & SPANISH: "DANGER DO NOT ENTER: POISON GASES."
- TANK MARKINGS INCLUDE: MANUFACTURER NAME, MODEL NUMBER, LIQUID CAPACITY, DATE OF MANUFACTURE, MAXIMUM BURIAL DEPTH, INLET, AND OUTLET.
- MAXIMUM BURIAL DEPTH IS 48 in [1,219 mm].
- MINIMUM BURIAL DEPTH IS 6 in [152 mm].
- TANK IS FOR NON-TRAFFIC APPLICATIONS.
- AIRSPACE IS 16.3%.
- OUTLET TEE IS COMPATIBLE WITH AN EFFLUENT FILTER.
- LENGTH TO WIDTH RATIO IS 2.8:1 (143.9-INCH LENGTH / 51.8-INCH WIDTH = 2.8).
- NOMINAL WALL THICKNESS IS 0.2 in [5 mm].

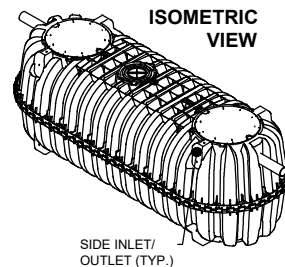

**DRAINAGE SOLUTIONS, INC**

(317) 346-4110

www.drainagesolutionsinc.com



INFILTRATOR WATER TECHNOLOGIES  
4 Business Park Rd. Old Saybrook, CT 06475  
(800) 221-4436

IM-1250  
1-Compartment  
Septic Tank Configuration

Drawn by: KAJ	Edited by: JLK	Date: 05/11/2023
Scale: NOT TO SCALE	Checked by: DJL	Sheet: 1 of 1

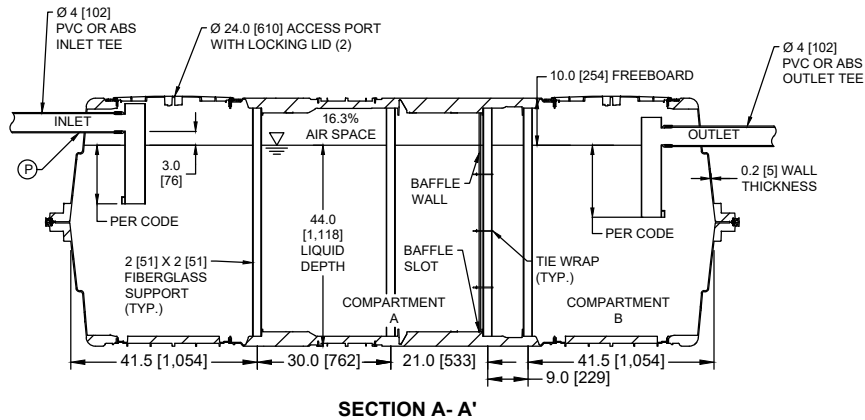
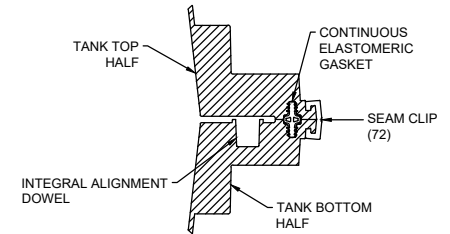
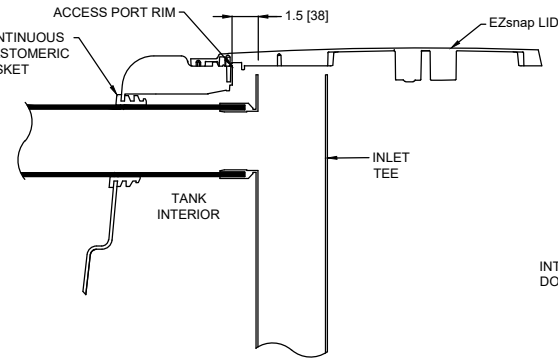
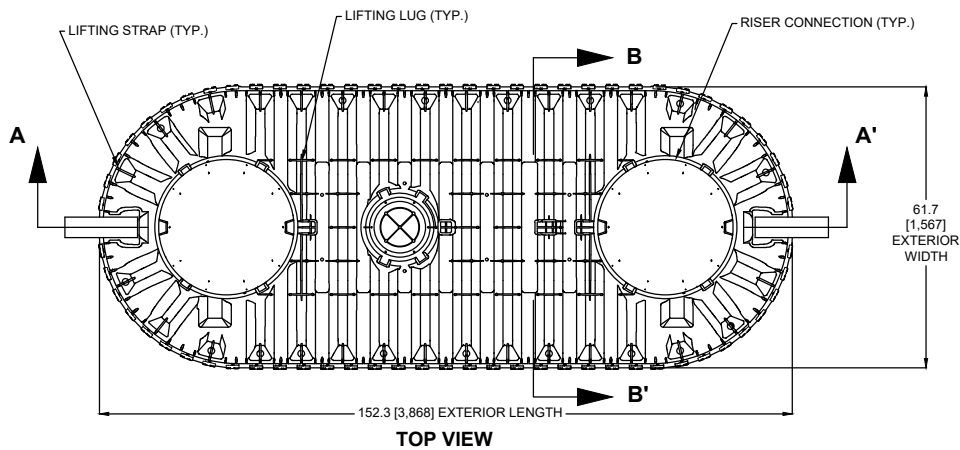

TANK EXTERIOR	
LENGTH	152.3 [3,868]
WIDTH	61.7 [1,567]
HEIGHT	54.6 [1,387]

LIQUID DEPTH	44.0 [1,118]
INVERT DROP	3.0 [76]
FREEBOARD	10.0 [254]

TOTAL CAPACITY	1,479 GAL [5,599 L]
WORKING VOLUME	1,271 GAL [4,811 L]
COMPARTMENT A VOLUME	826 GAL [3,127 L]
COMPARTMENT B VOLUME	445 GAL [1,684 L]

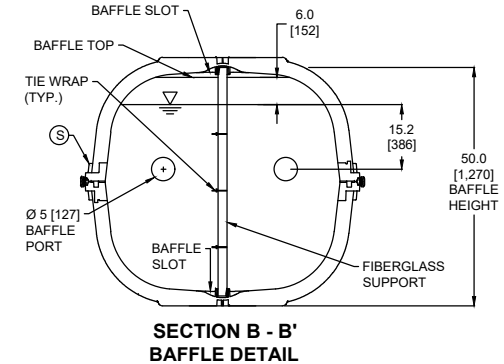
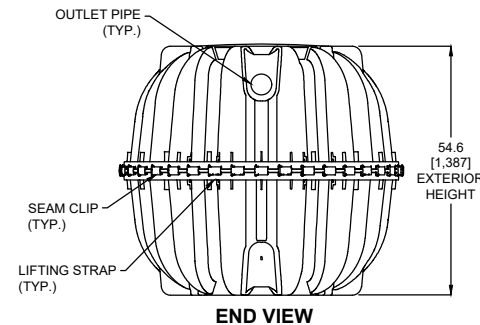

**NOTES:**

- ALL DRAWING DIMENSIONS IN INCHES [MILLIMETERS] OR AS NOTED.
- EXTERIOR OF ACCESS OPENING LID INCLUDES THE FOLLOWING WARNING IN ENGLISH, FRENCH & SPANISH: "DANGER DO NOT ENTER: POISON GASES."
- TANK MARKINGS INCLUDE: MANUFACTURER NAME, MODEL NUMBER, LIQUID CAPACITY, DATE OF MANUFACTURE, MAXIMUM BURIAL DEPTH, INLET, AND OUTLET.
- MAXIMUM BURIAL DEPTH IS 48 in [1,219 mm].
- MINIMUM BURIAL DEPTH IS 6 in [152 mm].
- TANK IS FOR NON-TRAFFIC APPLICATIONS.
- AIRSPACE IS 16.3%.
- OUTLET TEE IS COMPATIBLE WITH AN EFFLUENT FILTER.
- LENGTH TO WIDTH RATIO IS 2.8:1 (143.9-INCH LENGTH / 51.8-INCH WIDTH = 2.8).
- NOMINAL WALL THICKNESS IS 0.2 in [5 mm].
- FREE VENT AREA BETWEEN TOP OF BAFFLE WALL AND BOTTOM OF TOP BAFFLE SLOT IS 129.7 in<sup>2</sup>.
- BAFFLE WALL THICKNESS IS 0.31 in [8 mm].

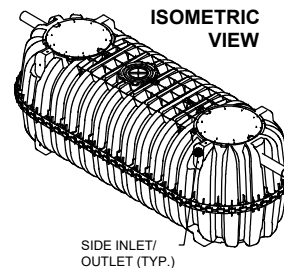

**INFILTRATOR**  
water technologies

INFILTRATOR WATER TECHNOLOGIES  
4 Business Park Rd. Old Saybrook, CT 06475  
(800) 221-4436

IM-1250  
2-Compartment  
Septic Tank Configuration

Drawn by: KAJ	Edited by: JLK	Date: 05/11/2023
Scale: NOT TO SCALE	Checked by: DJL	Sheet: 1 of 1