

The Infiltrator IM-1530 is a lightweight strong and durable septic tank. This watertight tank design is offered with Infiltrator's line of custom-fit risers and heavy-duty lids. Infiltrator injection molded tanks provide a revolutionary improvement in plastic septic tank design, offering long-term exceptional strength and watertightness.

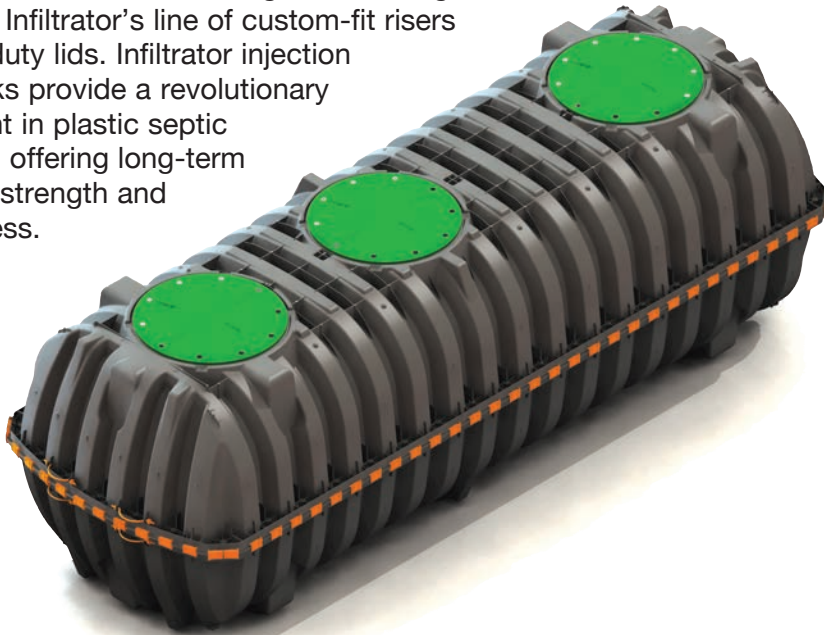

Features & Benefits

- Strong injection molded polypropylene construction
- Lightweight plastic construction and inboard lifting lugs allow for easy delivery and handling
- Integral heavy-duty green lids that interconnect with TW™ risers and pipe riser solutions
- Structurally reinforced access ports eliminate distortion during installation and pump-outs
- Reinforced structural ribbing and fiberglass bulkheads offer additional strength
- Can be installed with 6" to 48" of cover
- Can be pumped dry during pump-outs
- Suitable for use as a septic tank, pump tank, or rainwater (non-potable) tank
- No special water filling requirements are necessary
- The tank may be backfilled with suitable native soil. See installation instructions for guidance.

TANK CUTAWAY

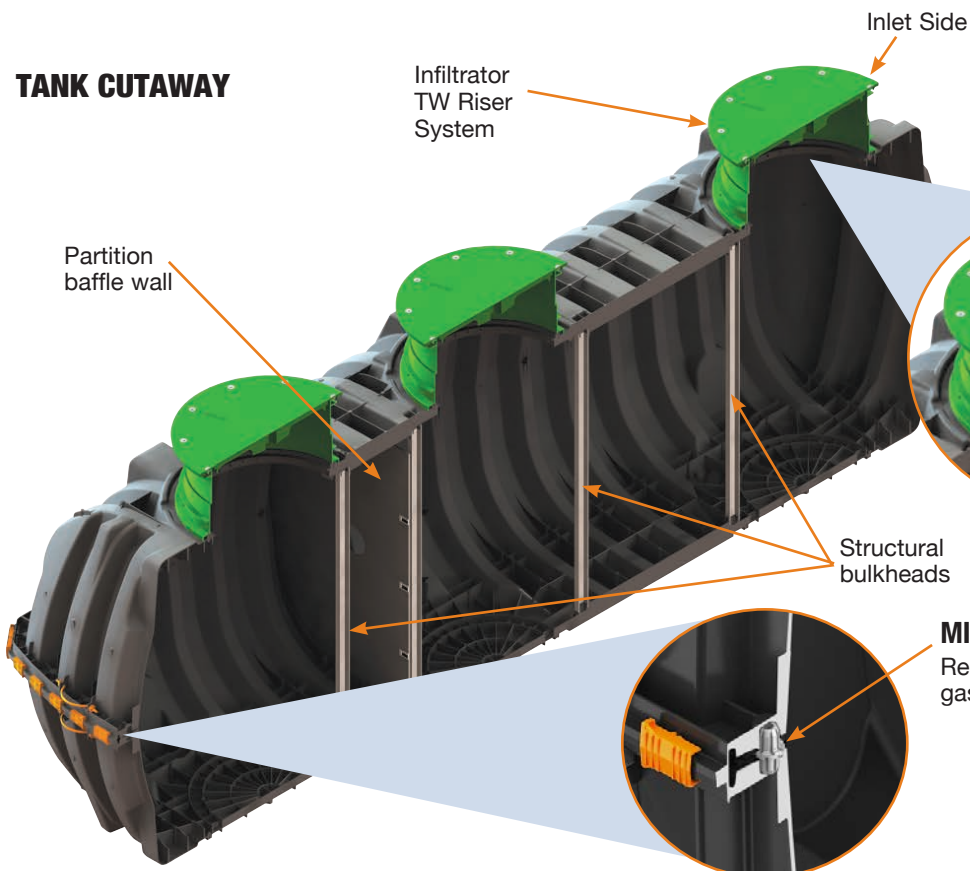

HEAVY DUTY LID CUTAWAY

Reinforced 24" structural access port

MID-SEAM CUTAWAY

Reinforced water tight mid-seam gasketed connection

IM-1530 General Specifications and Illustrations

The IM-1530 is an injection molded two piece mid-seam plastic tank. The IM-1530 injection molded plastic design allows for a mid-seam joint that has precise dimensions for accepting an engineered EPDM gasket. Infiltrator's gasket design utilizes technology from the water industry to deliver proven means of maintaining a watertight seal.

The two-piece design is permanently fastened using a series of non-corrosive plastic alignment dowels and locking seam clips. The IM-1530 is assembled and sold through a network of certified Infiltrator distributors.

Must be backfilled and installed in accordance with Infiltrator Water Technologies, Infiltrator IM-Series Septic Tank General Installation Instructions and for shallow ground water conditions reference the Infiltrator IM-Series Tank Buoyancy Control Guidance.

Please visit www.infiltratorwater.com/images/pdf/ManualsGuides/TANK01.pdf for the latest information.

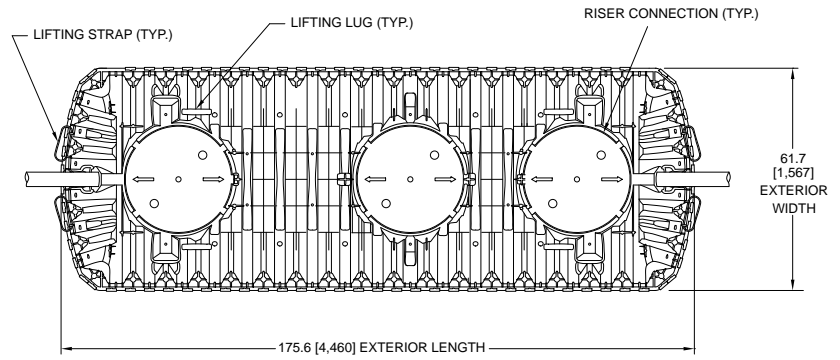

TOP VIEW

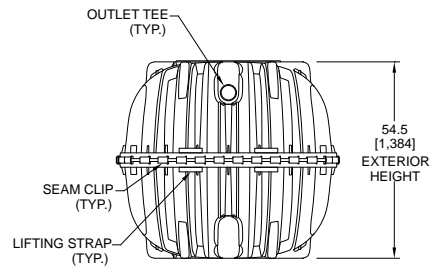

END VIEW

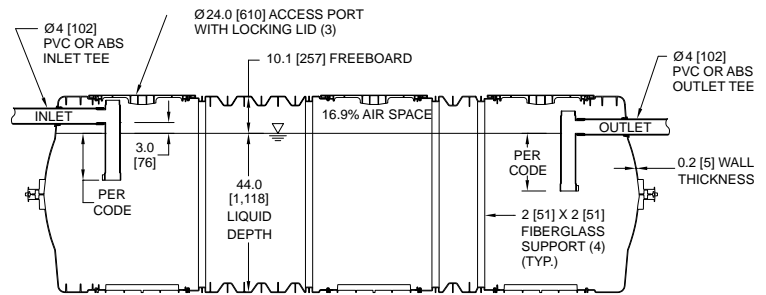

SIDE VIEW

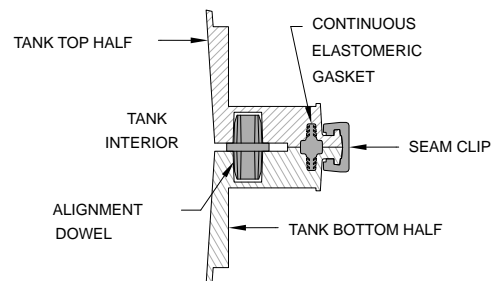

MID-HEIGHT SEAM SECTION

IM-1530	
Working Capacity	1537 gal (5818 L)
Total Capacity	1787 gal (6765 L)
Airspace	16.9%
Length	176" (4460 mm)
Width	62" (1567 mm)
Length-to-Width Ratio	2.8 to 1
Height	55" (1384 mm)
Liquid Level	44" (1118 mm)
Invert Drop	3" (76 mm)
Fiberglass Supports	4
Compartments	1 or 2
Maximum Burial Depth	48" (1219 mm)
Minimum Burial Depth	6" (152 mm)
Maximum Pipe Diameter	4" (100 mm)
Weight	501 lbs (228 kg)



(317) 346-4110

INFILTRATOR
water technologies

www.drainagesolutionsinc.com

U.S. Patents: 4,759,661; 5,017,041; 5,156,488; 5,336,017; 5,401,116; 5,401,459; 5,511,903; 5,716,163; 5,588,778; 5,839,844 Canadian Patents: 1,329,959; 2,004,564 Other patents pending. Infiltrator, Equalizer, Quick4, and SideWinder are registered trademarks of Infiltrator Water Technologies. Infiltrator is a registered trademark in France. Infiltrator Water Technologies is a registered trademark in Mexico. Contour, MicroLeaching, PolyTuff, ChamberSpacer, MultiPort, PosiLock, QuickCut, QuickPlay, SnapLock and StraightLock are trademarks of Infiltrator Water Technologies. PolyLok is a trademark of PolyLok, Inc. TUF-TITE is a registered trademark of TUF-TITE, INC. Ultra-Rib is a trademark of IPEX Inc.

© 2014 Infiltrator Water Technologies, LLC. All rights reserved. Printed in U.S.A.

IM21 1116

Contact Infiltrator Water Technologies' Technical Services Department for assistance at 1-800-221-4436