



Features & Benefits

- Strong injection molded polypropylene construction
- Lightweight plastic construction and inboard lifting lugs allow for easy delivery and handling
- Integral heavy-duty green lids that interconnect with EZsnap risers and pipe riser solutions
- Structurally reinforced access ports eliminate distortion during installation and pump-outs
- Reinforced structural ribbing offers additional strength
- Can be installed with 6" to 52" (152 to 1,321 mm) of cover
- Can be pumped dry during pump-outs
- Suitable for use as a pump tank, or rainwater (non-potable) tank
- No special water filling requirements are necessary
- The tank may be backfilled with suitable native soil. See installation instructions for guidance.

The Infiltrator IM-300 is a lightweight, strong and durable pump tank. This watertight tank design is offered with Infiltrator's line of custom-fit EZsnap risers and heavy-duty lids. Infiltrator injection molded tanks provide a revolutionary improvement in plastic tank design, offering exceptional long-term strength and watertightness.

TANK CUTAWAY

Infiltrator
EZsnap
Riser
System



HEAVY DUTY LID CUTAWAY

Reinforced 24" structural
access port

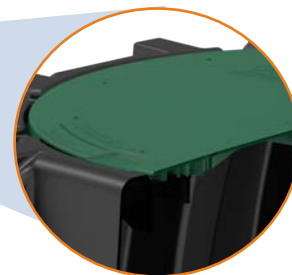

MID-SEAM CUTAWAY

Reinforced water tight
mid-seam gasketed
connection



IM-300 General Specifications and Illustrations

The IM-300 is an injection molded two-piece mid-seam polypropylene tank. The IM-300 injection molded design allows for a mid-seam joint that has precise dimensions for accepting an engineered EPDM gasket. The engineered mid-seam joint accepts a continuous loop EPDM gasket. Infiltrator's EPDM gasket design utilizes technology and materials from the sanitary sewer pipe industry to deliver a reliable watertight seal. The two-piece design is permanently fastened using a system of molded-in alignment dowels and locking seam clips. The IM-300 is assembled and sold through a network of certified Infiltrator distributors.



Must be backfilled and installed in accordance with the Infiltrator IM- and CM-Series Septic Tank General Installation Instructions. For shallow ground water conditions reference the Infiltrator IM- and CM-Series Tank Buoyancy Control Guidance.

Please visit www.infiltratorwater.com or scan QR code for the latest information.

IM-300	
Working Capacity	278 gal (1052 L)
Total Capacity	322 gal (1219 L)
Length	50.9" (1293 mm)
Width	50.9" (1293 mm)
Length-to-Width Ratio	1/1
Height	50.5" (1283 mm)
Invert Height	43.25" (1098 mm)
Liquid Level	41.25" (1048 mm)
Invert Drop	2" (50.8 mm)
Compartments	1
Maximum Burial Depth	52" (1321 mm)
Minimum Burial Depth	6" (152 mm)
Maximum Pipe Diameter	4" (102 mm)
Weight	110 lbs (50 kg)

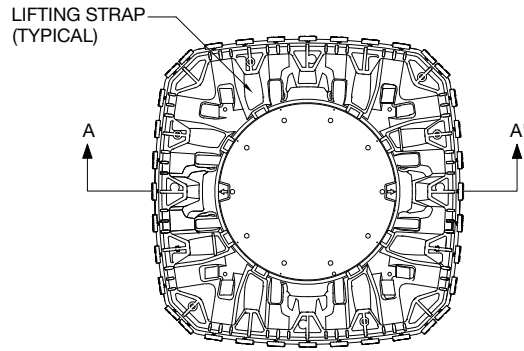

TOP VIEW

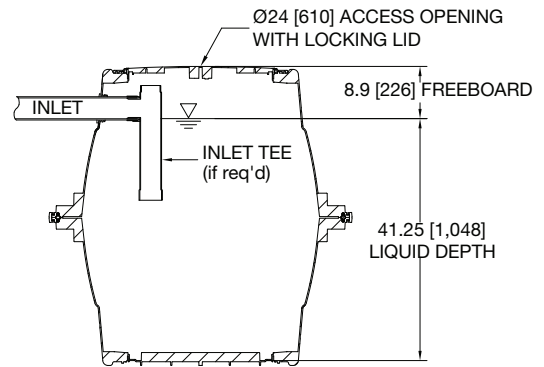

SECTION VIEW

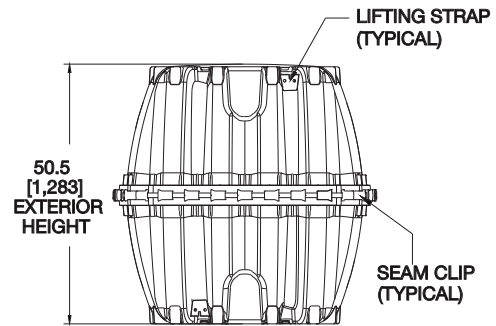

END VIEW

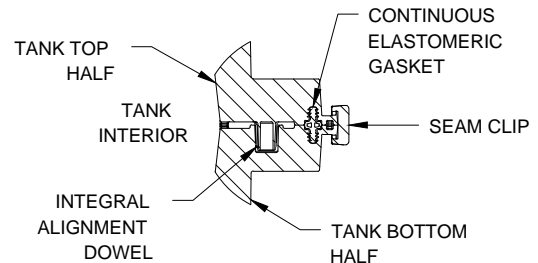

MID-HEIGHT SEAM SECTION



INFILTRATOR
water technologies

4 Business Park Road
P.O. Box 768
Old Saybrook, CT 06475
860-577-7000 • Fax 860-577-7001
1-800-221-4436
www.infiltratorwater.com
info@infiltratorwater.com

For U.S. Patents information visit www.infiltratorwater.com/patents. Other patents pending. Infiltrator, Quick4 and EZflow are registered trademarks of Infiltrator Water Technologies. Infiltrator Water Technologies is a wholly-owned subsidiary of Advanced Drainage Systems, Inc. (ADS).

© 2024 Infiltrator Water Technologies, LLC. Not responsible for any typographic errors. Printed in U.S.A.

IM03 0124

Contact Infiltrator Water Technologies' Technical Services Department for assistance at 1-800-221-4436