



The Infiltrator IM-540 is a lightweight strong and durable septic/pump tank. This watertight tank design is offered with Infiltrator's line of custom-fit risers and heavy-duty lids. Infiltrator injection molded tanks provide a revolutionary improvement in plastic tank design, offering long-term exceptional strength and watertightness.

Features & Benefits

- Strong injection molded polypropylene construction
- Lightweight plastic construction and inboard lifting lugs allow for easy delivery and handling
- Integral heavy-duty green lids that interconnect with TW™ risers and pipe riser solutions
- Structurally reinforced access ports eliminate distortion during installation and pump-outs
- Reinforced structural ribbing offers additional strength
- Can be installed with 6" to 48" of cover
- Can be pumped dry during pump-outs
- Suitable for use as a pump tank or rainwater (non-potable) tank
- No special installation, backfill or water filling procedures are required
- No special water filling requirements are necessary
- The tank may be backfilled with suitable native soil. See installation instructions for guidance.

TANK CUTAWAY

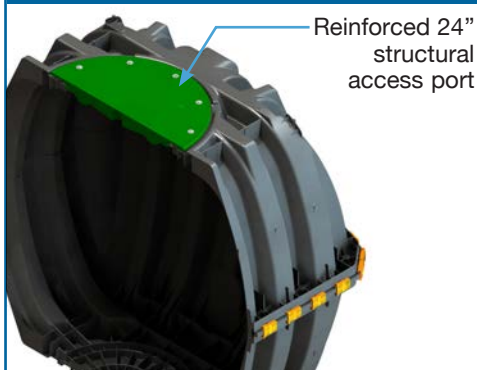

MID-SEAM CUTAWAY

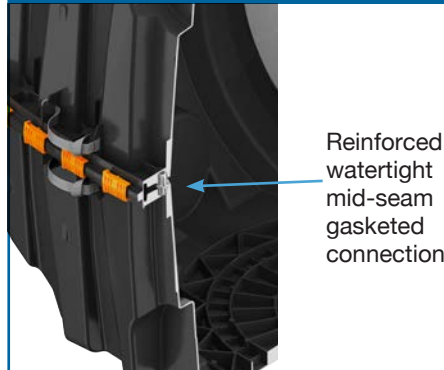

RISER CUTAWAY

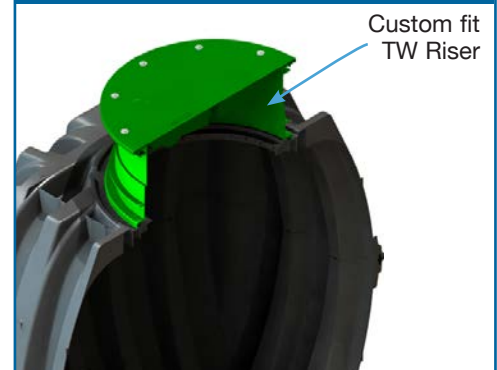

IM-540 General Specifications and Illustrations

The IM-540 is an injection molded two piece mid-seam plastic tank. The IM-540 injection molded plastic design allows for a mid-seam joint that has precise dimensions for accepting an engineered EPDM gasket. Infiltrator's gasket design utilizes technology from the water industry to deliver proven means of maintaining a watertight seal. The two-piece design is permanently fastened using a series of non-corrosive plastic alignment dowels and locking seam clips. The IM-540 is assembled and sold through a network of certified Infiltrator distributors.

Must be backfilled and installed in accordance with Infiltrator Water Technologies, Infiltrator IM-Series Septic Tank General Installation Instructions and for shallow ground water conditions reference the Infiltrator IM-Series Tank Buoyancy Control Guidance.

Please visit www.infiltratorwater.com/images/pdf/ManualsGuides/TANK01.pdf for the latest information.

IM-540	
Total Capacity	552 gal (2090 L)
Length	64.9" (1648 mm)
Width	61.7" (1567 mm)
Height	54.6" (1387 mm)
Maximum Burial Depth	48" (1219 mm)
Minimum Burial Depth	6" (152 mm)
Maximum Pipe Diameter	4" (100 mm)
Weight	169 lbs (77 kg)

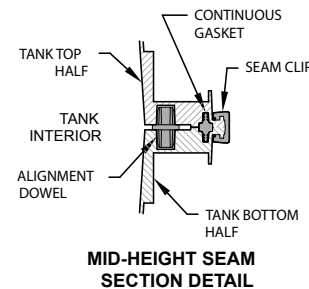
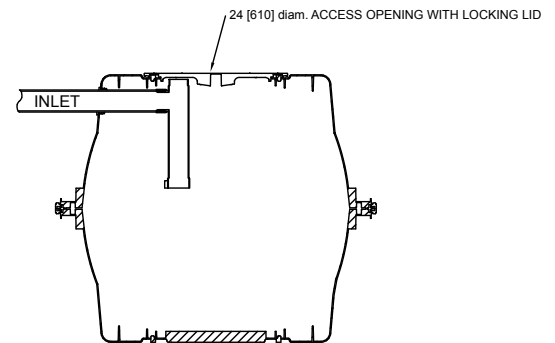
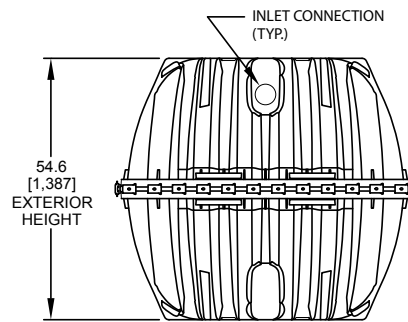
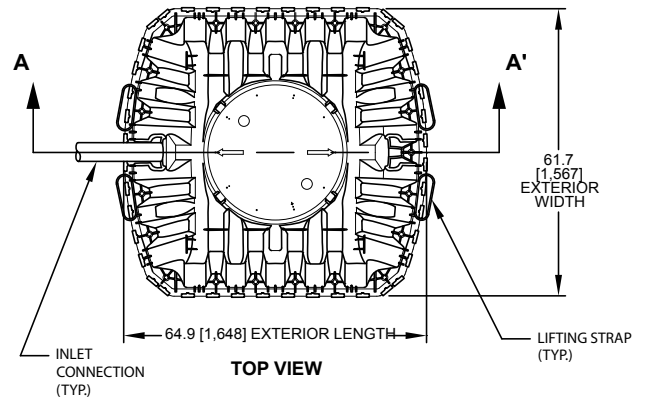

(317) 346-4110
www.drainagesolutionsinc.com



U.S. Patents: 4,759,661; 5,017,041; 5,156,488; 5,336,017; 5,401,116; 5,401,459; 5,511,903; 5,716,163; 5,588,778; 5,839,844 Canadian Patents: 1,329,959; 2,004,564 Other patents pending. Infiltrator, Equalizer, Quick4, and SideWinder are registered trademarks of Infiltrator Water Technologies. Infiltrator is a registered trademark in France. Infiltrator Water Technologies is a registered trademark in Mexico. Contour, MicroLeaching, PolyTuff, ChamberSpacer, MultiPort, PosiLock, QuickCut, QuickPlay, SnapLock and StraightLock are trademarks of Infiltrator Water Technologies. PolyLok is a trademark of PolyLok, Inc. TUF-TITE is a registered trademark of TUF-TITE, INC. Ultra-Rib is a trademark of IPEX Inc.

© 2013 Infiltrator Water Technologies, LLC. All rights reserved. Printed in U.S.A.