

**TOP VIEW**

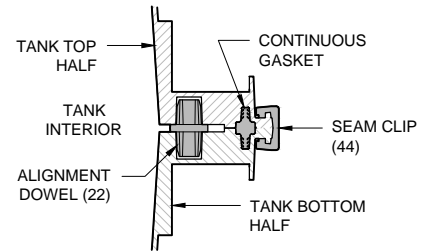

**Ⓢ MID-HEIGHT SEAM SECTION DETAIL**

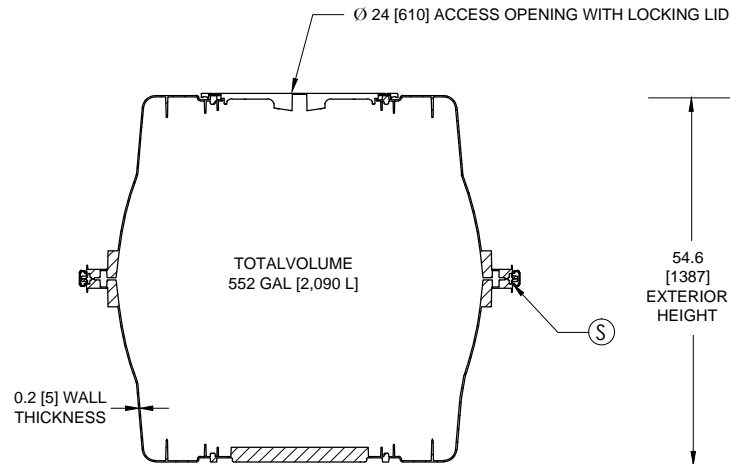

**SECTION A - A'**

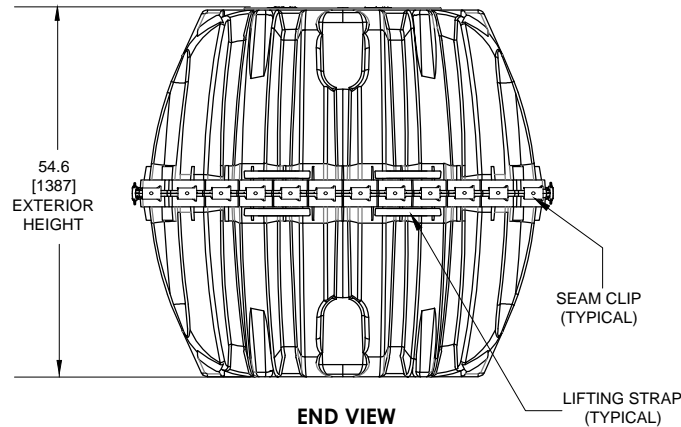

**END VIEW**

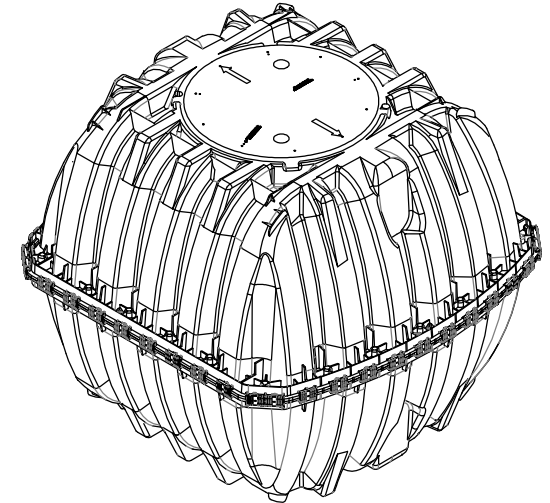

**ISOMETRIC VIEW**

**NOTES:**

1. ALL DRAWING DIMENSIONS IN INCHES [MILLIMETERS] OR AS NOTED.
2. EXTERIOR OF ACCESS DEPTH INCLUDES THE FOLLOWING WARNING IN ENGLISH, FRENCH & SPANISH: "DANGER DO NOT ENTER: POISON GASES."
3. TANK MARKINGS WILL INCLUDE: MANUFACTURER NAME, MODEL NUMBER, LIQUID CAPACITY, DATE OF MANUFACTURE CODE, MAXIMUM BURIAL DEPTH, INLET, AND OUTLET.
4. MAXIMUM BURIAL DEPTH IS 48 in [1219 mm].
5. MINIMUM BURIAL DEPTH IS 6 in [152 mm].
6. TANK IS FOR NON-TRAFFIC APPLICATIONS.
7. NOMINAL WALL THICKNESS IS 0.20 in [5 mm].



**DRAINAGE  
SOLUTIONS, INC**

(317) 346-4110

www.drainagesolutionsinc.com



Infiltrator Systems Inc.  
4 Business Park Rd. Old Saybrook, CT 06475  
(800) 221-4436

**IM-540**  
**Pump/Siphon Tank Configuration**

Drawn by: EMB	Checked by: DJL	Date: 05-30-13
Scale: Not to scale	Drawing: IM-540-VA	Sheet: 1 of 1