

4 ARRAY
scale 1:5

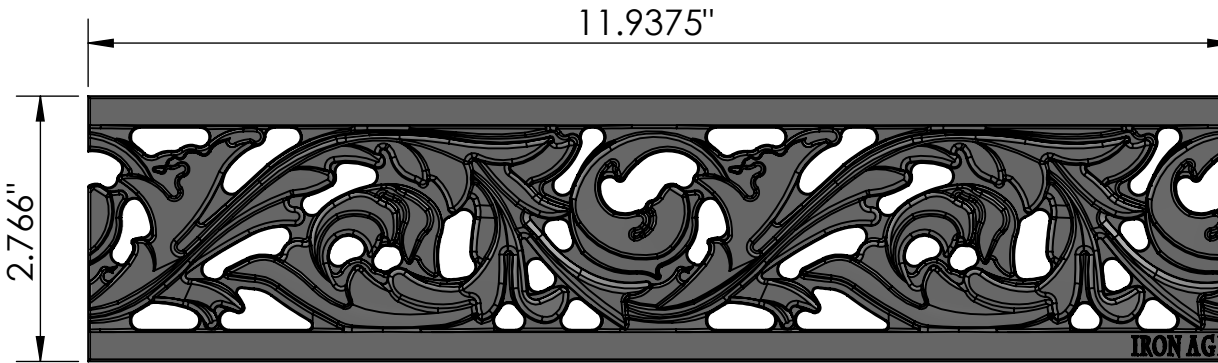

CASTING-ID
scale 1:1

TOP VIEW
scale 1:2



END VIEW
scale 1:2

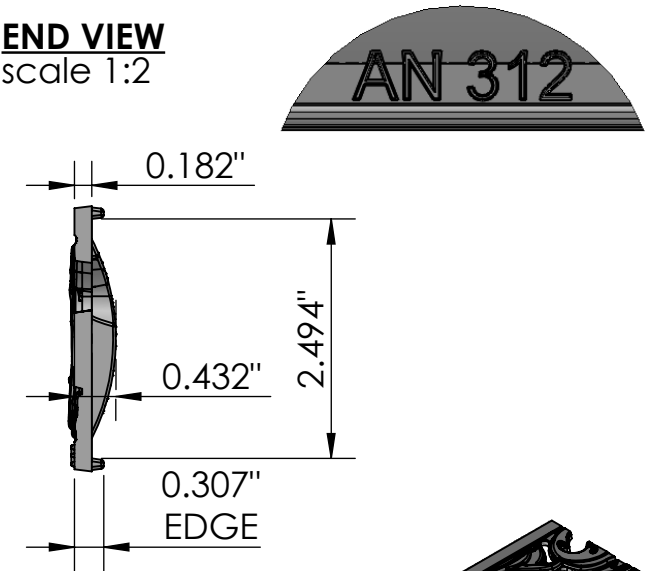

SIDE VIEW
scale 1:2

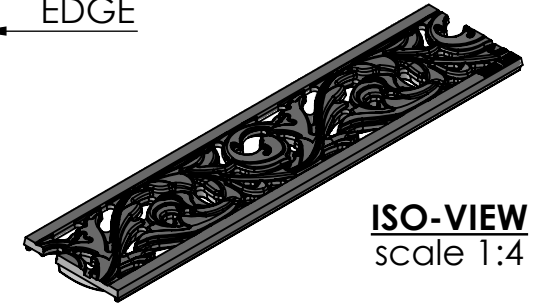

ISO-VIEW
scale 1:4



DRAINAGE SOLUTIONS, INC (317) 346-4110
www.drainagesolutionsinc.com

Acanthus 3" x 12" Trench Grate

NOTES:

1. ADA Compliant: No thru openings greater than 1/2".
2. Ships in pieces: 1
3. Due to casting inconsistencies, all dimensions are nominal.

Made in USA ©2012 Iron Age Designs

 IRON AGE DESIGNS Telephone 206.276.0925 www.ironagegrates.com	Material: Ductile Iron 65-45-12	Weight: 2.00 lbs.	Free Drain Area: 4.93 in/sq., or 14.96 %	By: MS Checked: MS Date: 2-2-21
	Finish: Raw	Edge: 0.307"	Flow Rate: 6.46 GPM, or .014 CuFt./sec.	© Registration: VA 1-970-746 Scale: NTS
	Fits: NDS® NDS® Mini Channel	Product ID: ACN3-12101	Drawing Name: 05_ACT_N_3x12_TrenchGrate_Iron	