

**3 ARRAY**  
scale 1:4

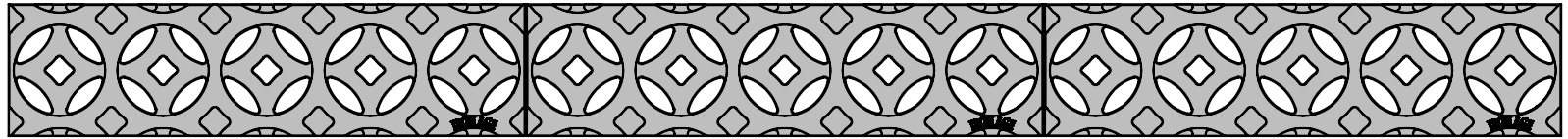

**TOP VIEW**  
scale 1:2

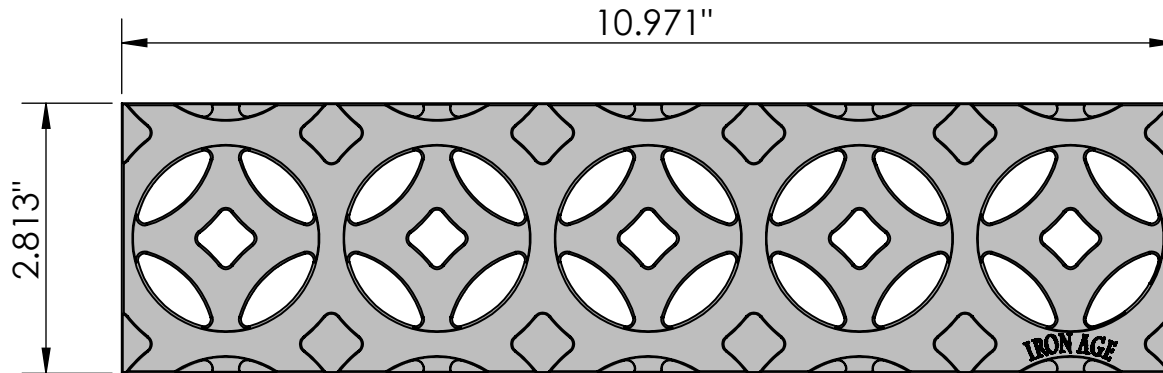

**END View**  
scale 1:2

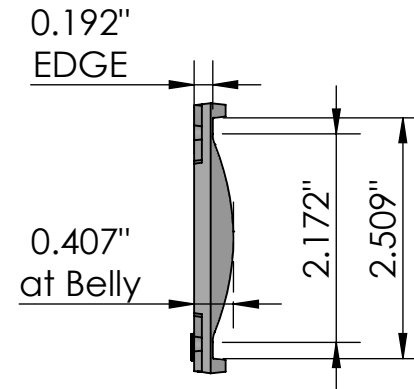

**CASTING-ID**  
scale 1:1

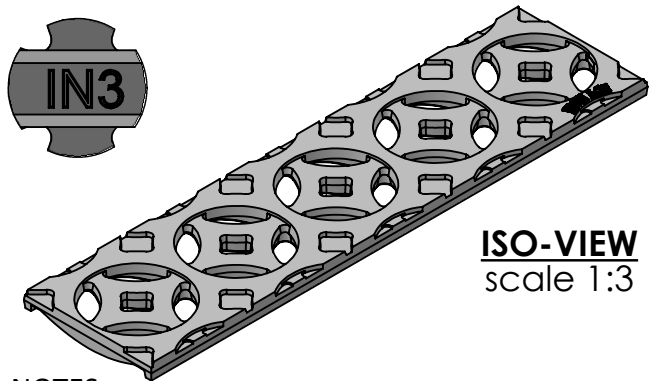

**ISO-VIEW**  
scale 1:3

**SIDE VIEW**  
scale 1:2

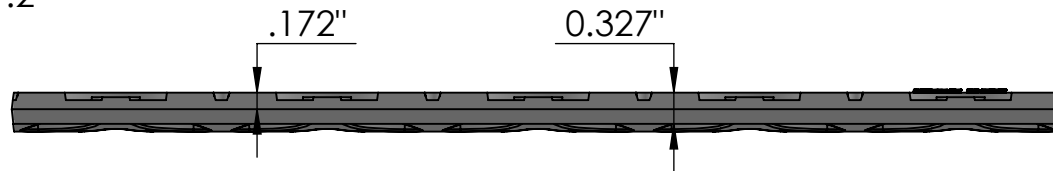

**NOTES:**

1. ADA Compliant: No thru openings greater than 1/2".
2. Ships in pieces: 1
3. Due to casting inconsistencies, all dimensions are nominal.

Made in USA ©2007 Iron Age Designs



**DRAINAGE SOLUTIONS, INC**

(317) 346-4110  
www.drainagesolutionsinc.com

**Interlaken 3" x 11" Trench Grate**

 Telephone 206.276.0925 www.ironagegrates.com	<b>Material:</b> Ductile Iron 65-45-12	<b>Weight:</b> 1.56 lbs.	<b>Free Drain Area:</b> 6.57 in/sq., or 21.30 %	<b>By:</b> MS <b>Checked:</b> MS <b>Date:</b> 8-20-21
	<b>Finish:</b> Raw	<b>Edge:</b> .192"	<b>Flow Rate:</b> 8.61 GPM, or .019 CuFt./sec.	<b>© Registration:</b> VA 2-007-115 <b>Scale:</b> NTS
	<b>Fits:</b> NDS® Mini Channel	<b>Product ID:</b> IN3-11101	<b>Drawing Name:</b> 01_INT_N_3x11_TrenchGrate_Iron	