

# MODEL 405

Commercial Drain Pump

# Liberty Pumps®

A Family and Employee Owned Company



**DRAINAGE**  
SOLUTIONS, INC

(317) 346-4110

[www.drainagesolutionsinc.com](http://www.drainagesolutionsinc.com)

## 1/2 hp 3/8" Solids Handling High-Head High Temperature

Featuring QuickTree® technology for easy switch access!

### Features

- Factory pre-assembled, ready to install
- Fully automatic operation
- Handles fluid temperatures to 180°F (Not designed for use with chemicals)
- Separate access cover for easy switch inspection
- 2" Discharge, inlet, and vent
- Integrally molded rubber gasket for a superior gas-tight seal
- Standard alarm and Wi-Fi alarmed models available

### Applications

- Bar sinks
- Laundry trays
- Multi-compartment utility sinks
- Dehumidifiers
- Dishwashers
- Gray wastewater drainage below gravity lines



**NightEye®**  
Wireless Enabled  
Models Available



innovate. evolve.

# Model 405 & 405HV

## Features

- Factory pre-assembled
- Fully automatic operation
- QuickTree® technology allows quick inspection and removal of float switch without disconnecting the plumbing
- Oil-filled motor with thermal-overload protection
- Corrosion-resistant polyolefin basin with integrally molded rubber gasket for a superior gas-tight seal
- Maintenance-free, permanently lubricated sealed bearings
- 10' Power cord with ground plug
- 3/8" Solids handling
- 1/2 hp

## Maximum Fluid Temperature

180°F  
Not intended for use with chemicals.

## Applications

- Laundry Trays
- Commercial Sinks
- Bar Sinks
- Dishwashers
- Dehumidifiers
- Wherever gray wastewater drainage is needed below gravity lines

Specifically designed for higher head applications such as commercial and industrial buildings.

MODELS	HP	VOLTS	AMPS	DISCHARGE, INLET & VENT	ALARM
405	1/2	115	7.3	2"	No
405/A	1/2	115	7.3	2"	Standard Alarm
405/A-EYE	1/2	115	7.3	2"	NightEye® Wireless
405HV	1/2	230	3.5	2"	No

Alarmed models come with factory mounted alarm float in system. No assembly required. See Alarm literature for ALM-2 standard alarm or NightEye® Wi-Fi alarm for complete alarm specifications.

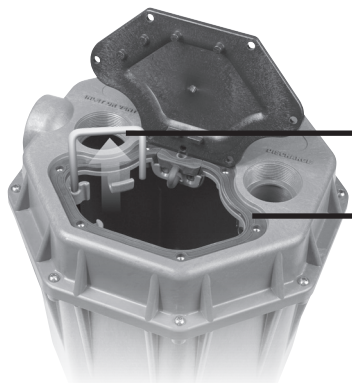

QuickTree® technology allows easy removal of float switch without disconnecting plumbing or pulling the pump

Heavy-duty integrally molded rubber gasket provides a superior seal. Meets 10' stack test requirements.

## Dimensional Data

**Weight:** 16 lbs  
**Major Height:** 14-1/8"  
**Major Width:** 13-3/4"  
**Inlet Height** (from bottom of basin): 12-5/8"  
**Total Capacity:** 5.5 gallons  
**Inlet Size:** 2"  
**Discharge Size:** 2"  
**Vent Size:** 2"

## Performance Curve

60 Hz 3450 RPM

