

Installation Manual

5488000A

Model 406 Drain Pump



DRAINAGE
SOLUTIONS, INC

(317) 346-4110

www.drainagesolutionsinc.com

Features

- Appliance-style design
- Compact size
- Bottom inlets accommodate shower plumbing
- Maximum fluid temp 140°F/60°C
- Integral discharge check valve
- Integral side inlet check valve
- Discharge size options via single adapter
- Serviceable float switch and pump cartridge



NOTICE

Installer: Manual must remain with owner/operator.

Prior to installation, record information from pump nameplate for future reference:

7000 Apple Tree Avenue
Bergen, NY 14416
ph: 1-800-543-2550
fax: 1-585-494-1839
www.LibertyPumps.com

Keep this manual handy for future reference.
For replacement manual, visit LibertyPumps.com,
or contact Liberty Pumps at 1-800-543-2550.
Retain dated sales receipt for warranty.

Model: _____

Serial: _____





Mfg Date: _____

Install Date: _____

Contents

Safety Precautions	2 EN
Model Specifications	3 EN
General Information	3 EN
Preparation	5 EN
Installation	5 EN
Test System	6 EN
Operation	6 EN
Maintenance and Troubleshooting	6 EN
Warranty	8 EN

Safety Guidelines

	This safety alert symbol is used in the manual and on the pump to alert of potential risk for serious injury or death.
	This safety alert symbol identifies risk of electric shock . It is accompanied with an instruction intended to minimize potential risk of electric shock.
	This safety alert symbol identifies risk of fire . It is accompanied with an instruction intended to minimize potential risk of fire.
	This safety alert symbol identifies risk of serious injury or death . It is accompanied with an instruction intended to minimize potential risk of injury or death.
⚠ DANGER	Warns of hazards which if not avoided will result in serious injury or death.
⚠ WARNING	Warns of hazards which if not avoided could result in serious injury or death.
⚠ CAUTION	Warns of hazards which if not avoided could result in minor or moderate injury.
NOTICE	Signals an important instruction related to the pump. Failure to follow these instructions could result in pump failure or property damage.

⚠ WARNING Read every supplied manual before using pump system. Follow all the safety instructions in manual(s) and on the pump. Failure to do so could result in serious injury or death.

Safety Precautions

⚠ WARNING RISK OF ELECTRIC SHOCK

- Accidental contact with electrically live parts, items, fluid, or water can cause serious injury or death.
- Always disconnect the pump from power source before attempting to service the pump. Fatal electrical shock could occur.

- All installation and maintenance of pumps, controls, protection devices, and general wiring shall be done by qualified personnel.
- The pump shall be plugged into a properly fused electrical outlet with a ground fault circuit interrupter (GFCI) that conforms to current National Electric Code (NEC) and all applicable local codes. All wiring must be performed by qualified personnel.
- All electrical and safety practices shall be in accordance with the National Electrical Code®, the Occupational Safety and Health Administration, or applicable local codes and ordinances.
- Pump shall be properly grounded using its supplied grounding conductor. Do not bypass grounding wires or remove ground prong from attachment plugs. Failure to properly ground the pump system can cause all metal portions of the pump and its surroundings to become energized.
- Do not handle or unplug the pump with wet hands, when standing on damp surface, or in water unless wearing Personal Protective Equipment.
- Always wear dielectric rubber boots and other applicable Personal Protective Equipment (PPE) when water is on the floor and an energized pump system must be serviced, as submerged electrical connections can energize the water. Do not enter the water if the water level is higher than the PPE protection or if the PPE is not watertight.
- Do not lift or carry the pump by its power cord. This will damage the power cord, and could expose the electrically live wires inside the power cord.
- The electrical power supply shall be located within the length limitations of the pump power cord, and for below grade installations it shall be at least 4 ft (1.22 m) above floor level.
- Do not use this product in applications where human contact with the pumped fluid is common (such as swimming pools, fountains, marine areas, etc.).
- Protect the power and control cords from the environment. Unprotected power and control (switch) cords can allow water to wick through ends into pump or switch housings, causing surroundings to become energized.

⚠ WARNING RISK OF FIRE

- Do not use an extension cord to power the product. Extension cords can overload both the product and extension cord supply wires. Overloaded wires will get very hot and can catch on fire.
- This product requires a separate, properly fused and grounded branch circuit, sized for the voltage and amperage requirements of the pump, as noted on the nameplate. Overloaded branch circuit wires will get very hot and can catch on fire. When used, electrical outlets shall be simplex of the appropriate rating.
- Do not use this product with or near flammable or explosive fluids such as gasoline, fuel oil, kerosene, etc. If rotating elements inside pump strike any foreign object, sparks may occur. Sparks could ignite flammable liquids.

- These pumps are not to be installed in locations classified as hazardous in accordance with the National Electric Code®, ANSI/NFPA 70.

⚠ WARNING  **RISK OF SERIOUS INJURY OR DEATH**

- Do not modify the pump/pump system in any way. Modifications may affect seals, change the electrical loading of the pump, or damage the pump and its components.
- All pump/pump system installations shall be in compliance with all applicable Federal, State, and Local codes and ordinances.
- Do not allow children to play with the pump system.
- Do not allow any person who is unqualified to have contact with this pump system. Any person who is unaware of the dangers of this pump system, or has not read this manual, can easily be injured by the pump system.
- Do not remove any tags or labels from the pump or its cord.
- Keep clear of suction and discharge openings. To prevent injury, never insert fingers into pump while it is connected to a power source.
- Do not use this product with flammable, explosive, or corrosive fluids. Do not use in a flammable and/or explosive atmosphere as serious injury or death could result.
- This product contains chemicals known to the State of California to cause cancer and birth defects or other reproductive harm. www.p65warnings.ca.gov.

⚠ CAUTION

- ◆ This pump has been evaluated for use with water only.

NOTICE

- ◆ Do not use pumps with fluid over 140°F (60°C). Operating the pump in fluid above this temperature can overheat the pump, resulting in pump failure.
- ◆ Do not dispose of materials such as paint thinner or other chemicals down drains. Doing so could chemically attack and damage pump system components and cause product malfunction or failure.
- ◆ Do not use pump system with mud, sand, cement, hydrocarbons, grease, or chemicals. Pump and system components can be damaged from these items causing product malfunction or failure. Additionally, flooding can occur if these items jam the impeller or piping.
- ◆ Do not run dry.
- ◆ Do not use an air admittance valve or a mechanical spring-loaded venting device, as these devices are one-way valves. The air pressure in and outside the pump unit must be equal and a "cheater" vent will obstruct the airflow in one direction and prevent proper function.
- ◆ Use of a lint trap on a washing machine drain is recommended for proper check valve performance.

Model Specifications

For complete listing of models and their specifications, refer to <http://www.LibertyPumps.com/About/Engineering-Specs>. Pump nameplate provides a record of specific pump information.

General Information

The sleek new Model 406 is an appliance grade product with a refined look and feel. This unit can handle an indirect connection (via a laundry sink) to a washing machine, indirect connection (through a drain trap) to a dishwasher, and a direct connection to a number of other fixtures including sinks and showers. There are (3) inlet locations (with provisions for 2 inlets included), (1) vent, and (1) stepped discharge adapter with integral check valve that can adapt to 1", 1-1/4", and 1-1/2" pipe sizes. Additionally, the 406 features an integral float switch/wiring harness assembly, a pump power "cartridge" that can be easily removed for servicing, and a bottom/side inlet adapter with a pre-installed check valve.

Features

- Ability to remove both the float switch and pump "cartridge" through the access area, without removing the main chassis
- Three discharge options [1-1/2", 1-1/4", 1"] accomplished with a single stepped discharge adapter
- Integral side inlet check valve adapter can be used on either side of tank

Connection Kit Parts List

1. (1) Discharge adapter [1-1/2", 1-1/4", 1"]
2. (3) Inlet and vent adapters
3. (1) Side inlet coupler
4. (7) Stainless steel clamps
5. (2) Top plug gaskets (replacement parts)

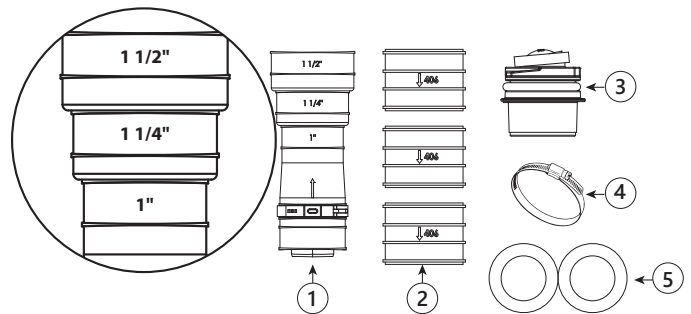

Additional connection kit #K001929 is available from Liberty Pumps.

Dimensional Data

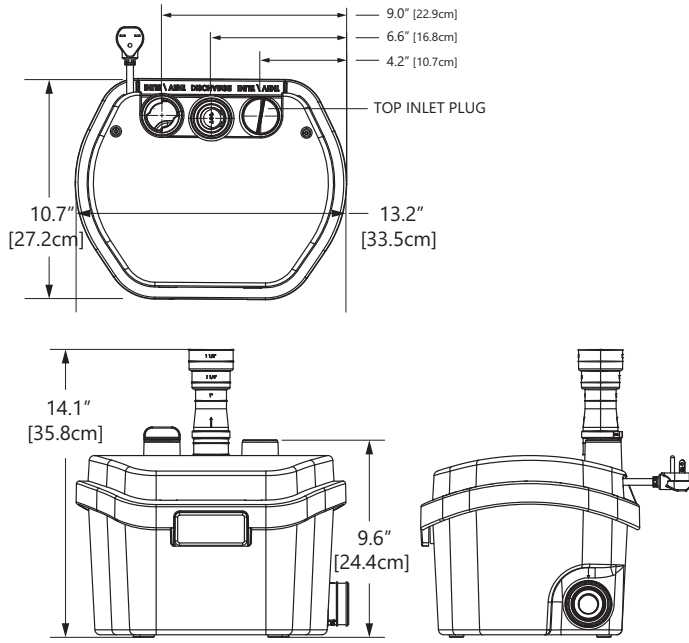

Typical Installations



Performance Curve

For proper performance, tank inflow cannot exceed pump discharge capacity at the installed head level. For technical assistance, consult the factory at 1-800-543-2550.

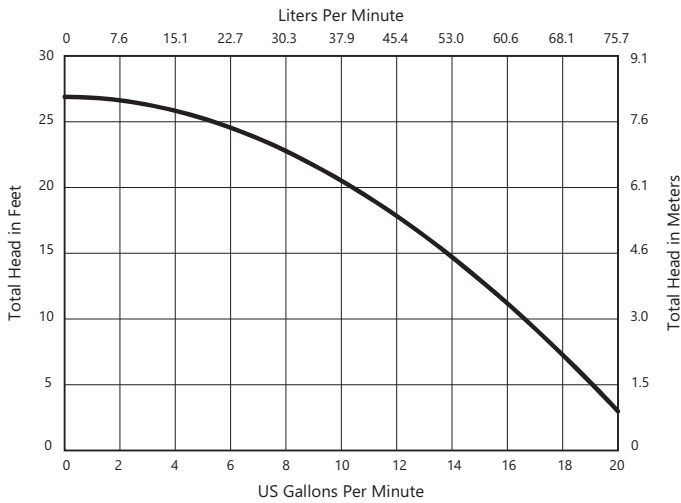

Preparation

Before installing the Model 406 automatic drain pump, take the following into consideration:

Layout

The layout should be considered prior to installation. The power source (GFCI receptacle) shall be within range of the unit's 9' power cord. The GFCI receptacle shall be a minimum of 40" away (in a straight line) from a shower or bathtub. For basement installation, the receptacle shall be 48" from the floor.

Power Cord

The power cord can be configured to exit the unit on either the left or right side, with any extra cord coiled and tucked away under the decorative cover.

Easy Access

The unit should be accessible in the event of required maintenance. During installation, a full port ball valve should be installed at the base of the discharge to allow easy service of the unit.

Pipework

All pipework shall be copper, PVC, or CPVC. Do not use flexible or semi-flexible pipe. All sanitary pipework shall be supported in accordance with the pipe manufacturer's recommendations.

Discharge

Never discharge directly into an open drain, fixture, manhole or rainwater drainpipe. It is illegal as it constitutes a health hazard. Only direct connections into sanitary waste systems shall be acceptable.

Bathtub/Shower

If a bathtub or shower is connected, a base will have to be constructed. This base should be made out of a 2" x 6" (minimum) or 2" x 8" (recommended) on edge to allow for the installation of a P-trap and the required 1/4" per foot gravity flow toward the unit. Allowing at least 6–8" fall ensures proper drainage and prevents any backflow.

Vertical Lift

If vertical lift is required, this shall precede the horizontal pipe run. Once the horizontal run is started, do not change directions in a vertical manner.

Bends

Only long sweeping bends shall be used. Do not use short elbows (90° elbows). If sweeping 90° elbows are not available, use two 45° elbows to make a 90° turn.

Inlet

All inlet pipework shall have a positive gravity fall of at least 1/4" per foot.

Discharge Piping

All discharge piping from the unit shall run either directly vertical or in a horizontal plane (with a minimum 1/4" per foot drop) to the point of discharge. Pipework shall not be installed with a diagonal upward slope from the unit to the point of discharge. Long downward pitched runs of discharge piping, or piping where the point of discharge is at a lower elevation than the unit, shall be designed to prevent siphoning from the tank.

Trap

A trap shall be used between the fixture and pump; a flange type is recommended.

Freezing

Ensure all pipework susceptible to freezing is adequately insulated or heated. In unheated buildings, the unit and piping shall be properly winterized. Use plumbing antifreeze or drain completely.

Installation

NOTICE

- ◆ All cut pipe ends *must* be clean and deburred to ensure a good connection.

Top Inlet

Either side top port (center is discharge) can be used as an inlet. Connect the fixture (i.e., laundry tub, bar sink, washing machine (indirectly via laundry tub)) to the unit using a flexible coupling/clamp.

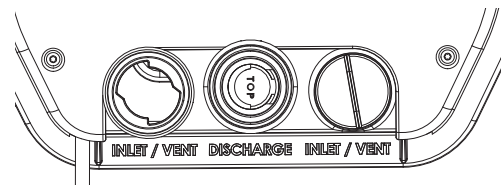

Note: Use of a lint trap on a washing machine drain is recommended for proper check valve performance.

If the top inlet is not being used, secure the plug to the inlet.

Side Inlet

The pump has two side inlets on either side to accommodate sanitary fixtures. To connect to the side inlets, use provided rubber coupling/clamps. Only one check valve is included for the side inlet coupling. If both inlets are being used, another check valve is required.

Note: The side inlet check valve does not seat flush into the connector. The check valve is tipped; this is the correct installation orientation.



If either side inlet is not being used, secure the plug to the inlet.

Vent

NOTICE

- ◆ Do not use an air admittance valve or a mechanical spring-loaded venting device.

Either side top port (center is discharge) can be used as a vent. Use a flexible coupling/ clamp to connect the vent to the PVC pipe for the vent connection.

The vent pipe should have a union to facilitate removal and shall be connected directly to a building or house vent.

Discharge

The wastewater being evacuated from this unit shall be discharged using a 1", 1.25" or 1.5" diameter copper or plastic (PVC, CPVC) pipe. This pump is designed to handle 1/8" particles. The discharge pipe shall be connected to a drain line or sewer line using an approved "Y" fitting designed for this purpose.

Install a union just above the unit to facilitate removal when needed for cleaning or service.

Test System

1. Plug the cord into a properly grounded GFCI receptacle.
2. Allow water to fill the basin.
3. Check all plumbing for leaks as the basin fills.
4. Verify that the pump starts and stops.
5. Check the discharge line for leaks as the pump empties the basin.
6. Repeat Steps 2 through 5 as necessary to ensure proper operation.
7. If problems persist, refer to **Troubleshooting**.

Operation

Unit will turn on when the liquid level has risen to activate the float switch. No user interaction is required. Likewise, the unit will turn off when the liquid is removed to such a level as the pump is no longer required.

Maintenance and Troubleshooting

⚠ WARNING ⚡ RISK OF ELECTRIC SHOCK

- Always disconnect the pump from power source before attempting to service the pump. Fatal electrical shock could occur.

Maintenance

If used infrequently, test the unit **monthly** to verify proper operation.

Routine maintenance is not required on the pump itself, but associated connections may require occasional attention.

Lint and foreign objects should be removed from the trap periodically. The check valve on the discharge should also be checked for freedom of operation at the same time.

Foam gaskets under top plug(s) may wear/tear and need replacement. Two gaskets are included in the connection kit. Replace as needed.

Replacement connection kit #K001929 is available from Liberty Pumps.

Troubleshooting

In the event service needs to be done on the unit, the pump and float switch are easily accessible under the decorative cover.

For wet end serviceability, remove the pump cartridge by a 1/4 turn. The pump cartridge is clearly marked with LOCK and UNLOCK arrows.

Note: the pump cartridge turns *clockwise to unlock*. This is so that when the pump turns on, the kick direction has a positive stop and won't loosen the cartridge over time.

The float switch is accessed for cleaning and/or replacement by removing four screws.

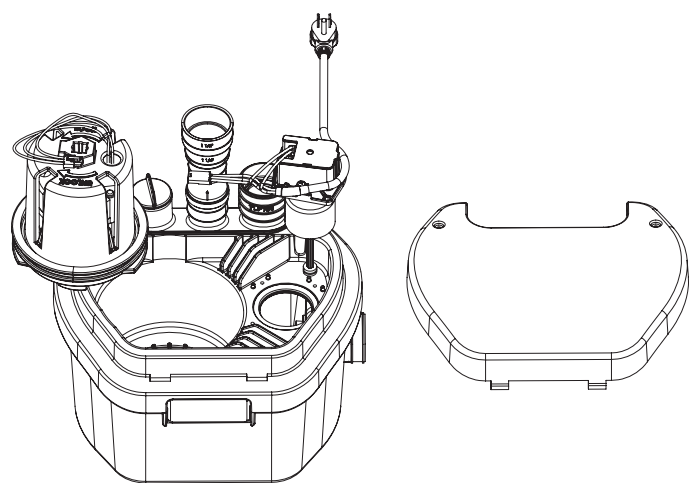
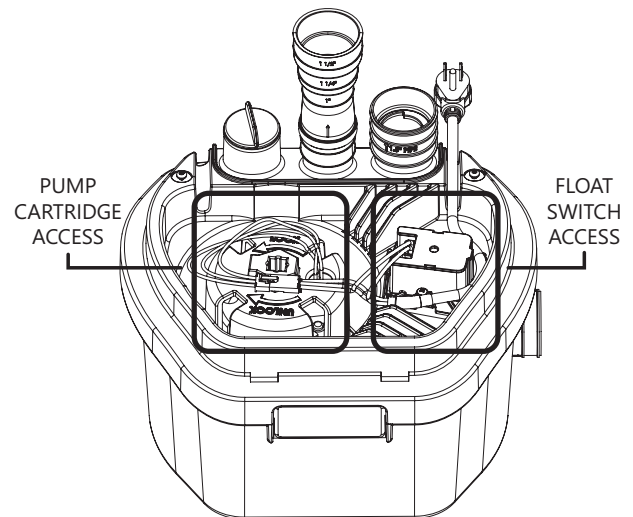

Table 1. Troubleshooting Matrix

Problem	Possible Cause	Corrective Action
Pump does not start.	Tripped circuit breaker, tripped GFCI, or other interruption of power.	Check that the unit is securely plugged in, investigate power interruption.
	Defective float switch or build-up on tank wall restricting free movement of float switch.	Remove access cover and check that float switch is free to move. If build-up restricts float switch, clean and reinstall. If defective, replace switch.
	Plugged vent, or quick-vent in use.	Verify that an unrestricted vent at least 1-1/4" in diameter is in use. <i>Quick-vents shall not be used.</i>
	Thermal overload has interrupted power.	Wait for thermal overload to disengage (about 20 minutes).
Pump short-cycles.	Plugged vent, or quick-vent in use.	Verify that an unrestricted vent at least 1-1/4" in diameter is in use. <i>Quick-vents shall not be used.</i>
	Defective float switch or build-up on tank wall restricting free movement of float switch.	Remove access cover and check that float switch is free to move. If build-up restricts float switch, clean and reinstall. If defective, replace float switch.
	Check valve stuck open or leaking.	Remove check valve and examine for freedom of operation and proper installation.
Pump runs or hums but does not pump.	Discharge line blocked or restricted.	Check discharge line for foreign material, including ice if discharge line passes through or into cold areas.
	Check valve stuck closed.	Remove check valve(s) and examine for freedom of operation and proper installation.
	Total head (lift height) is beyond pump's capability.	Route piping to a lower level. If not possible, a larger pump may be required. Consult Liberty Pumps.
	Obstructed impeller or volute.	Remove obstruction.
Pump runs but does not turn off.	Defective float switch or build-up on tank wall restricting free movement of float switch.	Remove access cover and check that float switch is free to move. If build-up restricts float switch, clean and reinstall. If defective, replace float switch.
Pump runs periodically when fixtures are not in use.	Check valve stuck open or leaking.	Remove check valve and examine for freedom of operation and proper installation. Clear any debris / contamination.
	Fixtures leaking.	Repair fixtures as required to eliminate leakage.
Pump runs normally, but the water drains slowly.	Discharge is blocked or restricted.	Check discharge line for restrictions.
	Check valve stuck open or leaking.	Remove check valve and examine for freedom of operation and proper installation.
	Plugged vent, or quick-vent in use.	Verify that an unrestricted vent at least 1-1/4" in diameter is in use. <i>Quick-vents shall not be used.</i>
Pump operates noisily.	Piping attachments to building are too rigid.	Replace a portion of discharge line with rubber hose or connector.
	Foreign objects in the impeller cavity.	Clean impeller cavity.
Water backs up into sanitary fixture.	Side inlet requires at least 6" fall.	Make sure that the gravity fall is at least 1/4" per foot into the pump from the sanitary fixtures.
	Faulty inlet check valve.	Inspect inlet check valve.
	Vent is blocked, restricted, or quick-vent in use.	Check vent line for obstructions or restrictions. Quick-vents shall not be used.
	Discharge is blocked or restricted.	Check discharge line for obstructions or restrictions.

Table 1. Troubleshooting Matrix (continued)

Problem	Possible Cause	Corrective Action
Sanitary fixture making gurgling noise.	Improper venting.	Check vent line for obstructions or restrictions.
Water or soap suds come out of vent pipe.	Vent pipe is too short or too small in diameter.	Verify that an unrestricted vent at least 1-1/4" in diameter is in use. <i>Quick-vents shall not be used.</i>
	Rate of inflow exceeds pump output.	Use valve on the inlet to reduce rate of inflow.

Warranty

Liberty Pumps Wholesale Products Limited Warranty

Liberty Pumps, Inc. warrants that Liberty Pumps wholesale products are free from all factory defects in material and workmanship for a period of three (3) years from the date of purchase (excluding* batteries and "Commercial Series" models). The date of purchase shall be determined by a dated sales receipt noting the model and serial number of the pump. The dated sales receipt must accompany the returned pump if the date of return is more than three years from the date of manufacture noted on the pump nameplate.

The manufacturer's sole obligation under this Warranty shall be limited to the repair or replacement of any parts found by the manufacturer to be defective, provided the part or assembly is returned freight prepaid to the manufacturer or its authorized service center, and provided that none of the following warranty-voiding characteristics are evident:

The manufacturer shall not be liable under this Warranty if the product has not been properly installed, operated, or maintained per manufacturer instructions; if it has been disassembled, modified, abused, or tampered with; if the electrical cord has been cut, damaged, or spliced; if the pump discharge has been reduced in size; if the pump has been used in water temperatures above the advertised rating; if the pump has been used in water containing sand, lime, cement, gravel, or other abrasives; if the product has been used to pump chemicals, grease, or hydrocarbons; if a non-submersible motor has been subjected to moisture; or if the label bearing the model and serial number has been removed.

Liberty Pumps, Inc. shall not be liable for any loss, damage, or expenses resulting from installation or use of its products, or for indirect, incidental, and consequential damages, including costs of removal, reinstallation or transportation.

There is no other express warranty. All implied warranties, including those of merchantability and fitness for a particular purpose, are limited to three years from the date of purchase. This Warranty contains the exclusive remedy of the purchaser, and, where permitted, liability for consequential or incidental damages under any and all warranties are excluded.

*Liberty Pumps, Inc. warrants StormCell batteries for 1 year from date of purchase, and warrants that pumps of its Commercial Series are free from all factory defects in material and workmanship for a period of 18 months from the date of installation or 24 months from the date of manufacture, whichever occurs first, and provided that such products are used in compliance with their intended applications as set forth in the technical specifications and manuals.



7000 Apple Tree Avenue
 Bergen, NY 14416
 ph: 1-800-543-2550
 fax: 1-585-494-1839
 www.LibertyPumps.com