

# MODEL 406

Compact Drain Pump

# Liberty Pumps®

A Family and Employee Owned Company



(317) 346-4110

[www.drainagesolutionsinc.com](http://www.drainagesolutionsinc.com)

**1/6 hp**

**1/8" Solids Handling**

## Features

- Factory pre-assembled, ready to install
- Quiet automatic operation
- Short profile design for compact areas – only 10" tall (base to top inlet flange)
- Float switch and pump serviceability via access cover
- Wet-end serviceability via removable pump "cartridge" – simple, 1/4 turn removal
- Rubber gasket for a superior gas-tight seal
- Floor-level side inlets, with integral check valve and couplings included for convenient plumbing
- Stepped discharge adapter – 1", 1.25", 1.5", with integral check valve



Patent: See  
[www.LibertyPumps.com/patents](http://www.LibertyPumps.com/patents)



## Applications

- Bar sinks
- Laundry trays
- Dehumidifiers
- Utility sinks
- Gray wastewater drainage below gravity lines
- Showers



with US and global parts



innovate. evolve.

# Model 406

## Features

- Compact design for tight areas and in cabinets
- Factory pre-assembled
- Fully automatic operation
- Wet-end serviceability with easy to remove motor cartridge
- Integral check valve at bottom inlet connections
- Rubber gaskets for a superior gas-tight seal
- Float switch can be accessed and serviced without disconnecting piping
- Air-cooled motor with thermal-overload protection
- 9', 3-wire power cord with grounded plug
- Corrosion-resistant ABS basin with molded-in connections
- Maintenance free, permanently lubricated sealed bearings
- 1/8" Solids handling

## Maximum Fluid Temperature

104°F (40°C) continuous duty  
 140°F (60°C) intermittent duty (10 seconds on/5 seconds off)

## Motor Specifications

1/6 hp  
 Air-cooled, Thermally Protected

## Dimensional Data

**Weight:** 13.5 lbs  
**Major Height:** 14.1"  
**Major Width:** 13.2"

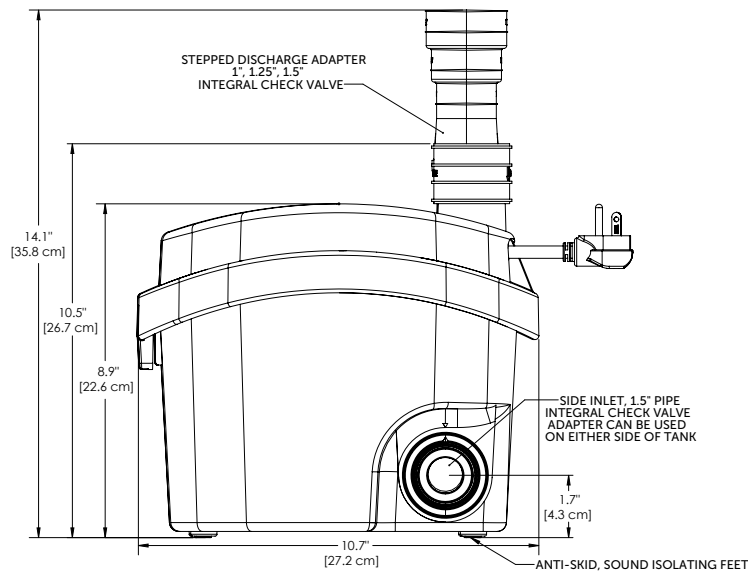

## Included Connection Kit

- 1 Stepped discharge adapter – 1", 1.25", 1.5", with integral check valve
- 1 Side inlet coupling (1.5") with integral check valve
- 1 Top vent coupling (1.5")
- 1 Top inlet coupling (1.5")
- 2 Pre-installed side inlet plugs
- 1 Pre-installed top inlet plug
- 7 Stainless-steel clamps

## Performance Curve

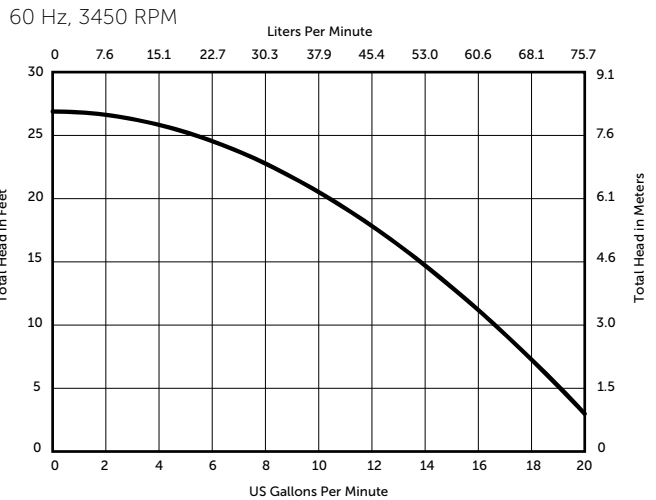

For proper performance, tank inflow cannot exceed pump discharge capacity at the installed head level.  
 For technical assistance, consult the factory at 1-800-543-2550.

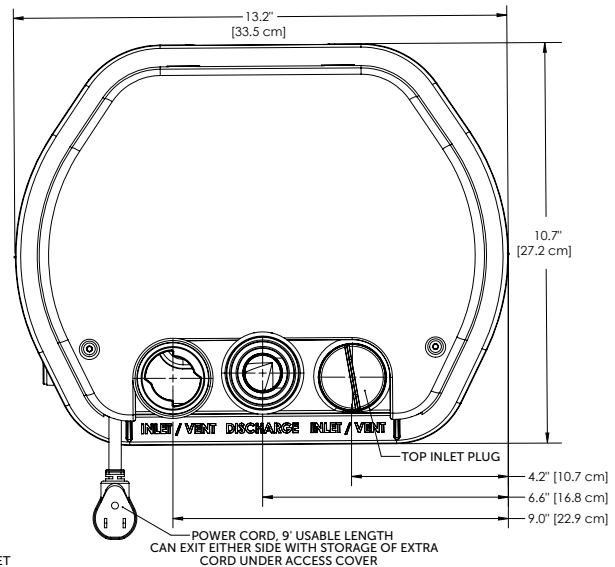

## Models and Specifications

MODEL	HP	AMPS	VOLTS	FREQUENCY	INLET CONNECTIONS	INTEGRAL CHECK VALVE
406	1/6	1.7	115	60 Hz	1.5"	One on discharge One on side inlet
406HV	1/6	1.0	200/230	60 Hz	1.5"	One on discharge One on side inlet

406 Models are CSA Certified to the UPC, IPC, and NPC requirements of ASME A112.3.4 / CSA B45.9

Specifications subject to change without notice.

Copyright © Liberty Pumps, Inc. 2021 All rights reserved. LLIT006794-R08/21

Liberty Pumps - 7000 Apple Tree Avenue - Bergen, New York 14416  
 Phone 800-543-2550 - Fax 585-494-1839 - www.LibertyPumps.com