



DRAINAGE SOLUTIONS, INC

(317) 346-4110
www.drainagesolutionsinc.com

Liberty Pumps®

Pump System Specifications

ELV Auto-Valve Series with Simplex OilTector® Control

ELV280-VS/VST

ELV290-VS/VST

ELVFL63-VS/VST

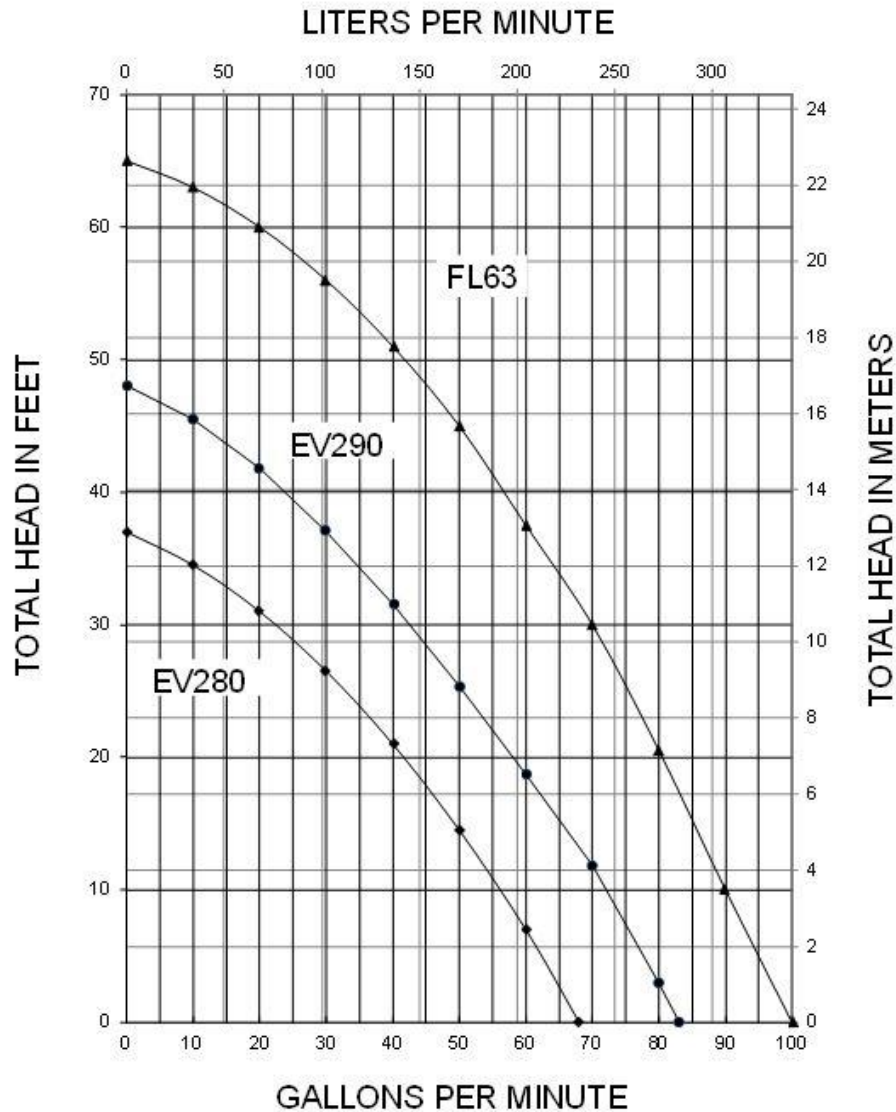
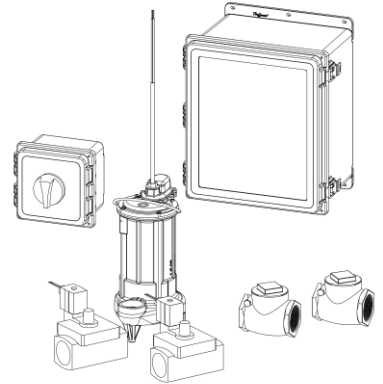

Auto-Valve Series: General Arrangement

NOTES:

STANDARD EQUIPMENT INCLUDES:

- (1) SUMP PUMP
- (2) 2" SOLENOID VALVES
- (2) CHECK VALVES
- (1) REDUCER COUPLING, 1-1/2" X 2" (280 & 290 PUMPS ONLY)
- (1) WATER LEVEL SENSOR W/HIGH OIL SWITCH
- (1) CONTROL PANEL
- (1) JUNCTION BOX W/DISCONNECTS
- (1) HIGH OIL FLOAT
- (1) REMOTE ALARM

OPTIONAL EQUIPMENT

- (1) 59 GALLON OIL STORAGE TANK

PIPE, PIPE FITTINGS, AND NECESSARY INSTALLATION HARDWARE ARE NOT INCLUDED AND SHALL BE SUPPLIED BY OTHERS UNLESS OTHERWISE NOTED.

INSTALLATION OF PUMPS, PIPE, AND FITTINGS SHALL BE EXECUTED BY A LICENSED PROFESSIONAL ACCORDING TO ALL APPLICABLE CODES AND INSTALLATION GUIDELINES.

ALL NECESSARY ELECTRICAL WIRING AND CONNECTIONS SHALL BE EXECUTED BY A LICENSED PROFESSIONAL ACCORDING TO ALL APPLICABLE CODES AND INSTALLATION GUIDELINES.

OIL STORAGE TANK SHALL BE SIZED SUCH THAT IT CAN HOLD UP TO 2 TIMES THE CAPACITY OF OIL IN THE ELEVATOR HYDRAULIC SYSTEM. CUSTOM TANK SIZES CAN BE PROVIDED BY LIBERTY PUMPS.

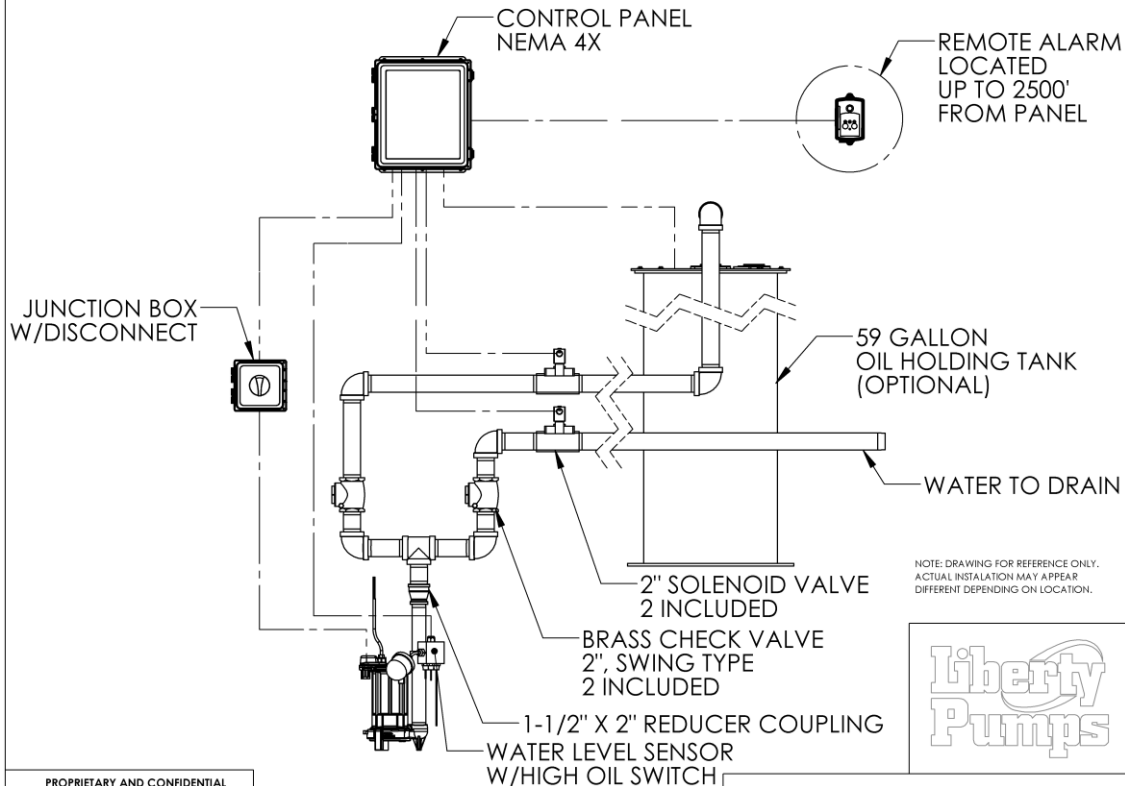

PROPRIETARY AND CONFIDENTIAL
THE INFORMATION CONTAINED IN THIS DRAWING IS THE SOLE PROPERTY OF LIBERTY PUMPS. ANY REPRODUCTION IN PART OR AS A WHOLE WITHOUT THE WRITTEN PERMISSION OF LIBERTY PUMPS IS PROHIBITED.

ELV AUTO-VALVE SERIES, SIMPLEX OILTECOR CONTROL-GENERAL ARRANGEMENT

DWG. NO.

SIZE
A

DATE: 12/03/14

REV.
A

APPLICATION

DO NOT SCALE DRAWING

SCALE:1:4

WEIGHT: LBS

SHEET 1 OF 1

Auto-Valve Series: ELV280-VS/VST Pump Dimensional Data

NOTES:

1. PUMP DISCHARGE IS 1-1/2" FNPT.
2. 2" X 1-1/2" REDUCER COUPLING INCLUDED IN KIT.

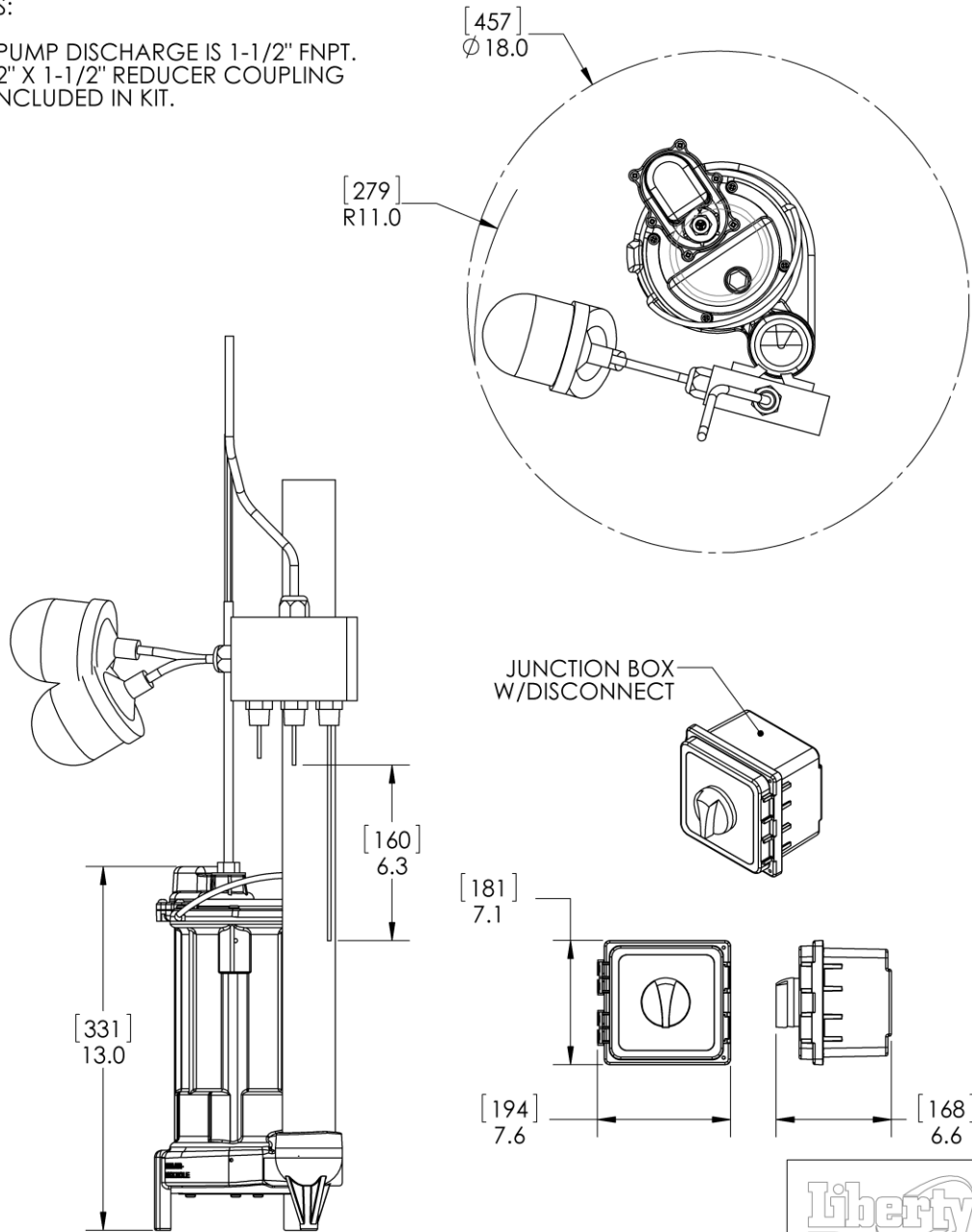

PROPRIETARY AND CONFIDENTIAL
 THE INFORMATION CONTAINED IN THIS DRAWING IS THE SOLE PROPERTY OF LIBERTY PUMPS. ANY REPRODUCTION IN PART OR AS A WHOLE WITHOUT THE WRITTEN PERMISSION OF LIBERTY PUMPS IS PROHIBITED.

| | |
|-------------|----------------------|
| APPLICATION | DO NOT SCALE DRAWING |
|-------------|----------------------|

| | | |
|---|----------------|--------------|
| ELV280 AUTO-VALVE SERIES DIMENSIONAL | | |
| DWG. NO. | DATE: 12/03/14 | REV. A |
| SCALE: N/A | WEIGHT: LBS | SHEET 1 OF 1 |

Auto-Valve Series: ELV290-VS/VST Pump Dimensional Data

NOTES:

1. PUMP DISCHARGE IS 1-1/2" FNPT.
2. 2" X 1-1/2" REDUCER COUPLING INCLUDED IN KIT.

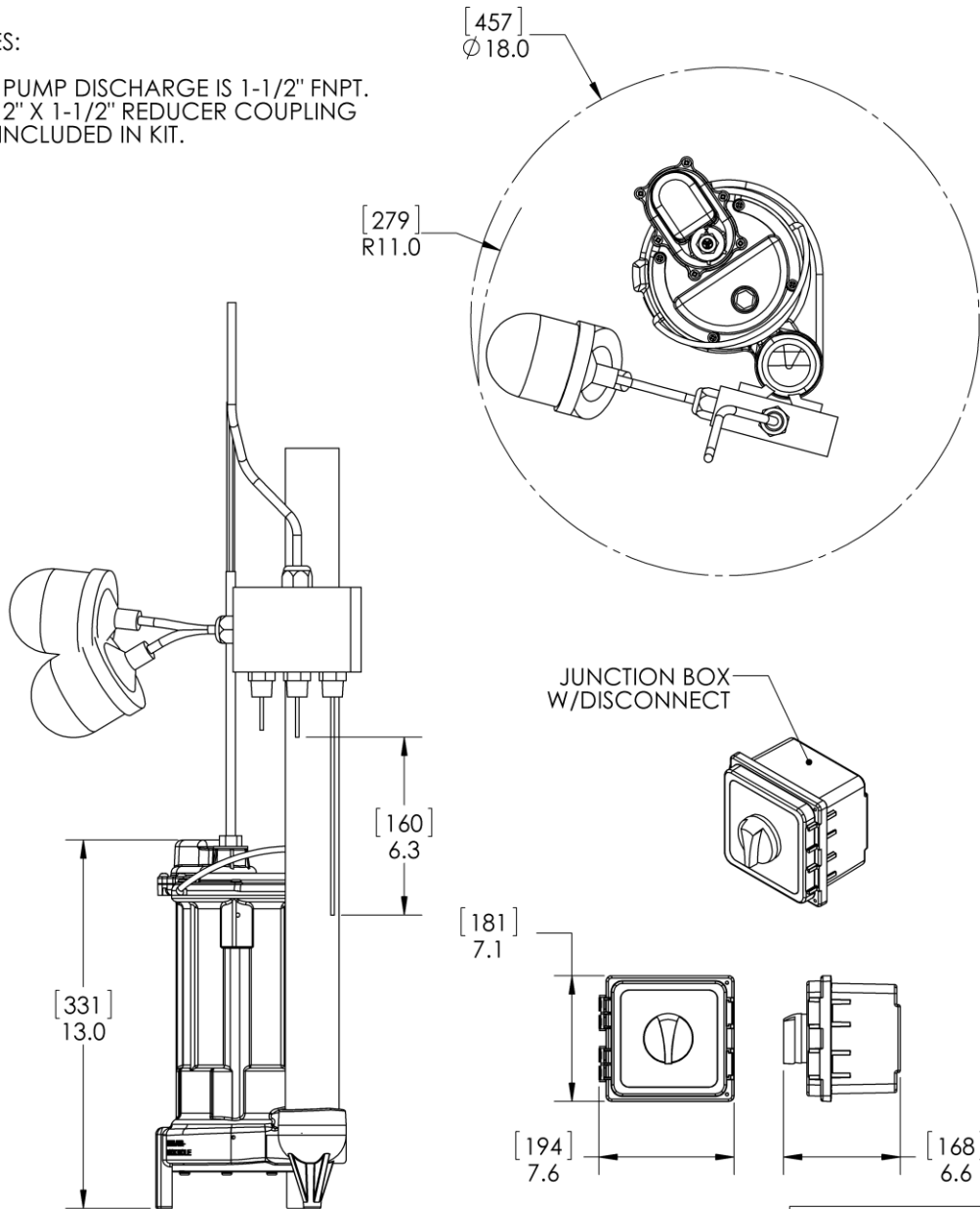

PROPRIETARY AND CONFIDENTIAL
 THE INFORMATION CONTAINED IN THIS DRAWING IS THE SOLE PROPERTY OF LIBERTY PUMPS. ANY REPRODUCTION IN PART OR AS A WHOLE WITHOUT THE WRITTEN PERMISSION OF LIBERTY PUMPS IS PROHIBITED.

APPLICATION DO NOT SCALE DRAWING

| | | |
|--------------------------------------|--------------------|------------------|
| ELV290 AUTO-VALVE SERIES DIMENSIONAL | | |
| DWG. NO. | | |
| SIZE A | DATE: 12/03/14 | REV. A |
| SCALE: N/A | WEIGHT: LBS | SHEET 1 OF 1 |



Auto-Valve Series: ELVFL63-VS/VST Pump Dimensional Data

NOTES:

1. PUMP DISCHARGE IS 2" FNPT WITH A 1-1/2" FNPT FLANGE PROVIDED.

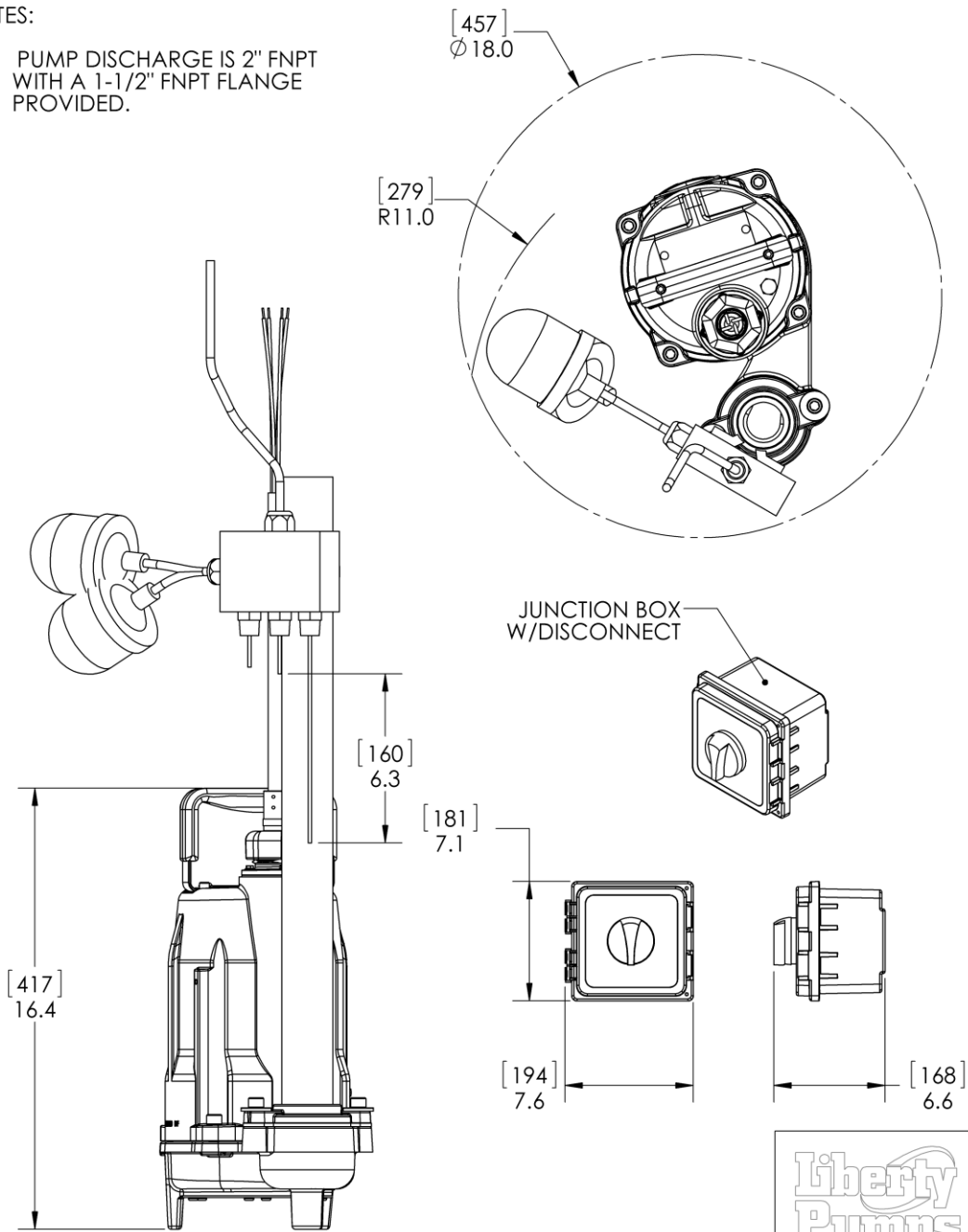

PROPRIETARY AND CONFIDENTIAL
 THE INFORMATION CONTAINED IN THIS DRAWING IS THE SOLE PROPERTY OF LIBERTY PUMPS. ANY REPRODUCTION IN PART OR AS A WHOLE WITHOUT THE WRITTEN PERMISSION OF LIBERTY PUMPS IS PROHIBITED.

APPLICATION DO NOT SCALE DRAWING

| | | |
|--|--------------------|------------------|
| ELVFL63 AUTO-VALVE SERIES DIMENSIONAL | | |
| DWG. NO. | | |
| SIZE A | DATE: 12/03/14 | REV. A |
| SCALE: N/A | WEIGHT: LBS | SHEET 1 OF 1 |

Auto-Valve Series: Valve Dimensional Data

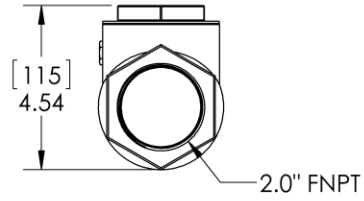
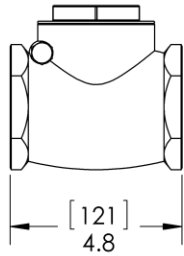

CHECK VALVE
2" BRASS
2 INCLUDED

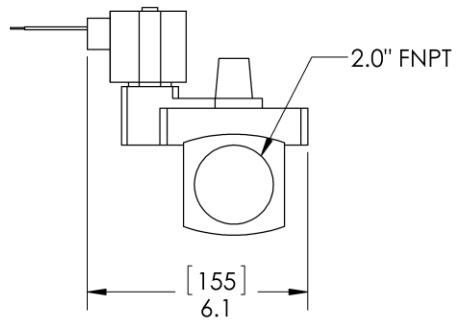
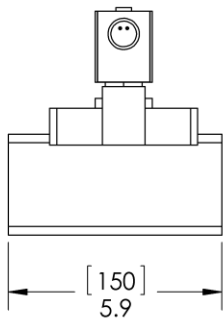
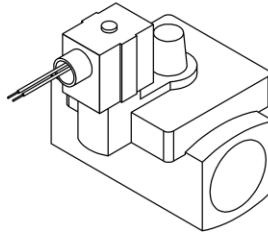
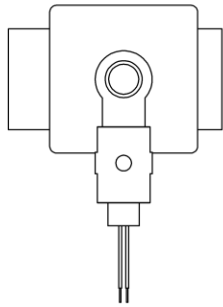

SOLENOID VALVE, NC, BRONZE
2 INCLUDED W/AUTOVALVE
SYSTEM

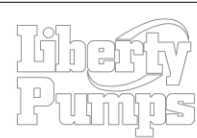

PROPRIETARY AND CONFIDENTIAL
THE INFORMATION CONTAINED IN THIS DRAWING IS THE SOLE PROPERTY OF LIBERTY PUMPS. ANY REPRODUCTION IN PART OR AS A WHOLE WITHOUT THE WRITTEN PERMISSION OF LIBERTY PUMPS IS PROHIBITED.

| | | |
|-------------|--|----------------------|
| APPLICATION | | DO NOT SCALE DRAWING |
|-------------|--|----------------------|

| | | |
|----------------------------------|----------------|--------------|
| AUTO-VALVE SERIES DIMENSIONAL | | |
| DWG. NO. | DATE: 12/03/14 | REV. A |
| SIZE A | SCALE: N/A | WEIGHT: LBS |
| | | SHEET 1 OF 1 |

Auto-Valve Series: Optional Oil Storage Tank Dimensional Data

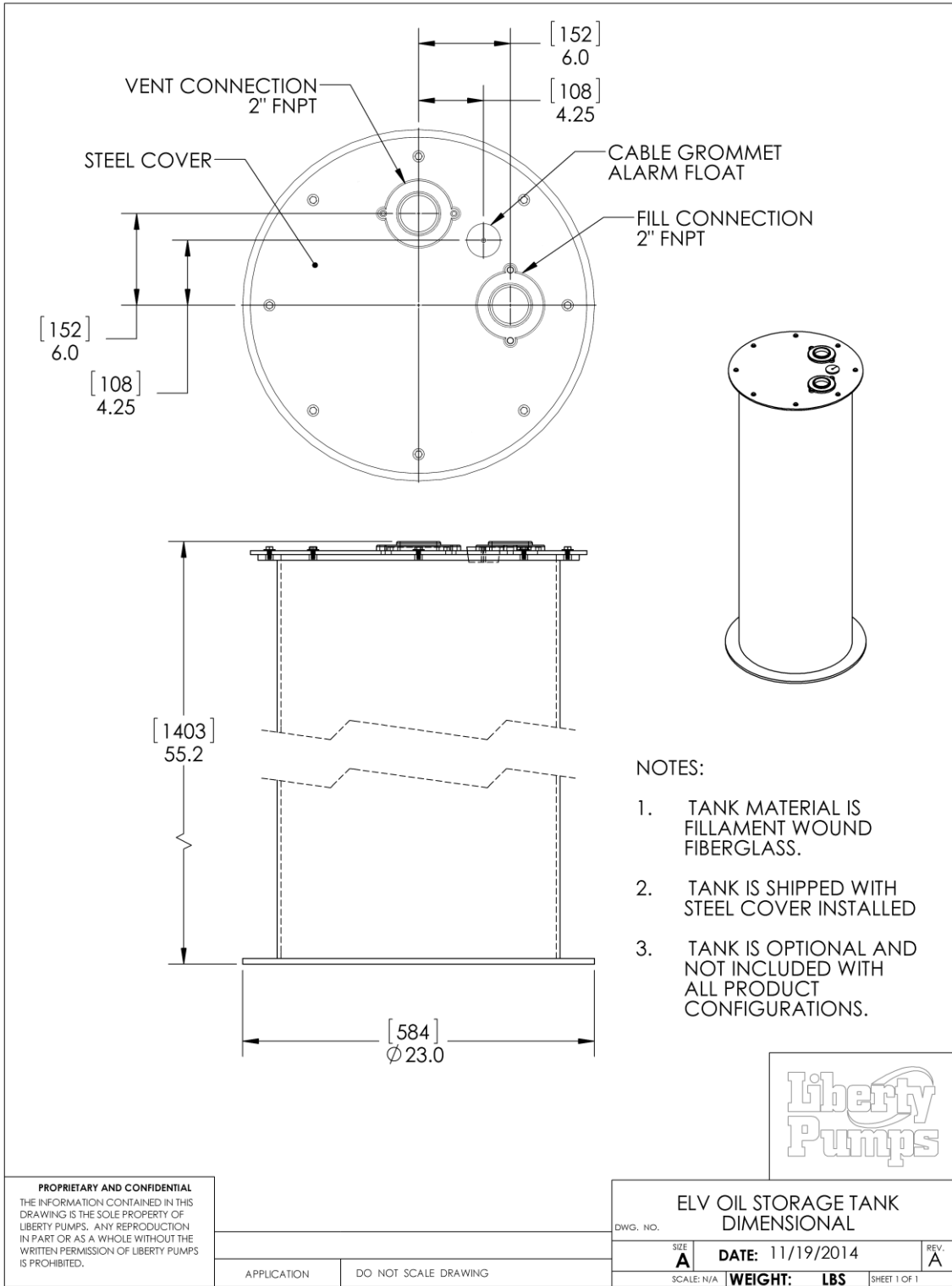

PROPRIETARY AND CONFIDENTIAL
 THE INFORMATION CONTAINED IN THIS DRAWING IS THE SOLE PROPERTY OF LIBERTY PUMPS. ANY REPRODUCTION IN PART OR AS A WHOLE WITHOUT THE WRITTEN PERMISSION OF LIBERTY PUMPS IS PROHIBITED.

APPLICATION: DO NOT SCALE DRAWING

| | | |
|---|--------------------|---------------|
| DWG. NO. ELV OIL STORAGE TANK DIMENSIONAL | | |
| SIZE A | DATE: 11/19/2014 | REV. A |
| SCALE: N/A | WEIGHT: LBS | SHEET 1 OF 1 |



Auto-Valve Series: Pump Electrical Data

| PUMP MODEL | HP | VOLTAGE | PHASE | FULL LOAD AMPS | LOCKED ROTOR AMPS | THERMAL OVERLOAD TEMP | STATOR WINDING CLASS | CORD LENGTH FT | DISCHARGE | AUTOMATIC |
|-------------|------|---------|-------|----------------|-------------------|-----------------------|----------------------|----------------|-----------|----------------|
| EV280-5BL | 1/2 | 115 | 1 | 8 | 23 | 105°C/ 221°F | B | 50 | 1 1/2" | YES W/ CONTROL |
| EV280HV-5BL | 1/2 | 230 | 1 | 4 | 12.5 | 105°C/ 221°F | B | 50 | 1 1/2" | YES W/ CONTROL |
| EV290-5BL | 3/4 | 115 | 1 | 10.4 | 24 | 120°C/ 248°F | B | 50 | 1 1/2" | YES W/ CONTROL |
| EV290HV-5BL | 3/4 | 230 | 1 | 5.3 | 13 | 105°C/ 221°F | B | 50 | 1 1/2" | YES W/ CONTROL |
| FL63M-5 | 6/10 | 208-230 | 3 | 5.6 | 25.3 | 105°C/ 221°F | B | 50 | 2" | YES W/ CONTROL |

Auto-Valve Series: Pump Technical Data

| IMPELLER | |
|---|---------------------------|
| EV280-5BL, EV280HV-5BL, EV290-5BL, EV290HV-5BL | VORTEX ENGINEERED POLYMER |
| FL63-5 | MULTI-VANE CAST IRON |
| SOLIDS HANDLING SIZE | 3/4" |
| PAINT | POWDER COAT |
| MAX LIQUID TEMP | 60°C/ 140°F |
| MAX STATOR TEMP | CLASS B 130°C/ 266°F |
| THERMAL OVERLOAD | |
| EV280-5BL, EV280HV-5BL, EV290HV-5BL, FL63-5 | 105°C/ 221°F |
| EV290-5BL | 120°C/ 248°F |
| MOTOR HOUSING/ VOLUTE | CLASS 25 CAST IRON |
| SHAFT | STAINLESS |
| HARDWARE | STAINLESS |
| ORINGS | BUNA N |
| MECHANICAL SEAL | UNITIZED CERAMIC CARBON |
| WEIGHT | |
| EV280-5BL, EV280HV-5BL | 30 LBS |
| EV290-5BL, EV290HV-5BL | 31 LBS |
| FL63-5 | 57 LBS |
| MIN. SUMP SIZE | Ø18" X 30" |

Auto-Valve Series: Controls Electrical Data

| MODEL | CONTROLS INPUT VOLTAGE | PUMP INPUT VOLTAGE | MAX PUMP CURRENT | VALVE POWER |
|--------------------------|------------------------|--------------------|------------------|-------------|
| ELV280-VS/ELV280-VST | 120 VAC, 1PH | 120 VAC, 1PH | 15A | 120VAC, 1PH |
| ELV280HV-VS/ELV290HV-VST | 120 VAC, 1PH | 230 VAC, 1PH | 15A | 120VAC, 1PH |
| ELV290-VS/ELV290-VST | 120 VAC, 1PH | 120 VAC, 1PH | 15A | 120VAC, 1PH |
| ELV290HV-VS/ELV290HV-VST | 120 VAC, 1PH | 230 VAC, 1PH | 15A | 120VAC, 1PH |
| ELVFL63-VS/ELVFL63-VST | N/A* | 208/230 VAC, 3 PH | 4-6.3A | 120VAC, 1PH |

*3 phase models utilize a multi-tap transformer to power the controls and valves.

Auto-Valve Series Specifications

1.01 GENERAL:

The contractor shall provide labor, material, equipment, and incidentals required to provide _____(QTY) Simplex OilTector® Systems as specified herein. The pump models covered in this specification are ELV Series pumps. The pump furnished for this application shall be model _____as manufactured by Liberty pumps.

2.01 OPERATING CONDITIONS:

Each submersible pump shall be rated for ____hp, ____volts, ____ phase, 60 Hz, & 3450 RPM. The unit shall produce ____G.P.M. at ____ feet of total dynamic head.

The submersible pump shall be capable of handling water with ____ solid handling capability. The submersible pump shall have a shut-off head of ____ feet and a maximum flow of ____ GPM @ 5 feet of total dynamic head.

The OilTector® Auto-valve system Pairs a touch screen controller with a proven Liberty sump pump to eliminate unwanted water from elevator sump while preventing the unwanted discharge of oil to the sewer system or environment.

The OilTector® Controller uses a sump probe, which consists of 3 metal probes and a float switch. When water collects in the sump, and contacts both the lowest and the middle probe, the water solenoid valve opens and the pump will eliminate the water to the sewer drain until the level is below the lowest probe. If the water level increases to the highest probe, the high water alarm sounds and the pump runs to eliminate the water in the sump.

In the event of an oil leak, the spilled oil will collect in the sump and float on the surface of the water. Once the layer is thick enough to trip the high oil float, the pump will eliminate the oil and water in the sump; the water will be pumped to the drain and then the oil will be routed to the waste oil storage tank preventing unwanted contamination.

The OilTector® controller additionally provides a means for manual pump and valve operation, dry contacts for alarm conditions, and data logging to document all operational activity.

3.01 CONSTRUCTION:



Each centrifugal sump pump shall be equal to the c^{us} Certified ELV-Series pumps as manufactured by Liberty Pumps, Bergen NY. The castings shall be constructed of class 25 cast iron. The motor housing shall be oil filled to dissipate heat. Air filled motors shall not be considered equal since they do not properly dissipate heat from the motor. All mating parts shall be machined and sealed with a Buna-N o-ring. All fasteners exposed to the liquid shall be stainless steel. The motor shall be protected on the top side with sealed cord entry plate with molded pins to conduct electricity eliminating the ability of water to enter internally through the cord. The motor shall be protected on the lower side with a unitized ceramic/carbon seal with stainless steel housings and spring or engineered double lip seal with stainless steel springs. The pump shall be furnished with stainless steel handle.

4.01 ELECTRICAL POWER CORD

The submersible pump shall be supplied with a 50 feet of multi-conductor power cord. It shall be cord type BLACK UL 16-3 SJEOW 300V 105°C or BLACK 14-4 SEOW 600V 105°C

The power cord shall be sized for the rated full load amps of the pump in accordance with the National Electric Code. The power cable shall not enter the motor housing directly but will conduct electricity to the motor by means of a water tight compression

fitting cord plate assembly, with molded pins to conduct electricity. This will eliminate the ability of water to enter internally through the cord, by means of a damaged or wicking cord.

5.01 MOTORS

Single phase motors shall be oil filled, capacitor start, class B insulated NEMA B design, rated for continuous duty. At maximum load the winding temperature shall not exceed 135 degrees C unsubmerged. Since air filled motors are not capable of dissipating heat they shall not be considered equal. Single phase motors shall have an integral thermal overload switch in the windings for protecting the motor. Three phase motors shall be used with an appropriate controller with integral overload protection. The capacitor circuit on single phase motors shall be mounted internally in the pump.

6.01 BEARINGS AND SHAFT

An upper and lower ball bearing shall be required. The lower ball bearing shall be a single ball / race type bearing. Both bearings shall be permanently lubricated by the oil, which fills the motor housing. The motor shaft shall be made of 300 or 400 series stainless steel.

7.01 SEALS

The pump shall have a unitized carbon / ceramic seal with stainless steel housings and spring, or engineered double lip seal with stainless steel springs. The motor plate / housing interface shall be sealed with a Buna-N o-ring.

8.01 IMPELLER

The impeller shall be vortex style made of an engineered polymer, with pump out vanes on the back shroud to keep debris away from the seal area. It shall be threaded to the motor shaft.

9.01 CONTROLS

The controls shall be housed in a NEMA 4X rated enclosure with a transparent hinged door. The door shall be closed with hasps which are capable of being padlocked. The enclosure shall have a painted steel dead front to protect the user from the panel wiring while also allowing access to the Touchscreen controls and power breakers.

The primary means of operator interface shall be by way of a touchscreen interface. This interface shall provide graphic feedback of the system status as well as allow for selection of Auto/Manual control of the pump and valves. The controls shall include dry contact for the alarm status of the system.

The controls shall have a method to electronically record the operation and status of the system while saving this record to a removable USB storage device. The data which has been logged shall be downloadable to via USB connection in a CSV format.

The single phase control panel shall be wired such that the pump and the controls are on two separate power circuits. These circuits shall each be protected by a circuit breaker, sized in accordance to the loading of the circuit. The three phase control panel shall utilize a single three phase power source. This circuit shall each be protected by a circuit breaker, sized in accordance to the loading of the circuit.

The control unit has three probes and a float ball switch. The pump will activate when the middle probe contacts water, and will remain on until the first, longest probe no longer is in contact with water. A high water alarm is activated when third or shortest probe contacts water. The system will ignore a small film of oil, however larger volumes of oil will be detected when the alarm probe does not detect water and the float ball activates. The system will continue to operate, removing water not oil from the vault even when oil has been detected.

When the oil layer present is thick enough to change the state of the float switch, and there is not water in the sump, the controller shall open the oil valve and run the pump to evacuate the oil from the sump. When the oil layer present is thick enough to change the state of the float switch, and water is detected in the sump, the controller shall open the water valve and run the pump to evacuate the water from the sump, and subsequently close the water valve and open the oil valve with the pump moving the oil to the holding tank for safe disposal.

10.01 VALVES

The system shall utilize (2) 2" Normally Closed Pilot-operated Solenoid Valves, with cast bronze bodies and NBR seals. These valves shall be operated with 120VAC single phase power. These valves will be utilized in the water and oil discharge lines, and shall be composed of materials suitable for use with the fluids pumped.

The system shall utilize (2) 2" swing type brass check valves, with NPT connections. These valves shall be installed in the discharge lines, upstream from the solenoid valves, in a manner to prevent backflow through the pump.

11.01 PAINT

The exterior of the casting shall be protected with powder coat paint.

12.01 SUPPORT

The pump shall have cast iron support legs, enabling it to be a free standing unit.

13.01 SERVICEABILITY

Components required for the repair of the pump shall be shipped within a period of 24 hours.

14.01 TESTING

The pump shall have a ground continuity check and the motor chamber shall be Hi-potted to test for electrical integrity, moisture content and insulation defects. The motor and volute housing shall be pressurized, and an air leak decay test is performed to ensure integrity of the motor housing. The pump shall be run, voltage current monitored, and the tester checks for noise or other malfunction.

15.01 QUALITY CONTROL

The pump shall be manufactured in an ISO 9001 certified Facility.

16.01 WARRANTY

Standard limited warranty shall be 3 years.