

# 12" ROUND GRATE

(317)346-4110  
www.drainagesolutionsinc.com

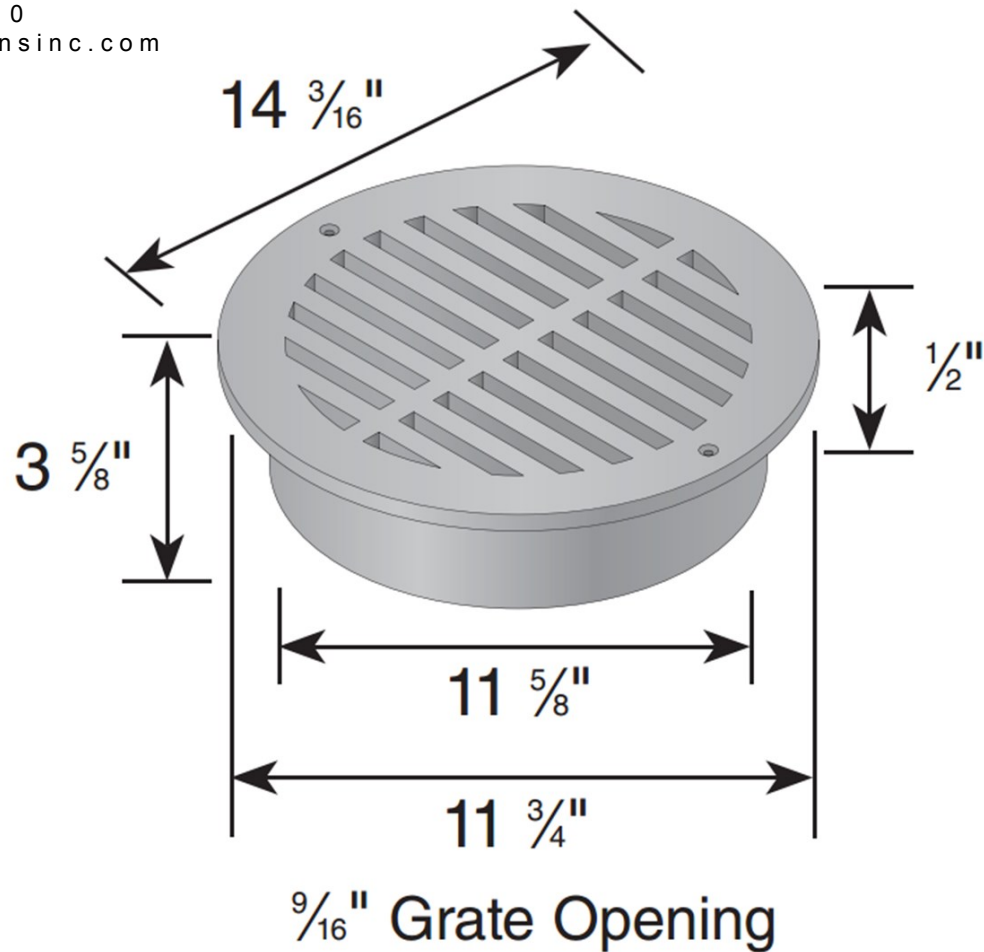

Material: UV Protected High Density Polyethylene (HDPE)

Colors: Black (1240), Green (1250), Gray (1260)

Weight: 2.66 lbs

Fits: 12" SDR-35, Corrugated, SCH-40, Class 125, & Double wall pipes

Grate Openings: 46.00 in<sup>2</sup> open space

Will accommodate 140.72 gallons per minute with 1/2" of head.

## Load Recommendation Guide



### Class B

- Loads of 61-175 psi.
- Recommended for medium-duty pneumatic tire traffic, autos and light trucks at speeds less than 20 m.p.h.

**Note:** Some installations may require a concrete collar to meet load rating. Loads are based on encasing product in concrete. Product must be installed using NDS instructions.

