

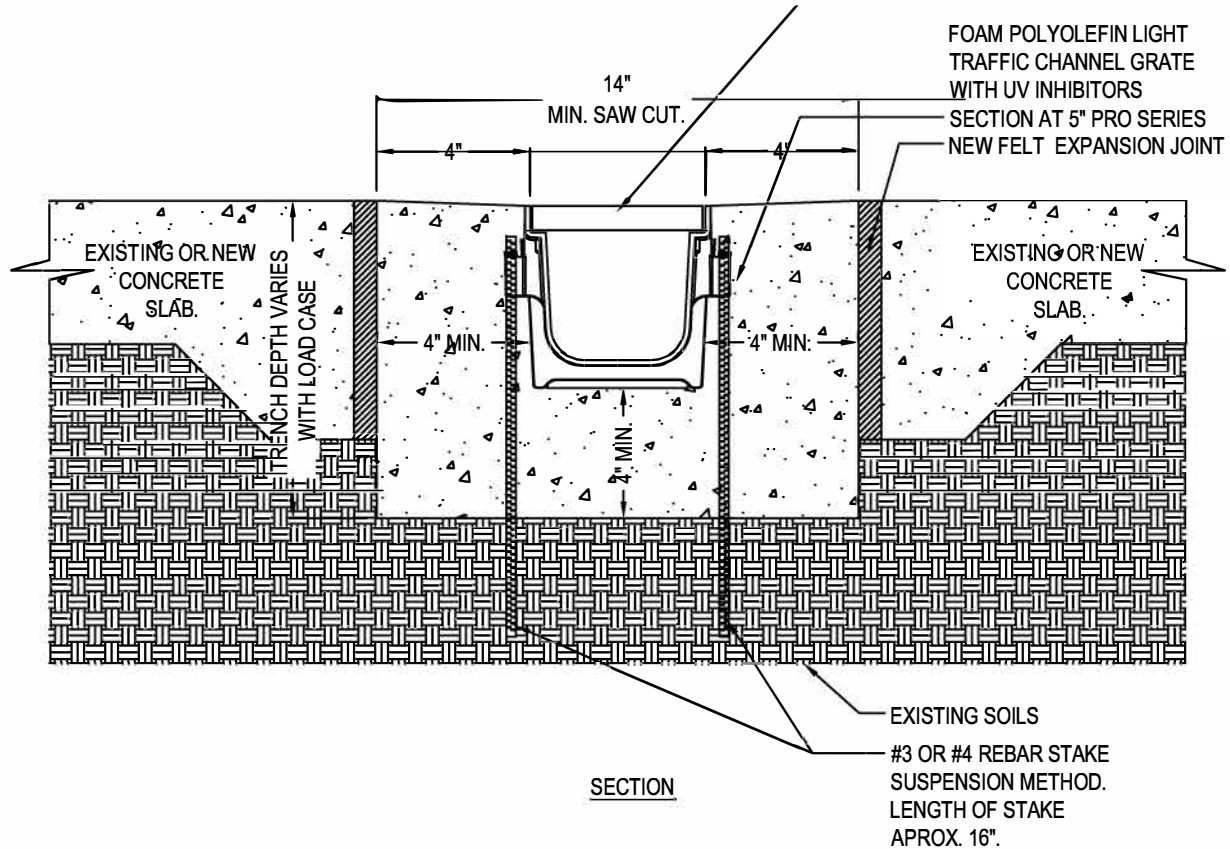

NDS[™]
WE PUT WATER IN ITS PLACE



(317) 346-4110
www.drainagesolutionsinc.com



NOTES:

1. CHANNELS TO BE INSTALLED WITH GRATE. GRATE TO BE PROTECTED FROM CONCRETE POUR
2. INSTALLATION TO BE COMPLETED IN ACCORDANCE WITH MANUFACTURER'S SPECIFICATIONS.
3. DO NOT SCALE DRAWING.
4. THIS DRAWING IS INTENDED FOR USE BY ARCHITECTS, ENGINEERS, CONTRACTORS, CONSULTANTS AND DESIGN PROFESSIONALS FOR PLANNING PURPOSES ONLY.
5. ALL INFORMATION CONTAINED HEREIN WAS CURRENT AT THE TIME OF DEVELOPMENT BUT MUST BE REVIEWED AND APPROVED BY THE PRODUCT MANUFACTURER TO BE CONSIDERED ACCURATE.

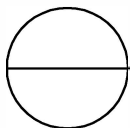

PRO SERIES CHANNEL DRAIN SYSTEM

5" PRO SERIES INSTALLATION DETAIL - LOAD CLASS 'A' & 'B' - 4" ENCASEMENT REBAR SUSPENSION