

6" ROUND GRATE

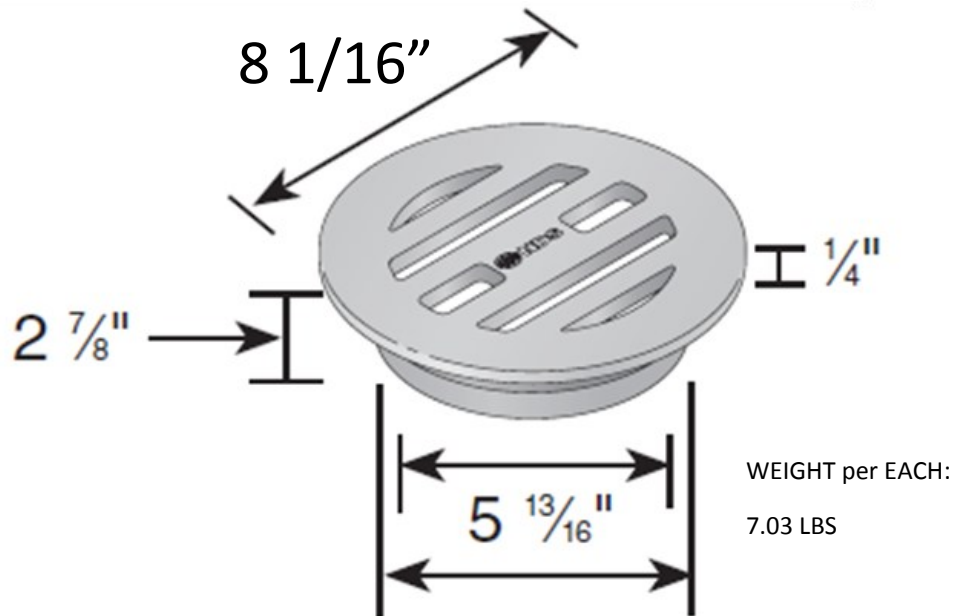

Material: Ductile Iron
 Colors: Black (D6)
 Fits: NDS Spee-D Basin, 6" Corrugated and Sewer and Drain pipe.
 This is not a custom grate and qualifies for normal NDS freight terms.
 Opening: 7.05 in² open space
 Will accommodate 21.57 gallons per minute with 1/2" of head

Load Recommendation Guide



Class D

- Loads of 326-575 psi.
- Recommended for heavy-duty hard tire forklifts at speeds less than 20 m.p.h., H-20 rated.



**DRAINAGE
SOLUTIONS, INC**

(317) 346-4110

www.drainagesolutionsinc.com

