



NDS®
We put water in its place



(317) 346-4110
www.drainagesolutionsinc.com

NDS 9" SQUARE TAPERED
POLYPROPYLENE CATCH
BASIN W/ U.V. INHIBITORS
THICKEN EDGE AT BASIN

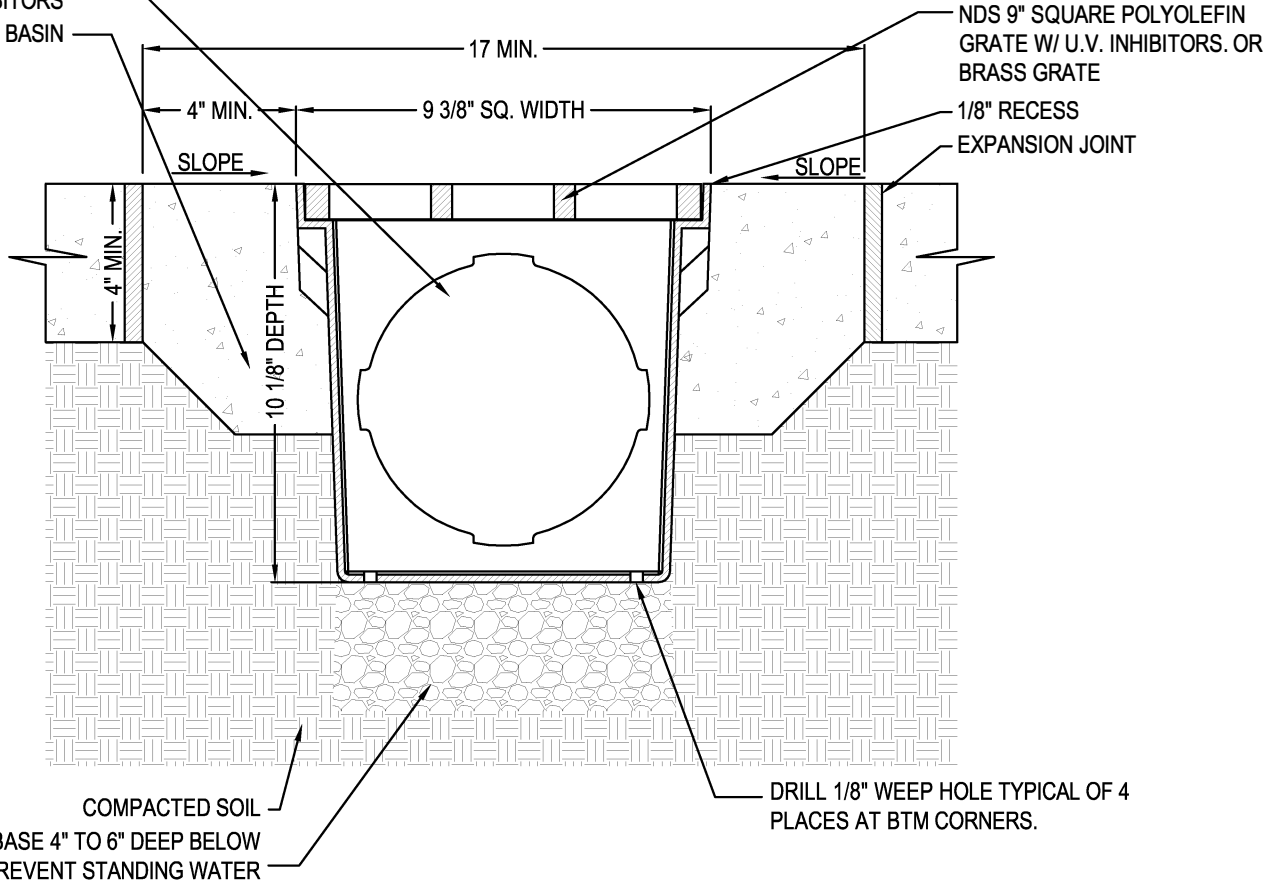

SECTION

NOTES:

1. GRATE TO BE ATTACHED TO CATCH BASIN WITH SCREW PROVIDED AT TIME OF INSTALLATION.
2. RISER CAN BE CUT TO ACHIEVE EXACT ELEVATION.
3. DO NOT USE OVER 5 RISERS WITH CATCH BASIN.
4. EXISTING SOILS SHOULD BE EVALUATED TO ENSURE PROPER STRUCTURAL AND PERMEABILITY PROPERTIES.
5. INSTALLATION TO BE COMPLETED IN ACCORDANCE WITH MANUFACTURER'S SPECIFICATIONS.
6. DO NOT SCALE DRAWING.
7. THIS DRAWING IS INTENDED FOR USE BY ARCHITECTS, ENGINEERS, CONTRACTORS, CONSULTANTS AND DESIGN PROFESSIONALS FOR PLANNING PURPOSES ONLY.
8. ALL INFORMATION CONTAINED HEREIN WAS CURRENT AT THE TIME OF DEVELOPMENT BUT MUST BE REVIEWED AND APPROVED BY THE PRODUCT MANUFACTURER TO BE CONSIDERED ACCURATE.

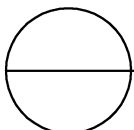

SQUARE CATCH BASIN

9" SQUARE CATCH BASIN - INSTALLATION FOR PEDESTRIAN AND LIGHT VEHICULAR TRAFFIC APPLICATIONS

