

DS-200H DURA-SLOPE FRAME

Dimension Key

- A. Length 24"
- B. Inner Width 6"
- C. Outer Width 6-3/8"

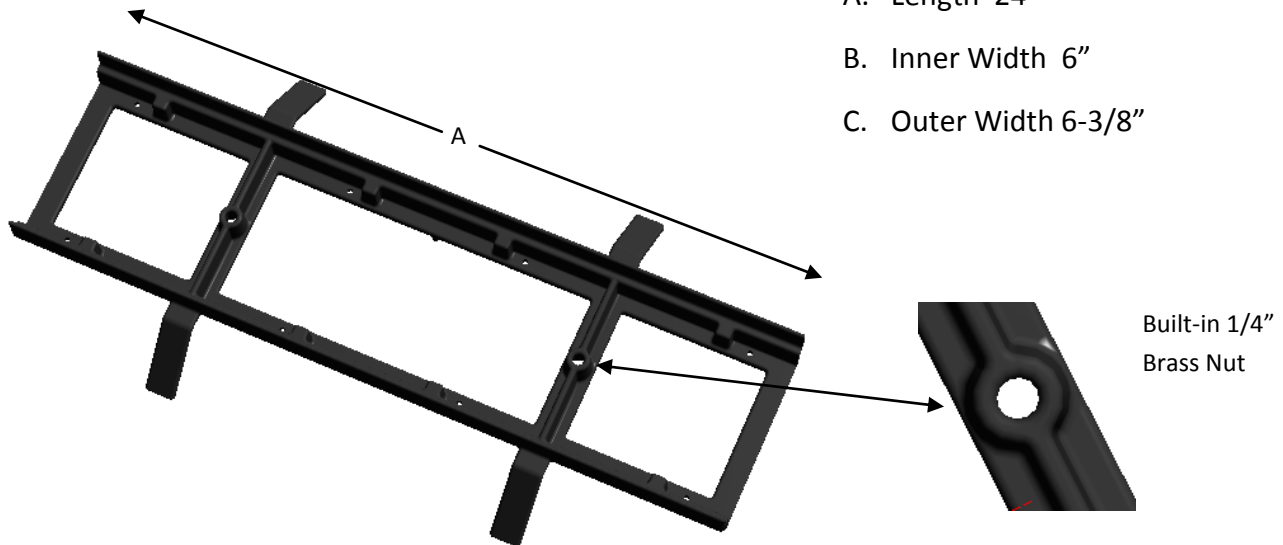

Part# DS-200H

Material: Ductile Iron Frame

Used with Dura Slope Trench Drain, 2 per channel.

Weight: 9.5 lbs.

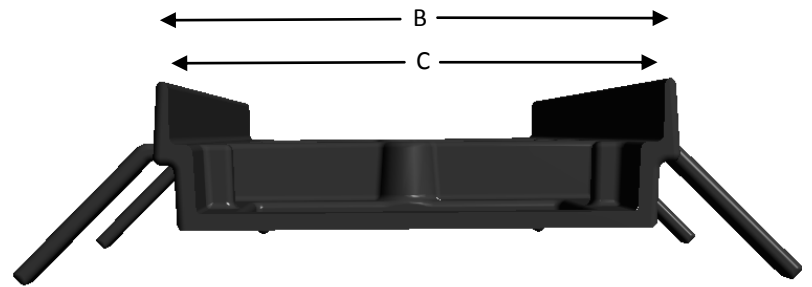

Dura Slope Ductile Iron Frame provides a Class D load rating of 326-575 psi and is suitable for heavy-duty hard tire equipment at speeds less than 20 mph. The DS-200 Ductile Iron Frame is recommended for use with pneumatic tire traffic such as fork lifts. The ductile iron frame can be used with the cast and ductile iron grates.

DS-122 (Grate Lock) and DS-225 (20x 2-1/2") are not necessary with the DS-200H Ductile iron Frame . Grate will connect to the DS-200H with standard screws #629



(3 1 7) 3 4 6 - 4 1 1 0

www.drainagesolutionsinc.com

