

## 2 FT. DURA SLOPE GRATE

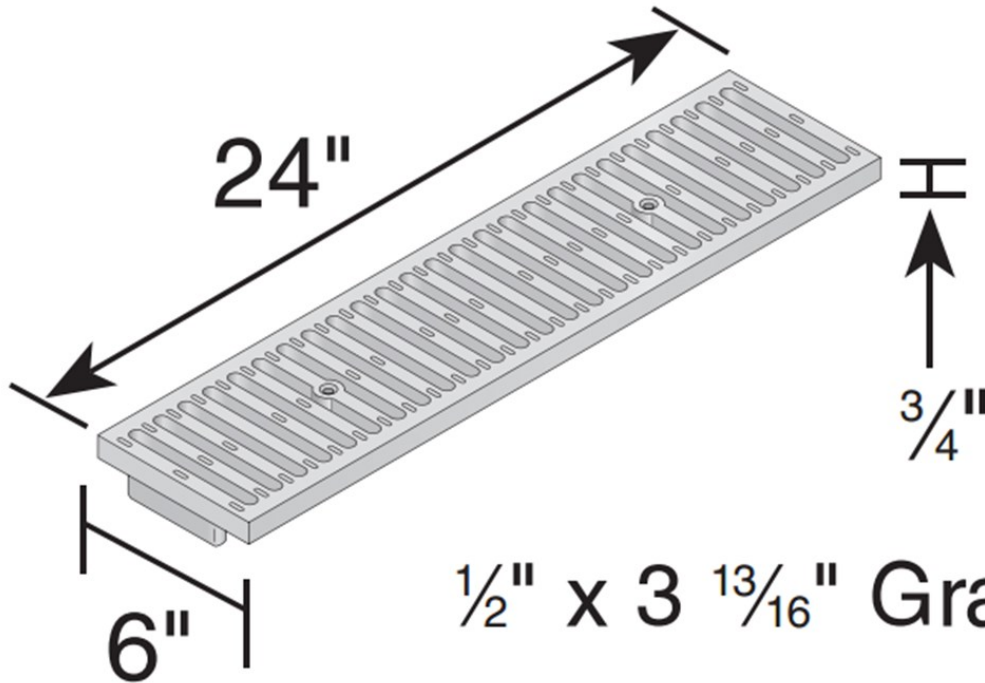

**1/2" x 3 13/16" Grate Opening**

### Load Recommendation Guide

Material: UV Protected High Density Polyethylene (HDPE)

Colors: White (660), Dark Gray (661), Gray (661LG), Green (662), Black (663), Sand (664), Brick Red (665)

Weight: 2.82 lbs each

Fits: Use with Dura Slope Channel Drains and Dura Slope Catch Basin (DS-340)

Grate Opening: 25.40 in<sup>2</sup> per foot

Will accommodate 77.70 gallons per minute per foot with 1/2" of head.



#### Class B

- Loads of 61-175 psi.
- Recommended for medium-duty pneumatic tire traffic, autos and light trucks at speeds less than 20 m.p.h.

**Note:** Some installations may require a concrete collar to meet load rating. Loads are based on encasing product in concrete. Product must be installed using NDS instructions.

#### ADA Compliance

NDS provides a wide selection of grates that are compliant with the Americans with Disabilities Act. The ADA Accessibility Guidelines For Buildings and Facilities Section 4.5.4 specifies that ground and floor grates "shall have spaces no greater than 1/2 in (13 mm) wide in one direction."

We are pleased to provide grates that comply with these requirements, so that no individual need be limited from accessing the area safely and confidently.

To see if a grate is ADA compliant, please check the description of the product in our [NDS Drainage Catalog](#); products that meet these requirements are marked "ADA compliant."

Like to find out more about ADA compliance and NDS? Send us your question and we'd be happy to help.

