

NDS®
We put water in its place



DRAINAGE SOLUTIONS, INC

(317) 346-4110

www.drainagesolutionsinc.com

EZ ROLL™ GRAVEL PAVER PRODUCT DESCRIPTION

CELL SIZE: 2-1/4" HEXAGONAL CELLS
STOCK ROLL SIZE'S: 3.87"W X 149"L (577 SQ. FT.)
NESTED HONEYCOMB CELL: 57, 888 PSF
LAYOUT COMPRESSIVE STRENGTH (OPEN CELL NO FILL) 402 PSI
EXCEEDS H2O LOADING

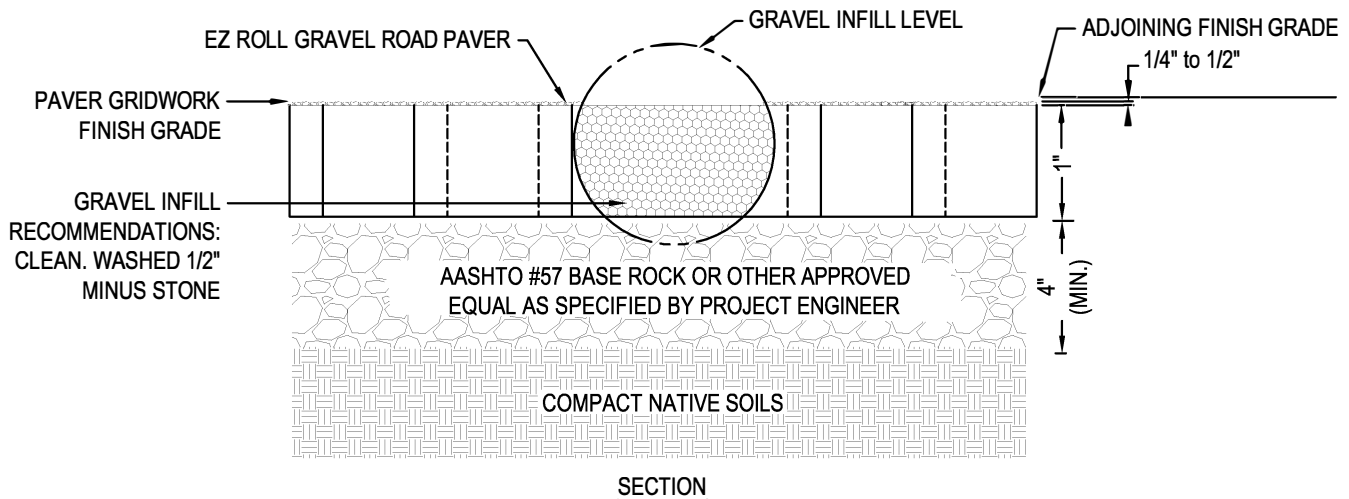
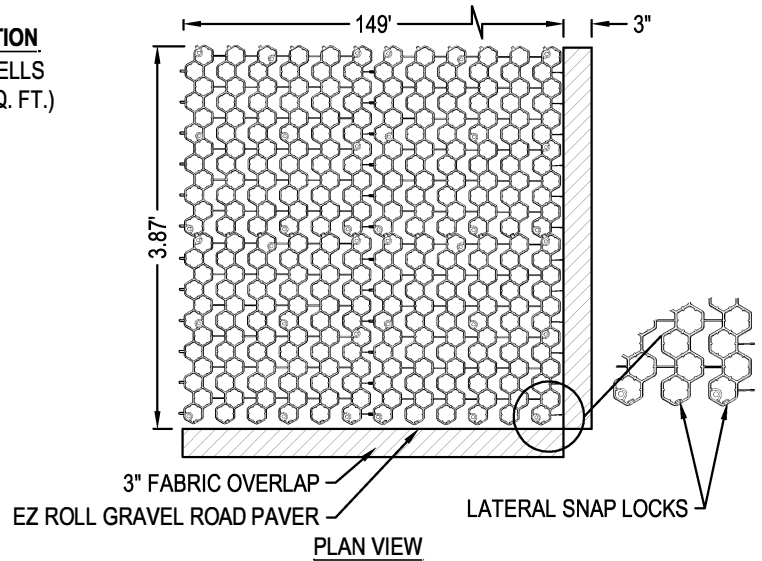

NOTES:

- EXISTING SOILS SHOULD BE EVALUATED TO ENSURE PROPER STRUCTURAL AND PERMEABILITY PROPERTIES.
- INSTALLATION TO BE COMPLETED IN ACCORDANCE WITH MANUFACTURER'S SPECIFICATIONS.
- DO NOT SCALE DRAWING.
- THIS DRAWING IS INTENDED FOR USE BY ARCHITECTS, ENGINEERS, CONTRACTORS, CONSULTANTS AND DESIGN PROFESSIONALS FOR PLANNING PURPOSES ONLY.
- ALL INFORMATION CONTAINED HEREIN WAS CURRENT AT THE TIME OF DEVELOPMENT BUT MUST BE REVIEWED AND APPROVED BY THE PRODUCT MANUFACTURER TO BE CONSIDERED ACCURATE.

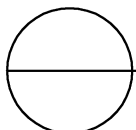

EZ ROLL GRAVEL PAVERS

LIGHT LOAD

