

# Flo-Well Assembly and Installation Sheet

Thank you for purchasing the Flo-Well system by NDS, the following information can help you maximize the benefits Flo-Well has to offer.

Form name LFWAS24WH

**WARNING:** Call before you dig. Contact your local utilities to create utility mark-out, and to avoid personal injury.  
**RECOMMENDED:** For all Flo-Well configurations install at least an appropriate 10 feet from foundations or structures.

## ASSEMBLY INSTRUCTIONS

**BEFORE YOU DIG:**  
 Contact the local utilities to create utility markout.

1. Place two panels side by side and align male tabs with female flange.
2. Pinch tabs and flange flush until panels interlock.
3. For final lock, slide male tabs downward until panel edges are leveled at top.
4. Repeat steps 1-3 for the third panel assembly.
5. Set cover over panel assembly and rotate until all three panel flanges are aligned with cover screw locations.

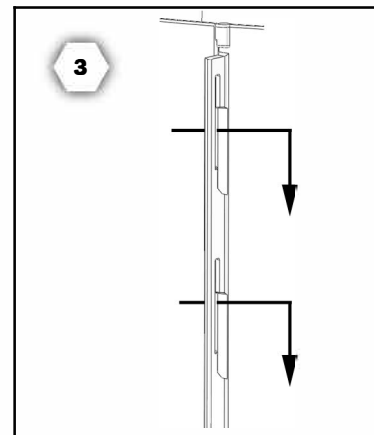
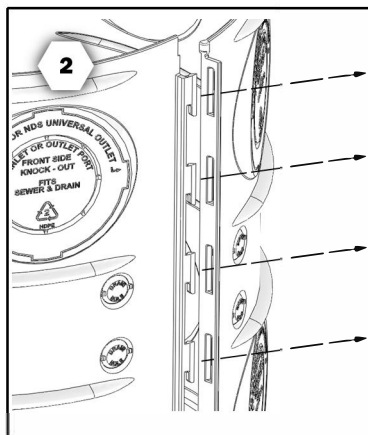
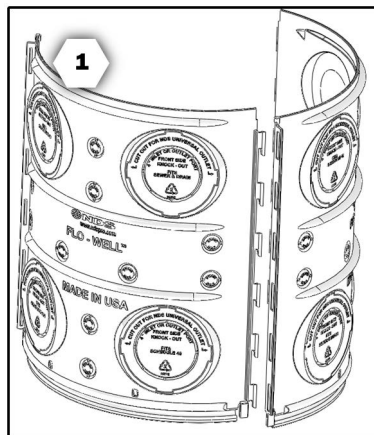

## DRY WELL SETUP

Required items: Small hammer, tape, fabric pack, NDS Universal Adapter, shovel, sand or recommended 3/4" stone gravel, 4" PVC pipe, jig-saw, and catch basin or downspout adapter

1. Strategically plan Flo-Well's location at a minimum distance of 10' from foundations.
  - a. Note: Take into consideration traffic and elevation conditions.
2. Once Flo-Well location is verified; dig a 4' wide by 4' deep hole.
3. Dig a trench from the end of the downspout at about 1' deep and 6" wide that slopes gradually towards the Flo-Well.
4. For pipe connection and leach direction, use small hammer to knock-out appropriate 1" and 4" panel ports or use jigsaw to cut out universal adapter port.
5. Wrap fabric around Flo-Well and secure with tape to prevent soil from entering drain holes.
6. Place Flo-Well assembly into ground and insert preferred 4" pipe into knocked-out port. Connect other end of 4" pipe to downspout either by catch basin or downspout adapter.
  - a. Note: Use NDS Universal Adapter and lock within panel universal adapter cut out for 3" and 6" pipes.
7. Backfill evenly around the Flo-Well with sand or recommended 3/4" stone gravel.
8. Bury Flo-well assembly with top at least 8" below the surface grade.

## Installation Example: Groundwater Recharge Hardpipe.

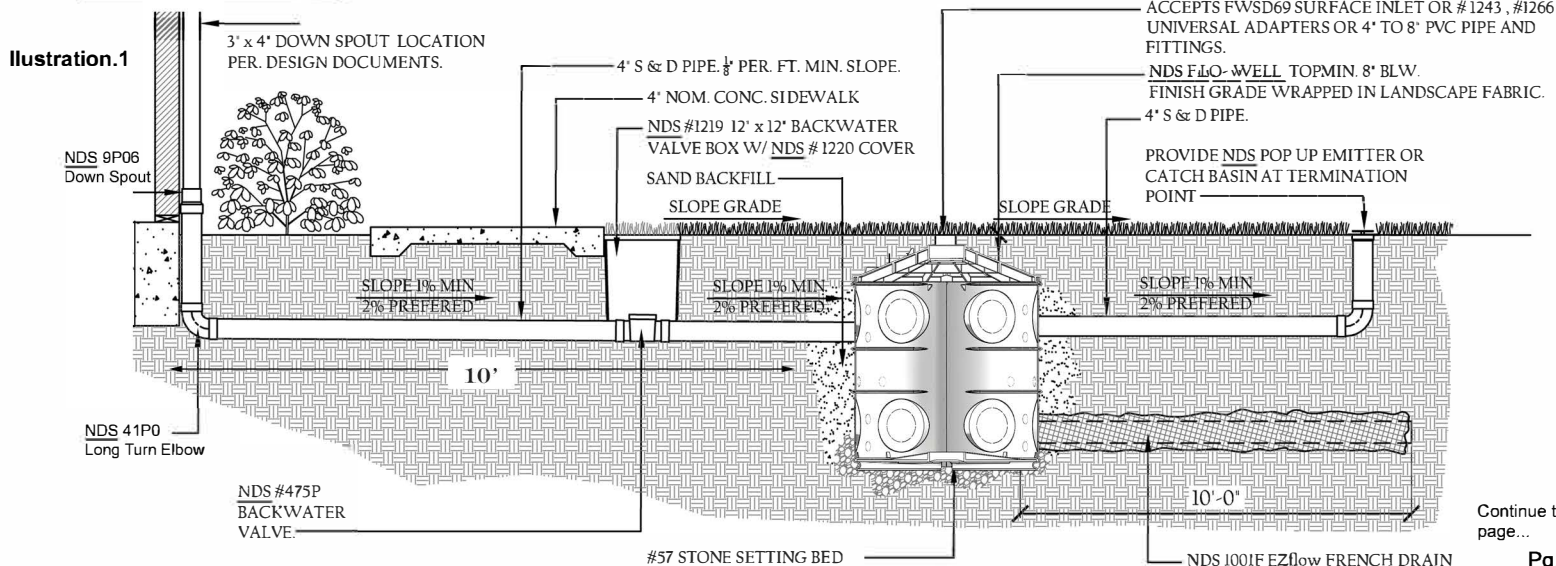

Continue to other page...

Continued...

**Optional 1:** See Illustration #2

**1. For light traffic applications:**

Install perforated or slotted SDR35 Pipe to increase vertical loading strength as shown.

**Optional 2:** See Illustration #1

**2. For water back up prevention:**

Vent downspout and use surface drain to allow overflow of excess water away from Flow-Well.

**3. To capture collected surface water:**

Place the Flow-Well at the lowest elevation point and install surface drain directly on top of cover.

Illustration #2

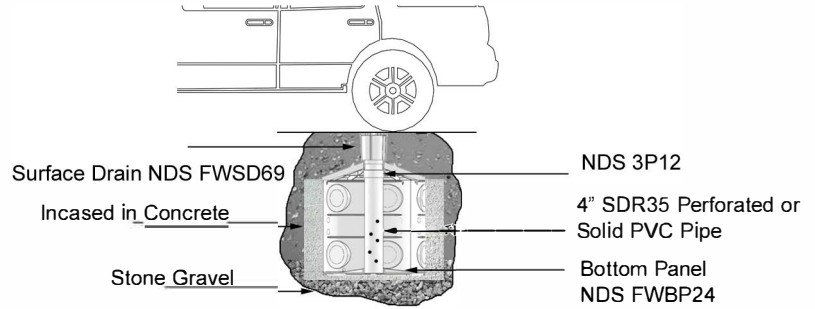

**New Flo-Well Features:**

- \*Added center 4" cover knock-out
- \*Added center 8" cover cut-out
- \*Added center "Universal Adapter" cover cut-out
- \*Added sump "U" cover cut-out
- \*Added 4" SCH 40 and 4" SDR 35 panel knock-out ports
- \*Added "Universal Adapter" panel cut-out

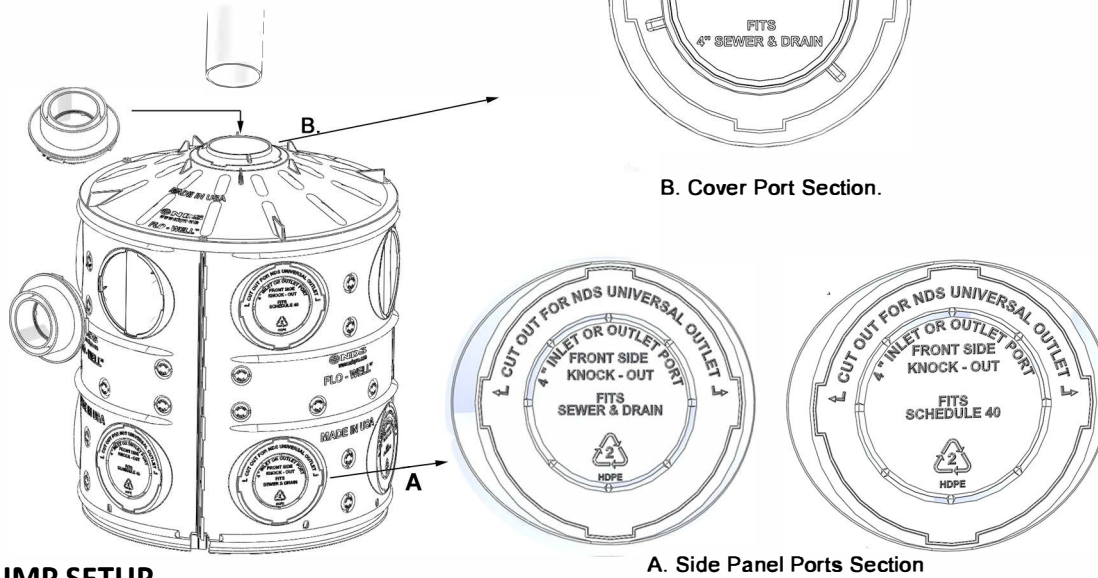

**SUMP PUMP SETUP**

Required items: Small hammer, tape, fabric pack, shovel, sand or recommended 3/4" stone gravel, jig saw, and pump

1. Follow assembly instructions in section 1 then dig a 4' wide by 4' deep hole at a minimum distance of 10' from foundations.
2. For each direction, use small hammer to knock-out appropriate 1" panel drain holes.
3. Wrap fabric around Flo-Well and secure with tape to prevent soil from entering drain holes.
4. Place Flo-Well assembly into ground and back fill around evenly up to cover with sand or recommended 3/4" stone gravel.
5. For sump pumps there are (3) options:
6. a.) Knock-out the center 4" plug on the top cover if your pump has a center discharge.
- b.) Cut-out 8" circle template on cover with jigsaw for drop-in sump, cover with 8" S&D pipe, cap or install NDS 8" rnd. Grate part # 1040.
- c.) Cut out the "U" shaped section on the top of cover with a jig saw for pedestal pumps with cut-off floats.
7. Attach pump to cover to insure smooth operation of cut-off float.

**For Installation details, please visit our website [www.NDSPRO.com](http://www.NDSPRO.com)**

[Ndspro.com](http://Ndspro.com) > Products and Solutions > Drainage Solutions > Flo-Well Drywell. The detail drawings will be under the 'Specify Flo-Well' category.

**IMPORTANT NOTICE:** It is your obligation to determine whether this product is suitable for your intended use and particular method of application. CONSULT YOUR LOCAL BUILDING OFFICIALS TO INSURE COMPLIANCE WITH ALL BUILDING CODES AND REQUIREMENTS.

**CAUTION:** The step-by-step installation instructions provided reflect mechanical assembly only. Additional information may be necessary to insure proper results for all applications. Consult with professionals to determine special soils conditions and structural requirements.



(317) 346-4110

[www.drainagesolutionsinc.com](http://www.drainagesolutionsinc.com)