



PIPE TOOLS & VISES
SINCE 1896

PVC DRILLING MACHINES

Reed's drilling machine for PVC is a low cost, excellent tool for making 3/4" and 1" taps through the saddle. The **DMPVC** drilling machine drills through the PVC pipe wall with the corporation stop inserted into the service saddle while under pressure. The **DMPVC** tool consists of the base unit and corp adapters in a carrying case. It utilizes Reed PVC shell cutters which are sold separately. The **DMPVCBASE** machine consists of the base unit, allowing the customer to purchase individual corp adapters and the necessary shell cutters for either 3/4" or 1" corporation size. **DMPVC COMPLETE** ships in a plastic toolbox and includes the DMPVC base along with corp adapters and PVC shell cutters for both 3/4" and 1" drilling projects. NPT to CC thread converters, and a 7/16" socket wrench complete the set.

Catalog No.	Item Code	Size	Weight	
			lbs	kg
DMPVC	04402	3/4 -1"	8.4	3.8
DMPVCBASE	04401	3/4 -1"	3.7	1.7
DMPVC Complete	04404	3/4 -1"	11.0	5.0
DMPVC3/4 KIT	04418	3/4" drilling only	5.3	2.4
DMPVC1 KIT	04420	1" drilling only	5.3	2.4

PVC SHELL CUTTERS

Shells drill through services saddles on PVC only. For use with Reed's DMPVC and Drilling Machines. They also fit Mueller D® and PL-2 machines.

WHY REED? Specifically designed for PVC, these cutters easily bore through even the heaviest wall pipe and retain the coupon and most cuttings.

Catalog No.	Item Code	Size
PL688	04385	3/4" NPT & AWWA
PL875	04386	1" NPT & AWWA

DRILLING MACHINE

The DM1000 and DM2000 series drilling machines drill through the pipe wall via the corporation stop inserted into the service saddle while under pressure. They use Reed D series drills or hole saws. The DMBASE machine consists of the base unit which allow the customer to purchase separately individual corp adapters, drill or hole saw adapters, along with necessary drills or hole saws. With shell cutters and necessary adapters, these units can also be used on C-900 PVC pipe. In addition to the base unit, Reed offers 9 other kits with a variety of corps adapters, drills, and/or hole saws included.

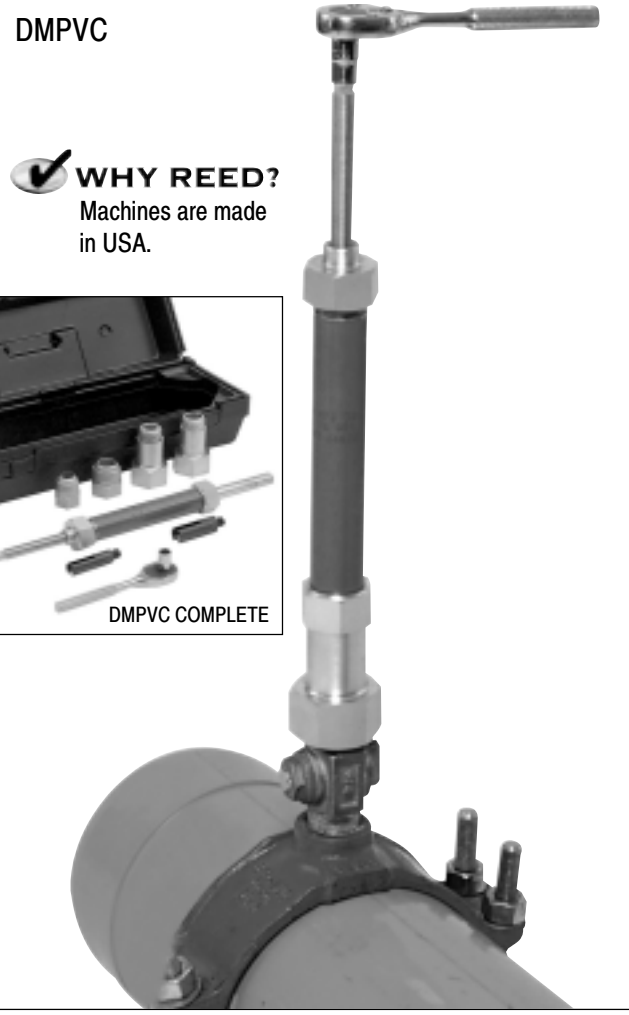

WHY REED?
Machines are made in USA.



REED ACCESSORIES

Catalog No.	Item Code	Size
DMCA75PVC	04426	3/4" PVC Corp Adapter
DMCA100PVC	04427	1" PVC Corp Adapter
DM75CONV	98472	3/4" CONVERTER: NPT TO AWWA
DM100CONV	98473	1" CONVERTER: NPT TO AWWA

See Reed's full-line catalog or www.reedmfgco.com for more details.



Reed Manufacturing Company

1425 West 8th Street, Erie, PA 16502 USA, Phone: 800-666-3691 or 814-452-3691, Fax: 800-456-1697 or 814-455-1697

www.reedmfgco.com