

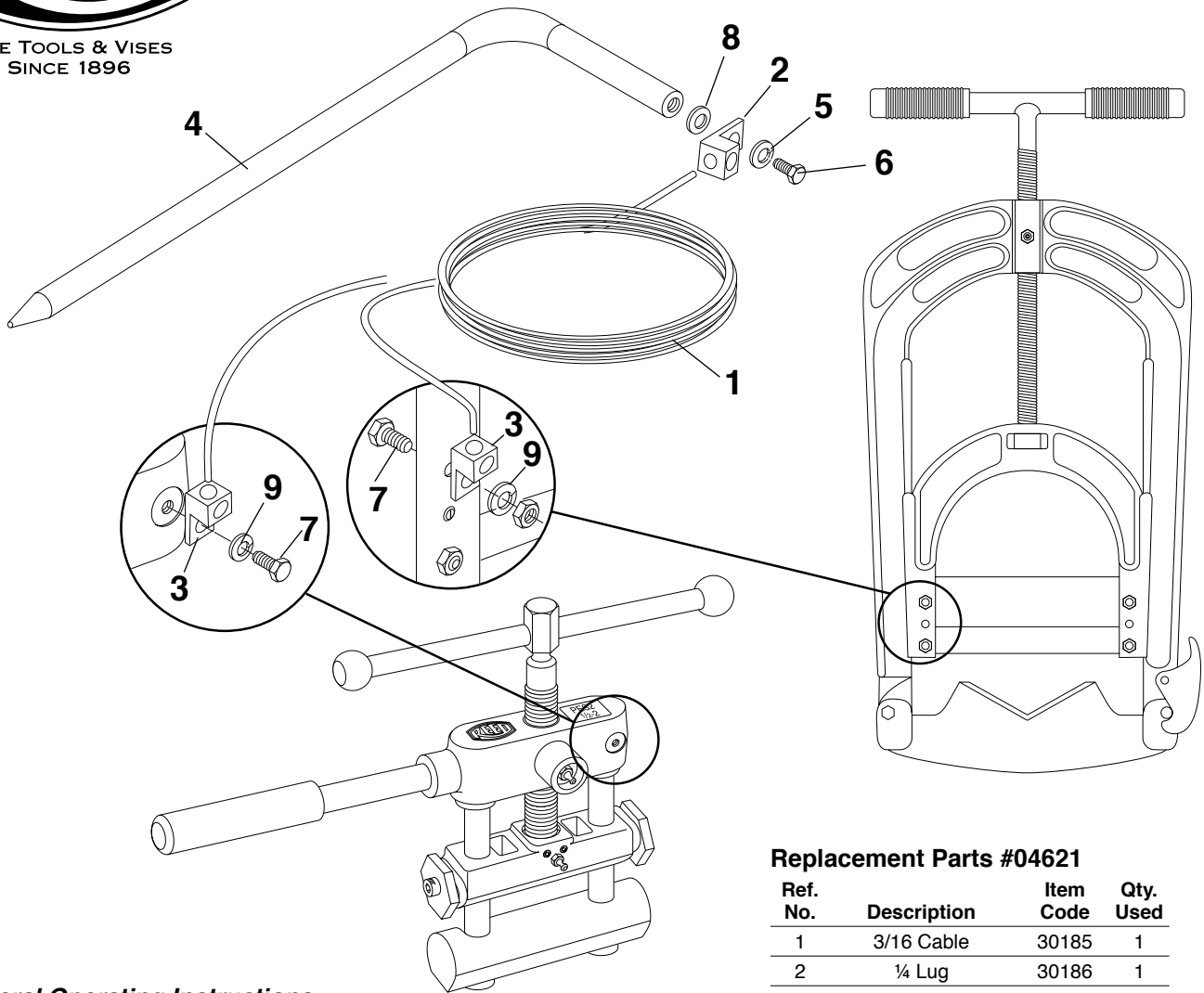

PIPE TOOLS & VISES
SINCE 1896

Static Grounding Device PEGR7



Replacement Parts #04621

Ref. No.	Description	Item Code	Qty. Used
1	3/16 Cable	30185	1
2	¼ Lug	30186	1
3	5/16 Lug	98063	1
4	½ Ground Probe	98081	1
5	¼ Lock Washer	34509	1
6	¼-20 Bolt	30184	1
7	5/16-18 Bolt	30134	1
8	9/32 Washer	30188	1
9	5/16 Lock Washer	30175	1

General Operating Instructions:

Because static electricity can build up on plastic pipe, there is a possibility of a spark discharge of sufficient energy to cause ignition if the proper air/gas mixture is present. Precautions can be taken to dissipate the charge, and minimize the possibility of an ignition. This will maximize the personal safety of the crew. These precautions should be followed as a minimum, conditions may require additional measures.

- To provide dissipation for static charge, wet down surfaces with conductive fluids and/or apply conductive films or fabrics to the pipe. Keep precautions in place until procedures are complete.
- Ground all tools.
- Periodically verify that continuity is maintained from ground probe to tool.

- Stop pushing once the vertical probe is no longer visible.
- Remove the Grounding Device only when all relevant work is complete and when tools are no longer in any contact with the serviced pipe.

PEGR7 Operating Instructions:

- Use the provided 5/16" bolt to securely fasten the unit to the tool.
- Before and periodically during the use of the Grounding Device, check the continuity between the tool and the Grounding Device.
- Use the formed copper handle and proceed to push the Grounding Device into the earth.

Repair Instructions, for an unlikely cable fracture:

- Trim away the existing bare wire from the damaged end.
- Strip approximately ½" of coating off of the trimmed end.
- Insert new bare wire into the set screw lug.
- The coating edge should lie just outside the set screw lug.
- Tighten the set screw to recommended 40-45 in.-lbs. of torque.

Additional information on static electricity is available in the PPI Handbook of Polyethylene Pipe 2nd Edition.

Reed Manufacturing Company
1425 West 8th Street
Erie, PA 16502 USA



(317) 346-4110

www.drainagesolutionsinc.com

Phone: 800-666-3691 or 814-452-3691
Fax: 800-456-1697 or 814-455-1697
www.reedmfgco.com

0918-50058