



(317) 346-4110

DRAINAGE SOLUTIONS, INC. www.drainagesolutionsinc.com

Torque Wrenches Operating Instructions

TW516 #02298
TW38 #02300



PIPE TOOLS & VISES
SINCE 1896

Features built into the TW516 and TW38:

Constant Torque Release -

Set and sealed at the factory. The torque value is stamped into the top of the handle.

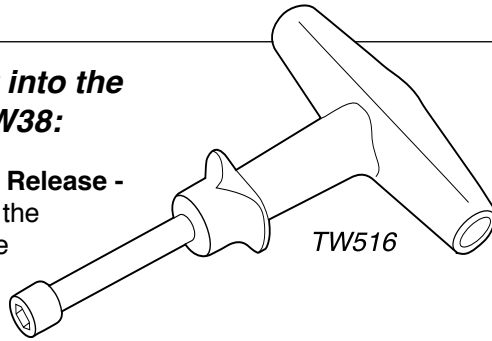

TW516

Ratchet Action - Fast tightening allows you to get a new "bite" without removing the wrench.

Reversing Collar - Loosen tight bolts with the same tool and with one hand. The safety design of the collar prevents overtightening.

Use: To loosen a bolt, align the flanges of the reversing collar with the handle. Then grasp the collar with two fingers, pulling the collar toward the handle. **Note:** Rotate the collar slightly counterclockwise to engage pin in slots. The collar locks the shaft to the handle and allows you to loosen the bolt. If you try to tighten a bolt, the collar will automatically disengage.

50319-409

Care of TW516 or TW38

With normal use, TW516 or TW38 should require no maintenance. The wrenches are lubricated for life during assembly. As long as the handle end washers are in place, the torque value cannot change. If the handle ends are damaged, the torque setting cannot be guaranteed.

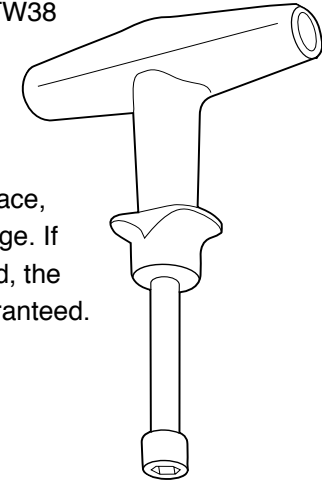

PIPE TOOLS & VISES
SINCE 1896

REED MANUFACTURING COMPANY

1425 WEST EIGHTH ST. ERIE, PA 16502 USA

PHONE: 800-666-3691 OR 814-452-3691

FAX: 800-456-1697 OR 814-455-1697

www.reedmfgco.com

50319-409