

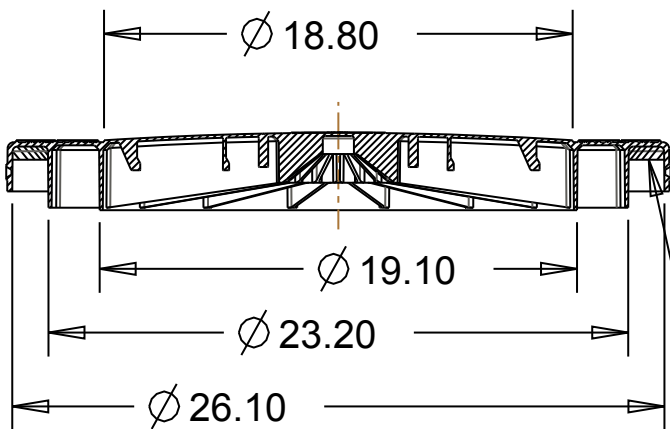

**DRAINAGE SOLUTIONS, INC**

(317) 346-4110

www.drainagesolutionsinc.com



SECTION A-A

PERMANENT FOAMED-IN POLYURETHANE GASKET

THIS AREA MAY BE FILLED WITH CONCRETE FOR ADDITIONAL WEIGHT

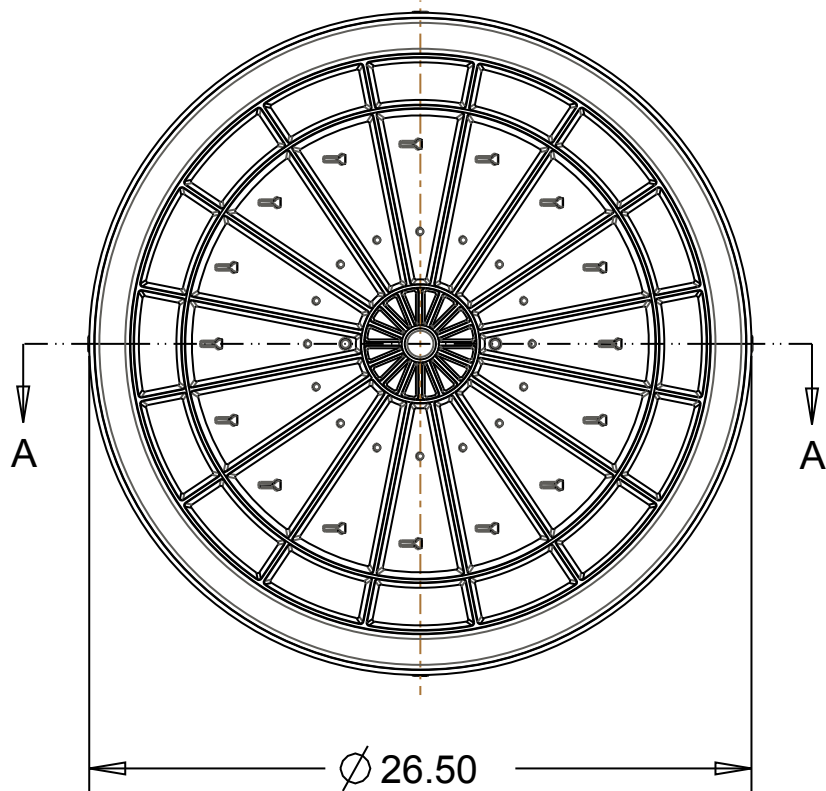
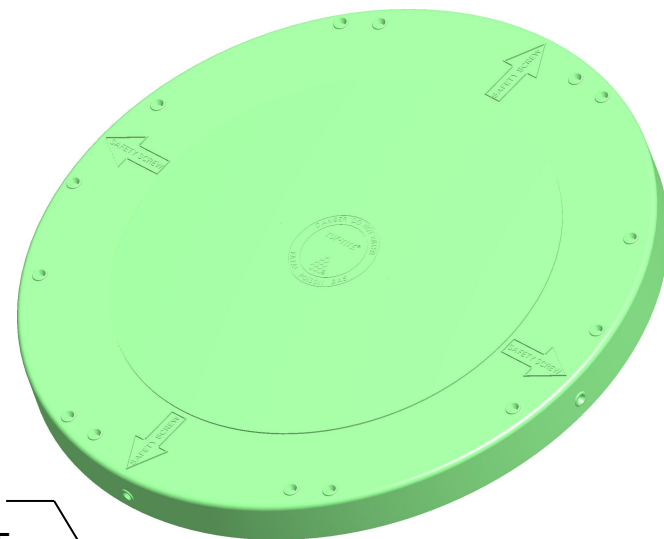

CONCRETE KEEPER<sup>TM</sup>  
RETAINING HOOKS

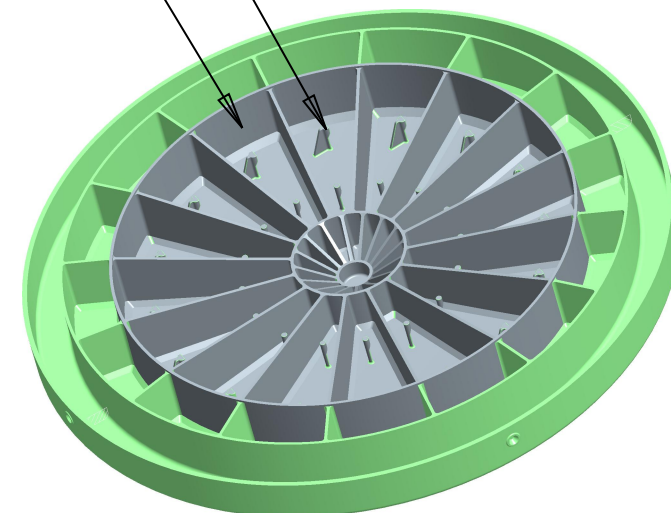

Material: Copolymer Polypropylene  
Color: Green



**Drainage and Septic Products**

(317) 346-4110

www.drainagesolutionsinc.com

PART NAME:

24" FLAT LID

PART #:

24 - FLAT