



# TUF-TITE®

## 6-Hole Distribution Box



### Tough Problem

Providing a simple, reliable, and permanent means for dividing septic tank effluent flow.

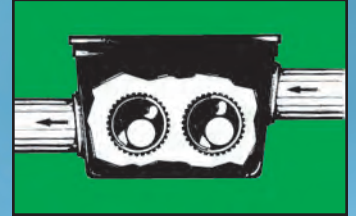

### TUF-TITE Solution

A strong, stable, permanent, non-corrosive Tuf-Tite Distribution Box, with a Tuf-Tite Speed Leveler in each outlet.

## Tuf-Tite® Distribution Box. THE TOUGH ONE!

- Injection molded HDPE
- Non-corrosive
- Simple to install
- Easy to level

In a septic environment, no other material can match High Density Polyethylene in delivering a lifetime of trouble-free service. Tuf-Tite Distribution Boxes are injection molded, using only premium HDPE which contains no fillers or foam.



### Snap-in pipe seals

They're patented. Simply insert your PVC pipe and push it through the flexible, polyethylene Tuf-Tite seal. Pipes fit watertight. Installation couldn't be easier.



### They're permanent

Unlike cement-based pipe grout, Tuf-Tite seals will not crack or corrode in septic conditions. They stay pliable and watertight permanently.

- Injection molded. Exceptionally strong.
- HDPE is non-corrosive in a septic environment.
- Patented snap-in pipe seals simplify installation.
- All Tuf-Tite products are U.V. stabilized.

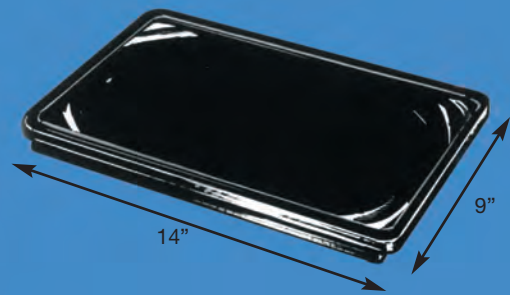
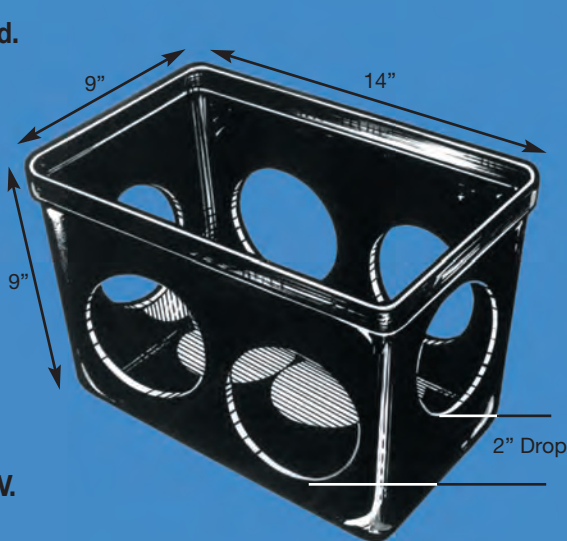

**Interlocking Lid.** Heavy-duty HDPE Lid is ribbed for added strength and rigidity. Slotted sides interlock on the Distribution Box to assure a tight fit.

The 6HD2 Distribution Box comes complete with a Regular Lid or an Inspection Port Lid, and 8 snap-in fittings of your choice.

## INSTALLATION IS JUST THIS SIMPLE

1. Position the Distribution Box on level virgin soil. **Do not place box on a concrete slab.**
2. Install the inlet pipe and outlet pipes. Be sure the bottoms of all pipes rest on virgin soil.
3. Level the Distribution Box and all pipes as needed.
4. Backfill the pipes to within two feet of the Distribution Box. Recheck the level of the box, then backfill up to the top lid ridge.
5. Install and adjust Tuf-Tite Speed Levelers.
6. Place lid on the Distribution Box and finish backfilling.

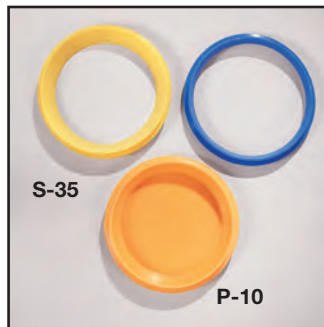

### Choice of Fittings

- S-35 Pipe Seal, for:  
Sewer and Drain
- SDR 35
  - ASTM 3034
  - Thin Wall
  - 1500 Lb. Crush
- P-10 Plug, for unused holes



### Choice of Lids

- Regular Lid.** Molded of rugged HDPE.
- Inspection Port Lid.** For easy access and inspection. Accepts 4" riser pipes.



### Tuf-Tite Speed Levelers™

Control the flow of effluent from the Distribution Box. Simply insert a Speed Leveler into each outlet pipe. Rotate each Speed Leveler so the flow is distributed as desired. Available for 3" or 4" PVC pipe.



*Water-tight Lids and Risers by Tuf-Tite®*

