

The only injection molded Trench Drain

- Non-corrosive High Density Polyethylene.
- 235 p.s.i industrial strength
- H-20 wheel load rating

Comes completely assembled. One unit. One price. No Extras.

Snap-on End Caps

Simply remove an end cap, extend the trench to any length, and re-install the end cap.

Cut to Size

The trench may be field cut with a hand saw, and capped with a male end cap or a TR1-D4 End Drain

Molded-In Ribs

Provide exceptional vertical compression strength - unequaled by other trench designs.

Choice of 3 Drains

Three bottom drains are molded in. Knock-out membranes allow trench to be drained with 2" or 3" Schedule 40, or 4" SDR35 pipe.

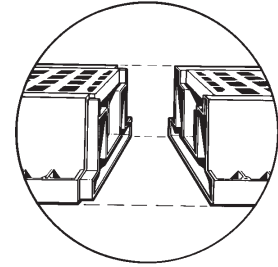
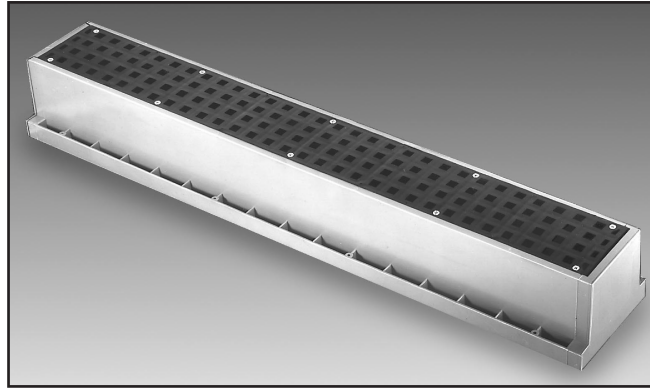

Interlocking Molded Ends

No need to remove the grate during installation. Simply snap the trenches together for a Tuf-Tite® free-flowing fit.

ADA Compliant Grate

Safe, square 1/2" x 1/2" openings. Molded of specially formulated HDPE with no foam or fillers.

Stainless Screws

The grate is held in place with 10 Type A-SmS screws.

Americans With Disabilities Act

Regulation 4.5.4: If gratings are located in walking surfaces, then they shall have spaces no greater than 1/2" (13mm) wide in one direction. If gratings have elongated openings, then they shall be placed so that the long dimension is perpendicular to the dominant direction of travel.

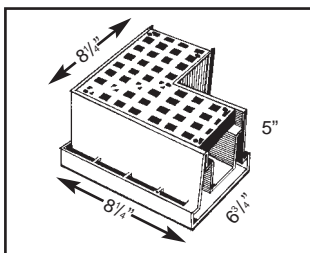
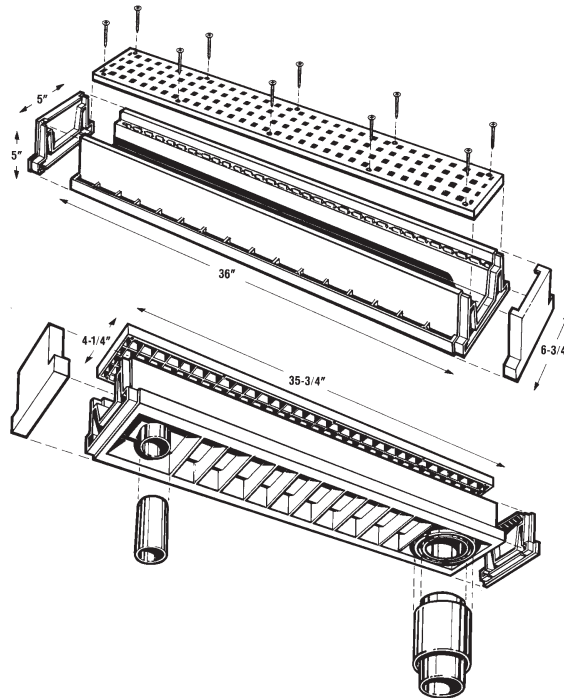

TR1-90 Corner

90° injection molded HDPE corner unit for Trench Drain. Molded interlocking ends for simple, snap-together installation. Comes assembled with grate and 6 Type A-SmS stainless screws. ADA compliant.

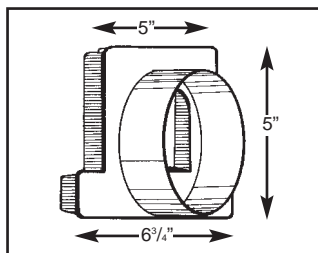

Optional End Drain TR1-D4

Male End Drain snaps on female end of Trench Drain. Accepts:

- 4" SDR35-3034 pipe
- 4" 2729 pipe
- 4" corrugated pipe when used with an MF-4 pipe connector

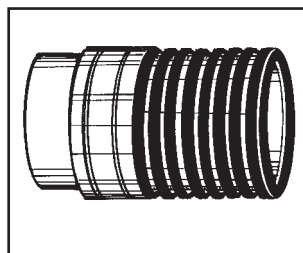

MF-4 Pipe Connector

To connect 4" corrugated pipe to the bottom of Trench Drain or to the End Drain TR1-D4. Provides a watertight fit.

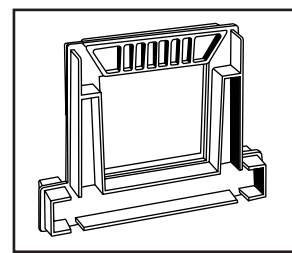

Gender Changer

Changes male end to female (TR1-GCF) or female end to male (TR1-GCM)

AD1 Area Drain with ADA Grate

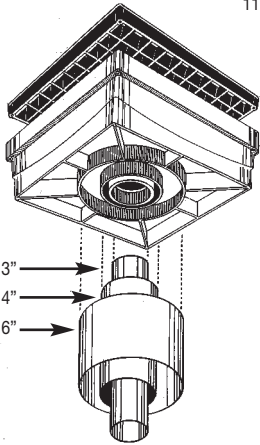
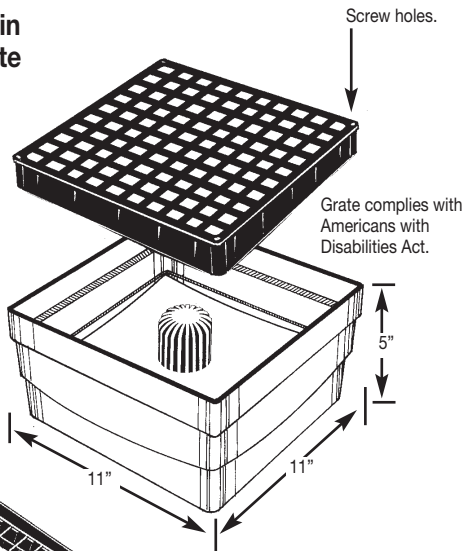

Choice of three size drain pipes.

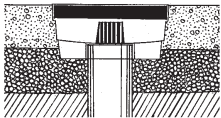

Installs easily inside and out.

- Rugged, Non-Corrosive**
 Molded of gray High-Density Polyethylene. Ribbed bottom provides exceptional compression strength.
- Atrium Drain**
 Drain hole is protected by a 1-3/4" high atrium screen. A build-up of small debris won't stop the flow.
- Steady Flow**
 The contoured bottom directs all water to the drain. Standing water is eliminated.
- Easily Installed - Anywhere!**
 Only 5" deep. Lightweight, easy to handle, and useable with 3", 4", or 6" pipe. No pipe fittings needed.
- Comes Complete**
 Price includes a heavy duty ADA compliant grate. No extras required.

2-Hole Drain Sumps

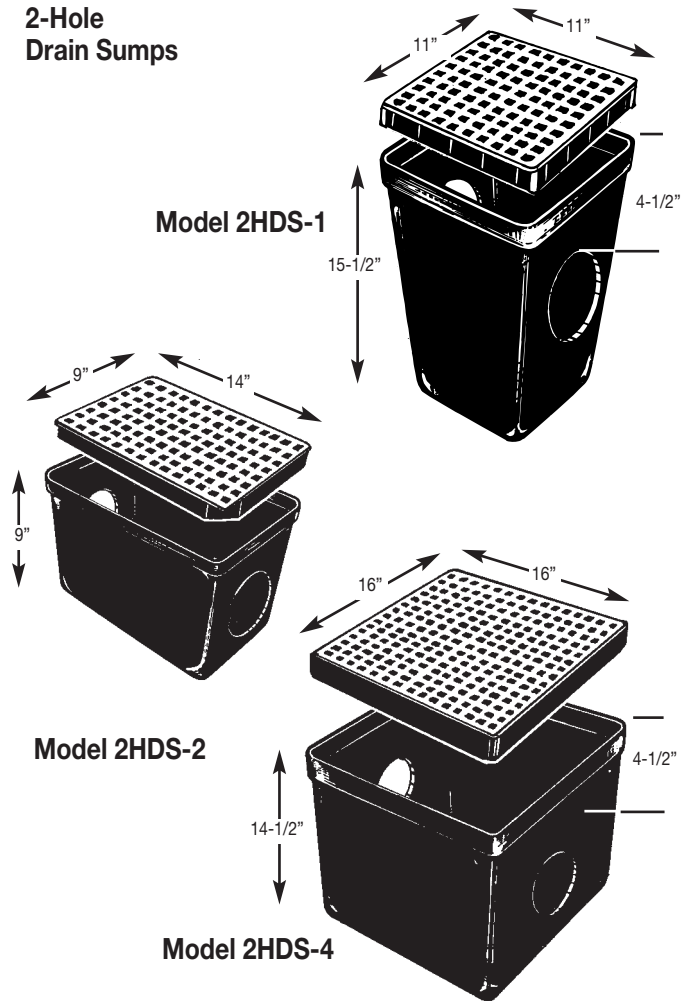

- All Tuf Tite® Drain Sumps are injection molded of non-corrosive High Density Polyethylene. Select 1, 2, 3, or 4-hole Drain Sump with molded HDPE grate and your choice of snap-in watertight fittings:
- S-35 Yellow Seal for Thin Wall Pipe
 - S-40 Blue Seal for Schedule 40 Pipe
 - P-10 Orange Plug for unused holes.

