

# SPECIFICATIONS - COMPACT BALL VALVES - Size: 1/2" to 4"



2-1/2" - 4"

1/2" - 2"

## SPECIFICATION OF MATERIAL

NO	PART	MATERIAL
1	BODY	UPVC, CPVC
2	STEM O-RING	EPDM, FPM(NBR)
3	STEM	UPVC, CPVC
4	BALL	UPVC, CPVC
5	SEAT SEAL	TPE, TPV, TPO
6	CAP	PVC, ABS
7	HANDLE	PVC, ABS
8	SCREW	SS304, STEEL

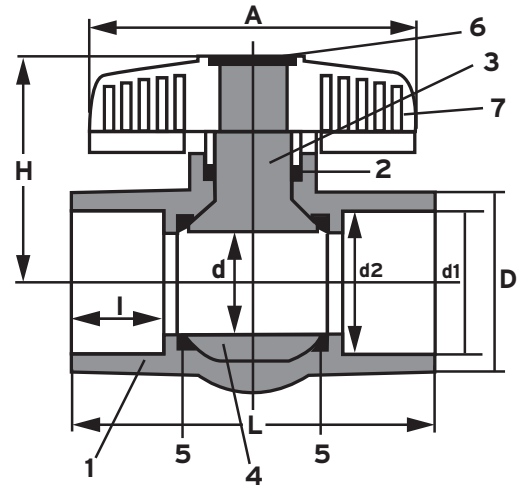
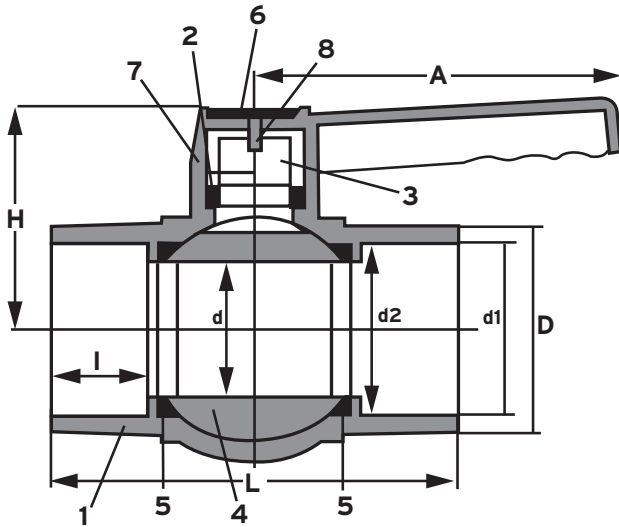

## ANSI SOCKET BALL VALVES

SIZE	I (min)	D1	D2	D	H	A	L	D
1/2"	0.688	0.848	0.836	0.591	1.457	2.677	3.031	1.181
3/4"	0.719	1.058	1.046	0.748	2.165	3.15	3.583	1.398
1"	0.895	1.325	1.31	0.945	2.598	3.701	4.055	1.693
1-1/4"	0.938	1.67	1.655	1.181	2.874	3.937	4.37	2.047
1-1/2"	1.094	1.912	1.894	1.339	3.189	4.331	4.843	2.441
2"	1.156	2.387	2.369	1.772	3.583	5.354	5.748	2.953
2-1/2"	1.75	2.889	2.868	2.165	3.898	6.693	7.008	3.583
3"	1.875	3.516	3.492	2.756	4.764	8.268	8.268	4.173
4"	2	4.518	4.491	3.346	5.276	9.291	10.039	5.118

## NPT THREADED BALL VALVES

SIZE	THREADS/IN	D	H	A	L	D
1/2"	14	0.591	1.457	2.677	3.031	1.181
3/4"	14	0.748	2.165	3.15	3.583	1.398
1"	11.5	0.945	2.598	3.701	4.055	1.693
1-1/4"	11.5	1.181	2.874	3.937	4.37	2.047
1-1/2"	11.5	1.339	3.189	4.331	4.843	2.441
2"	11.5	1.772	3.583	5.354	5.748	2.953
2-1/2"	8	2.165	3.898	6.693	7.008	3.583
3"	8	2.756	4.764	8.268	8.268	4.173
4"	8	3.346	5.276	9.291	10.039	5.118

(317) 346-4110  
www.drainagesolutionsinc.com

