



**DRAINAGE SOLUTIONS, INC**

(317) 346-4110

www.drainagesolutionsinc.com

REMOVABLE WATERTIGHT INSPECTION PORT, 10" OPENING

2" PVC ANTI-SIPHON PIPE ADAPTER

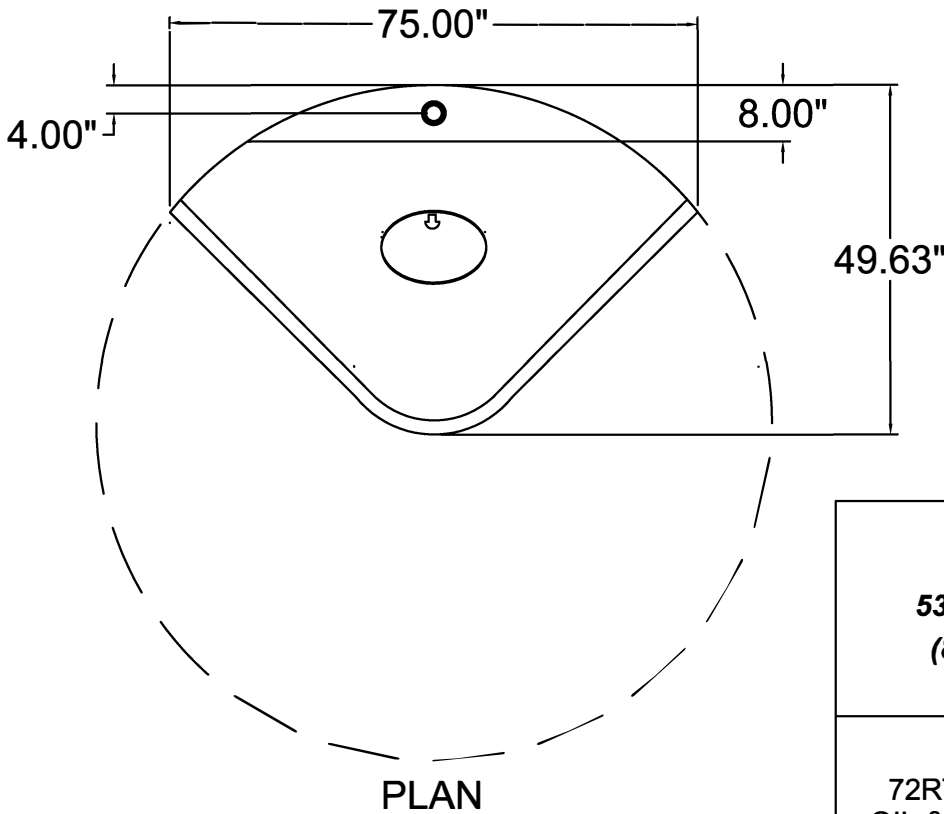
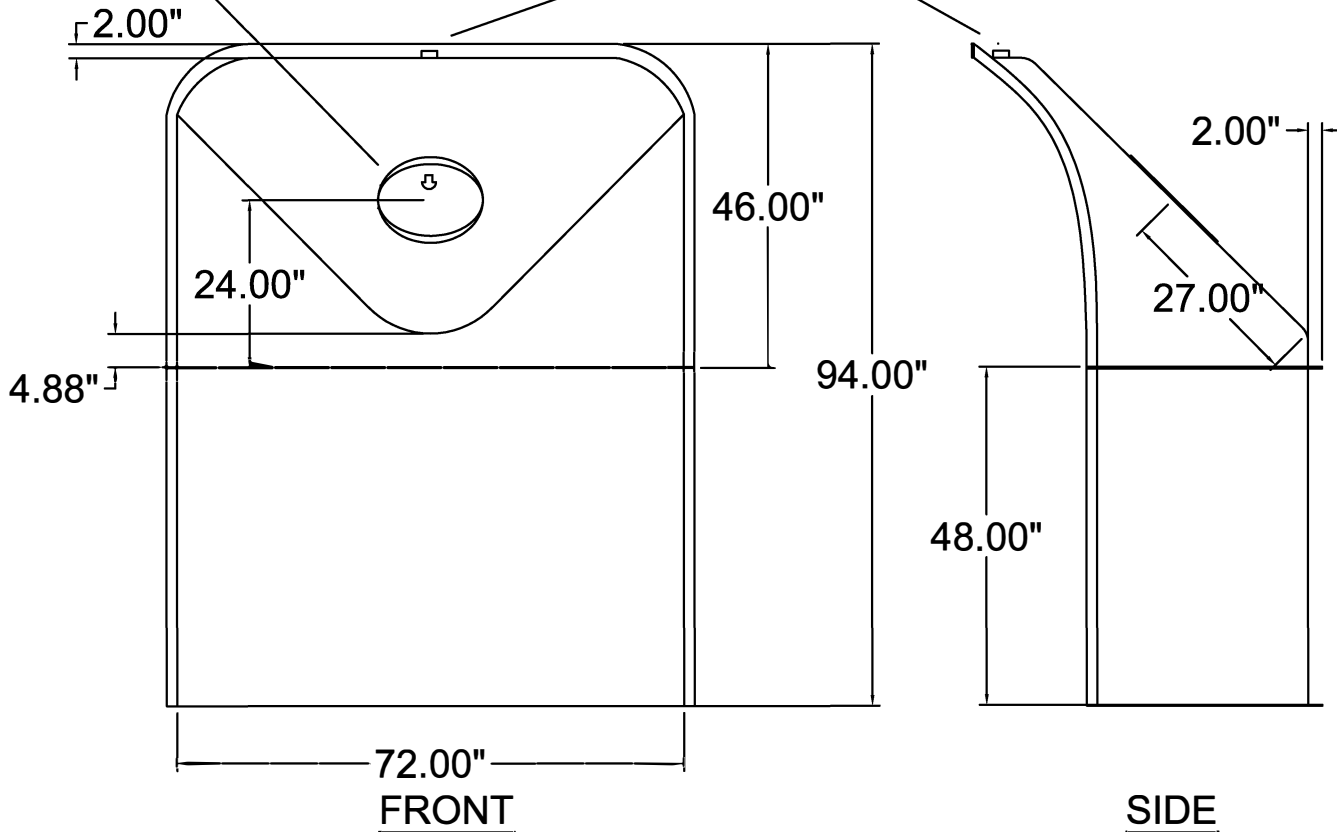

U.S. PATENT #6126817  
CANADA PATENT #2285146

<b>BMP, INC</b>		
53 MT. ARCHER RD., LYME CT 06371 (800) 504-8008 FAX: (877) 434-3197		
DESCRIPTION	DATE	SCALE
72RTB/96 SNOOT OIL & DEBRIS STOP	05/01/08	NONE
		DRAWING NUMBER
		72RTB/96

NOTE: FITS 96" ID STRUCTURE ONLY  
(MIN. SUMP DEPTH 2.5X OUTLET PIPE ID)