

REMOVABLE WATERTIGHT
INSPECTION PORT, 10" OPENING

2" PVC ANTI-SIPHON
PIPE ADAPTER

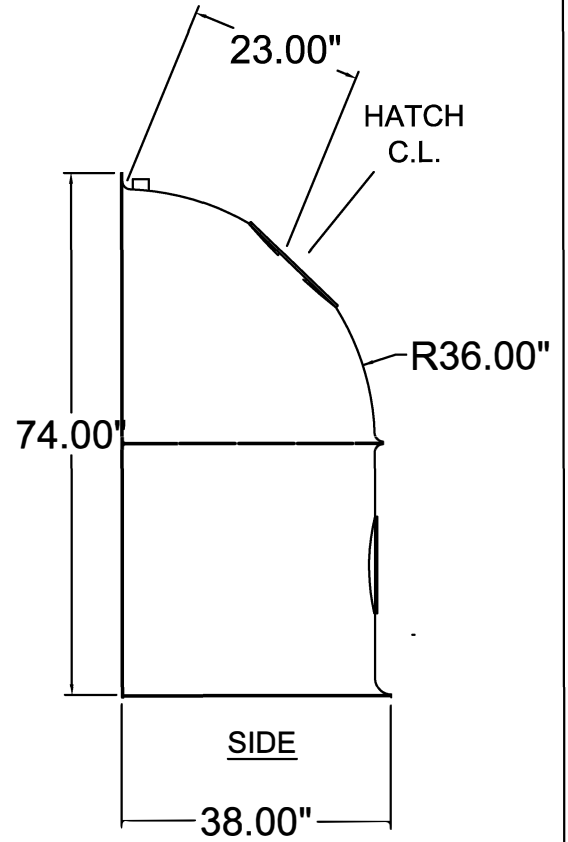

BOSS FOR
OPTIONAL
HATCHES

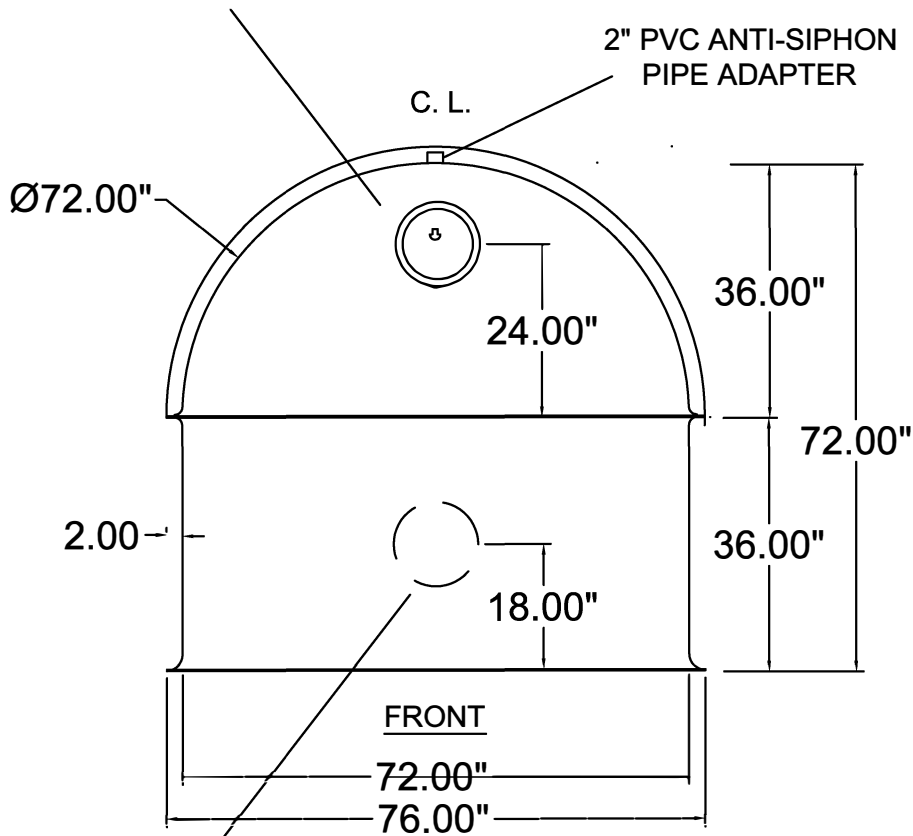
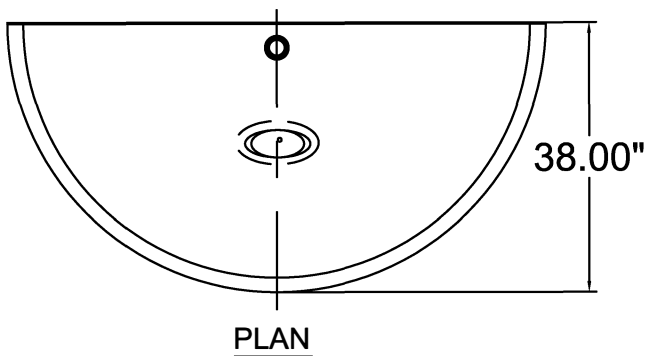

U.S. PATENT #6126817
CANADA PATENT #2285146

BMP, INC



(317) 346-4110
www.drainagesolutionsinc.com

BMP, INC		
DESCRIPTION	DATE	SCALE
72FTB SNOOT OIL & DEBRIS STOP (TOP & 2 BASES)	09/01/05	NONE
DRAWING NUMBER		
72FTB		