

REMOVABLE WATERTIGHT
INSPECTION PORT, 10" OPENING

2" PVC ANTI-SIPHON
PIPE ADAPTER

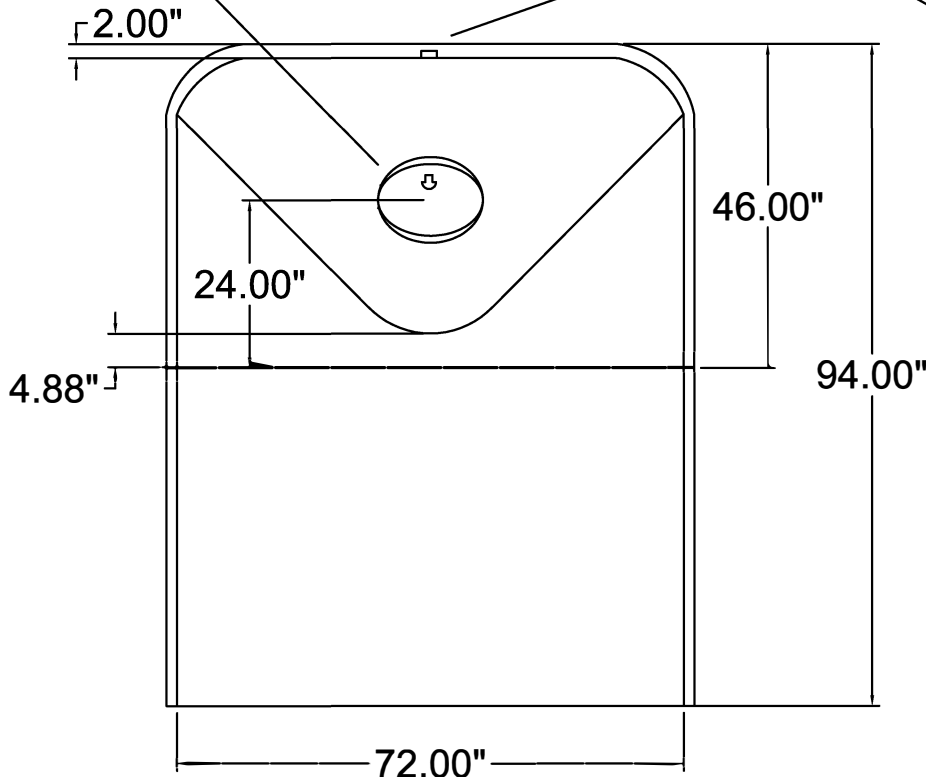

72.00"
FRONT

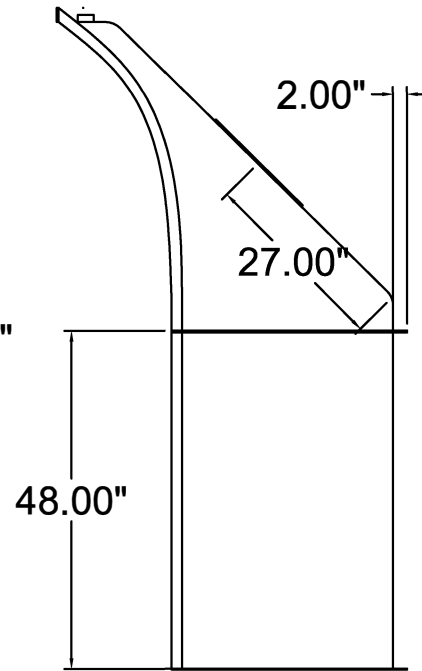

SIDE

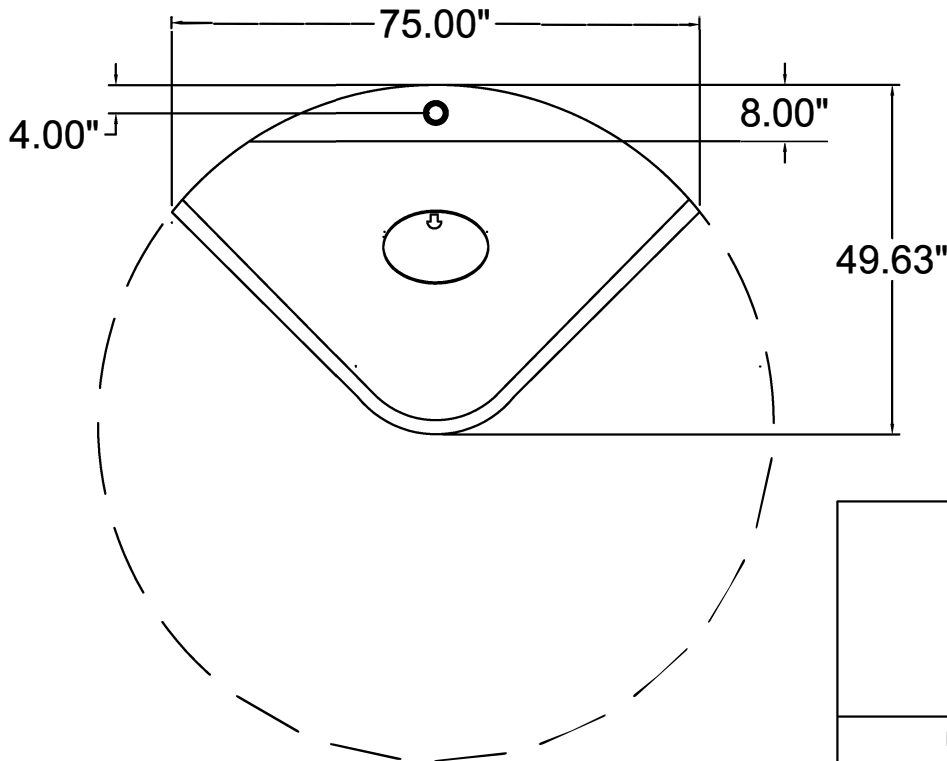

PLAN

NOTE: FITS 96" ID STRUCTURE ONLY
(MIN. SUMP DEPTH 2.5X OUTLET PIPE ID)



(317) 346-4110

www.drainagesolutionsinc.com

U.S. PATENT #6126817
CANADA PATENT #2285146

BMP, INC

DESCRIPTION	DATE	SCALE
72RTB/96 SNOOT OIL & DEBRIS STOP	05/01/08	NONE
DRAWING NUMBER		
72RTB/96		