

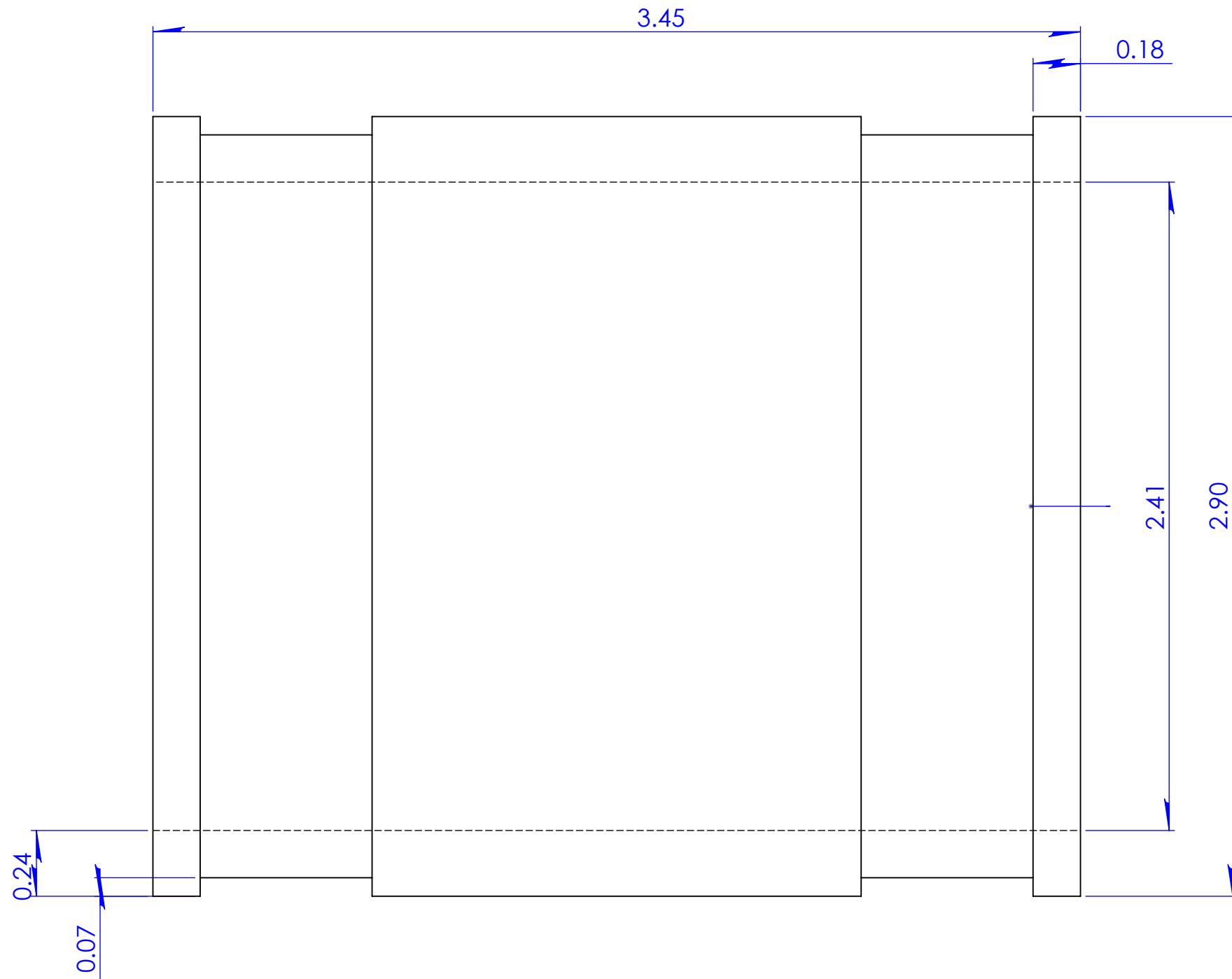

(317) 346-4110
www.drainagesolutionsinc.com

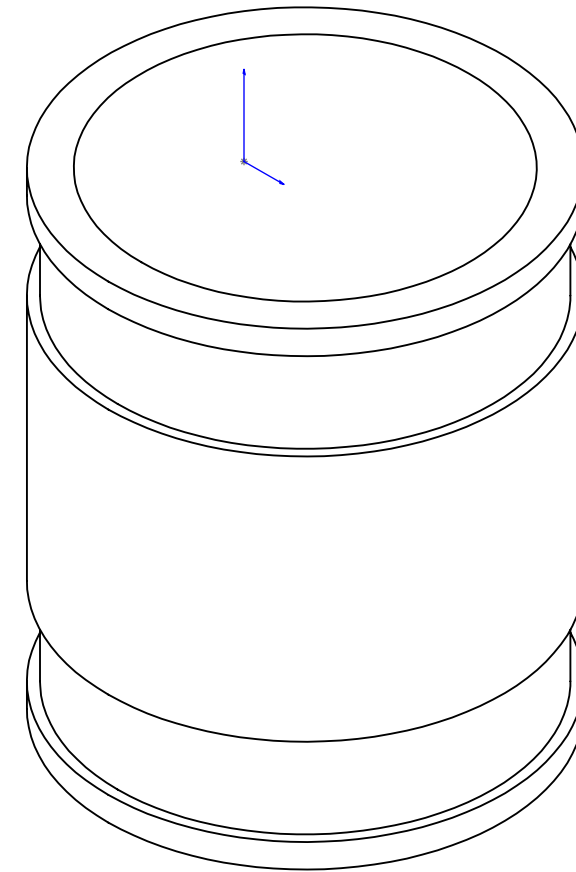

***Part Includes:**

- Clamp: Part Number 042-300, 2 pcs.
- Shear Ring: Part Number SRC-11, 1 pc.
- See additional drawings for these parts.



300 S. DAYTON ST.
DAVISON, MI 48423
PH: 810-653-9626
FAX: 810-654-2616

Part Weight	0.57 lbs.
Min/Max Temp.	-30/140 Degrees F
Pressure Tested	4.3 PSI
Material	Flexible PVC 60 Duro Shore A
Installation Torque	60" Lbs.
Conforms to ASTM	D5926, C1173
Box Quantity	
Clamps used	300 Series

TOLERANCES:
.X= Fractional ±
.XX= ±.060
.XXX= ±.032
ANG.= ±0.5°
UNLESS OTHERWISE SPECIFIED

DESCRIPTION: Coupling 2" Cast Iron/Plastic x 2" Cast Iron/Plastic

1056-22RC

PROPRIETARY AND CONFIDENTIAL
THE INFORMATION CONTAINED IN THIS DRAWING IS THE SOLE PROPERTY OF FERNCO, INC. ANY REPRODUCTION IN PART OR AS A WHOLE WITHOUT THE WRITTEN PERMISSION OF FERNCO, INC. IS PROHIBITED.

UNITS: INCHES	SIZE A	DESIGNER: D. Brady	SCALE not to scale
3RD ANGLE PROJECTION DO NOT SCALE DRAWING		CHECKER:	DATE: 8/19/2008
			SHEET 1 OF 1