

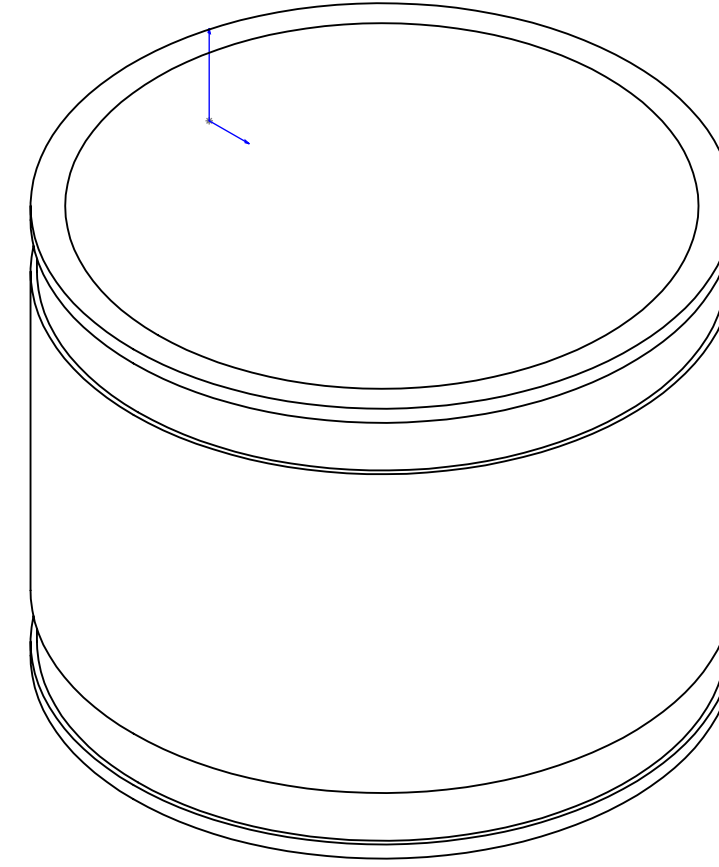

(317) 346-4110
www.drainagesolutionsinc.com

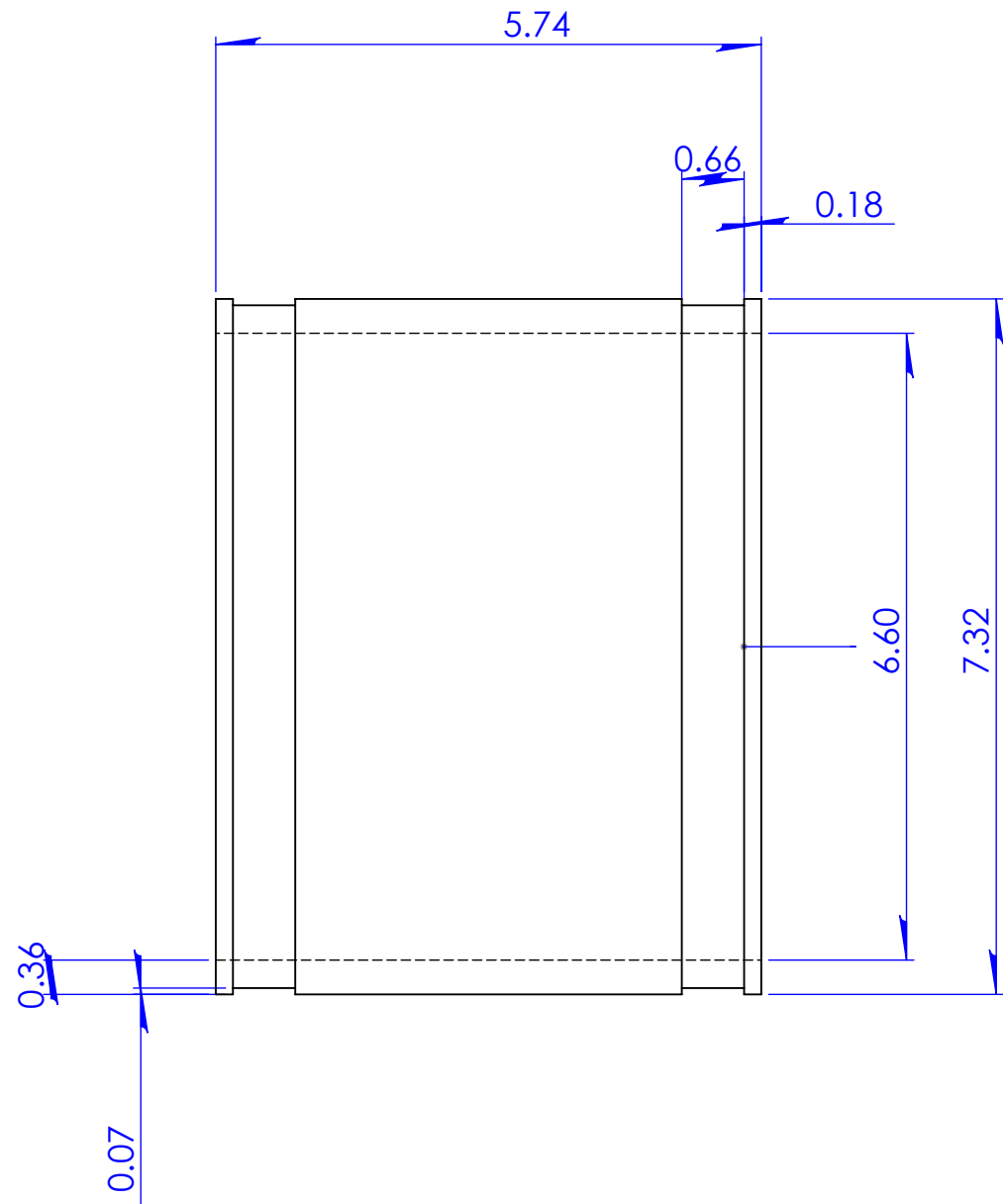

- *Part Includes:
- Clamp: Part Number 116-300, 2 pcs.
 - Shear Ring: Part Number SRC-25, 1 pc.
 - See additional drawings for these parts.



300 S. DAYTON ST.
DAVISON, MI 48423
PH: 810-653-9626
FAX: 810-654-2616

Part Weight	2.88 lbs.
Min/Max Temp.	-30/140 Degrees F
Pressure Tested	4.3 PSI
Material	Flexible PVC 60 Duro Shore A
Installation Torque	60" Lbs.
Conforms to ASTM	D5926, C1173
Box Quantity	
Clamps used	300 Series

TOLERANCES:
.X= Fractional ±
.XX= ±.060
.XXX= ±.032
ANG.= ±0.5°
UNLESS OTHERWISE SPECIFIED

UNITS: INCHES
SIZE: **A**
3RD ANGLE PROJECTION
DO NOT SCALE DRAWING

DESCRIPTION:	Coupling 6" Cast Iron/Plastic x 6" Cast Iron/Plastic	
	1056-66RC	
DESIGNER:	D. Brady	SCALE: not to scale
CHECKER:	DATE: 8/19/2008	SHEET 1 OF 1

PROPRIETARY AND CONFIDENTIAL
THE INFORMATION CONTAINED IN THIS DRAWING IS THE SOLE PROPERTY OF FERNCO, INC. ANY REPRODUCTION IN PART OR AS A WHOLE WITHOUT THE WRITTEN PERMISSION OF FERNCO, INC. IS PROHIBITED.