

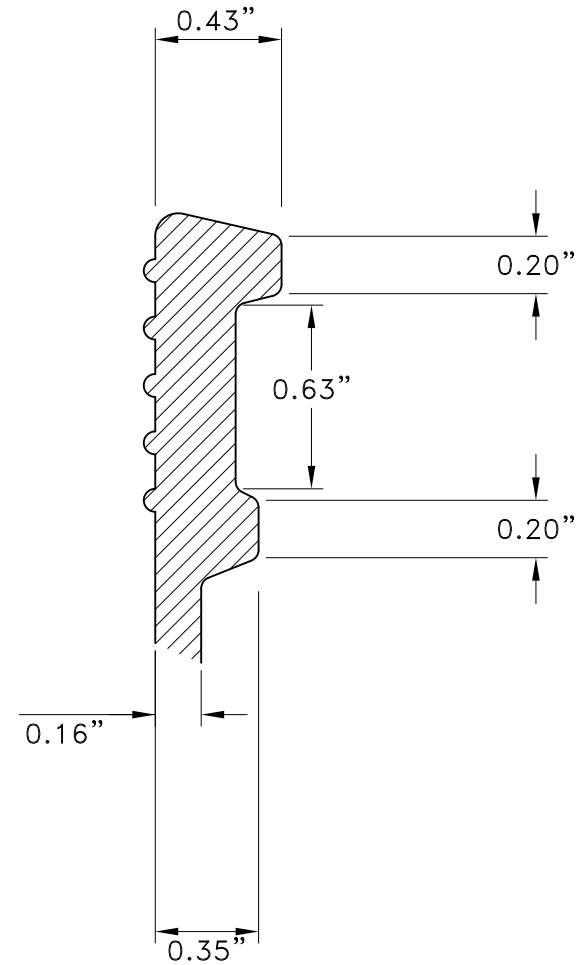

DRAINAGE SOLUTIONS, INC (317) 346-4110
www.drainagesolutionsinc.com

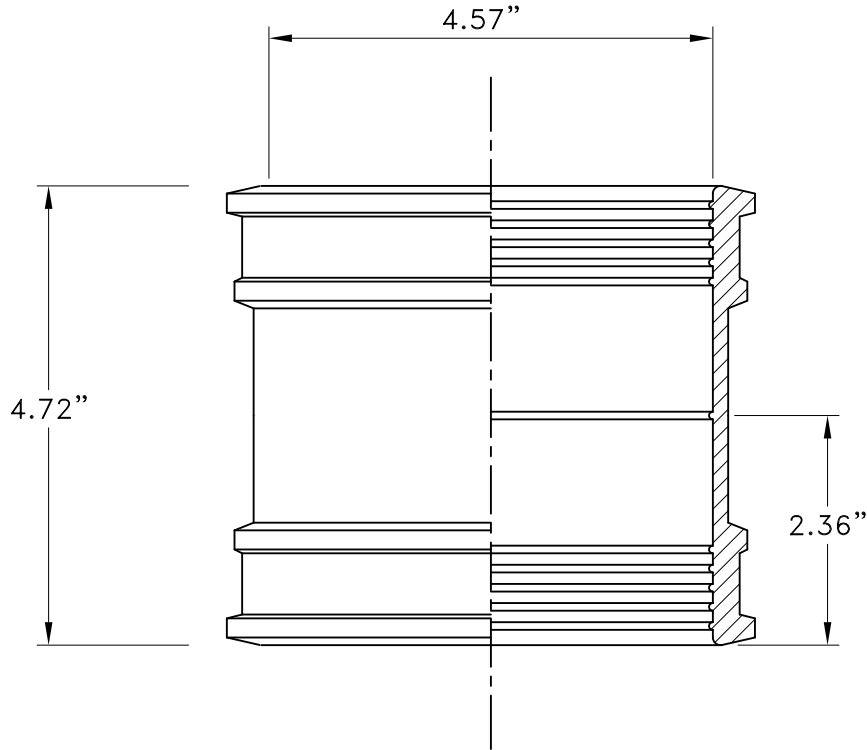

NOTES:
MATERIAL: 60IRHD ELASTOMER TO FERNCO SPECIFICATION
TOLERANCES: TO ISO 3302:PART 1:1996 CLASS M3 UNLESS STATED
DIMENSIONS: ALL INCHES UNLESS STATED
INCLUDES: 316SS SHIELD & CLAMPS
INSTALLATION: TORQUE TO 60 in-lb

Part No: CC115G
Description: 3" DI/DU
CHEMICAL COUPLING

Revised By: PJS
Date: 05/22/2017



Fernco Inc.
Davison, MI.
Tel: (810) 503-9000
www.fernco.com

NOT TO SCALE