

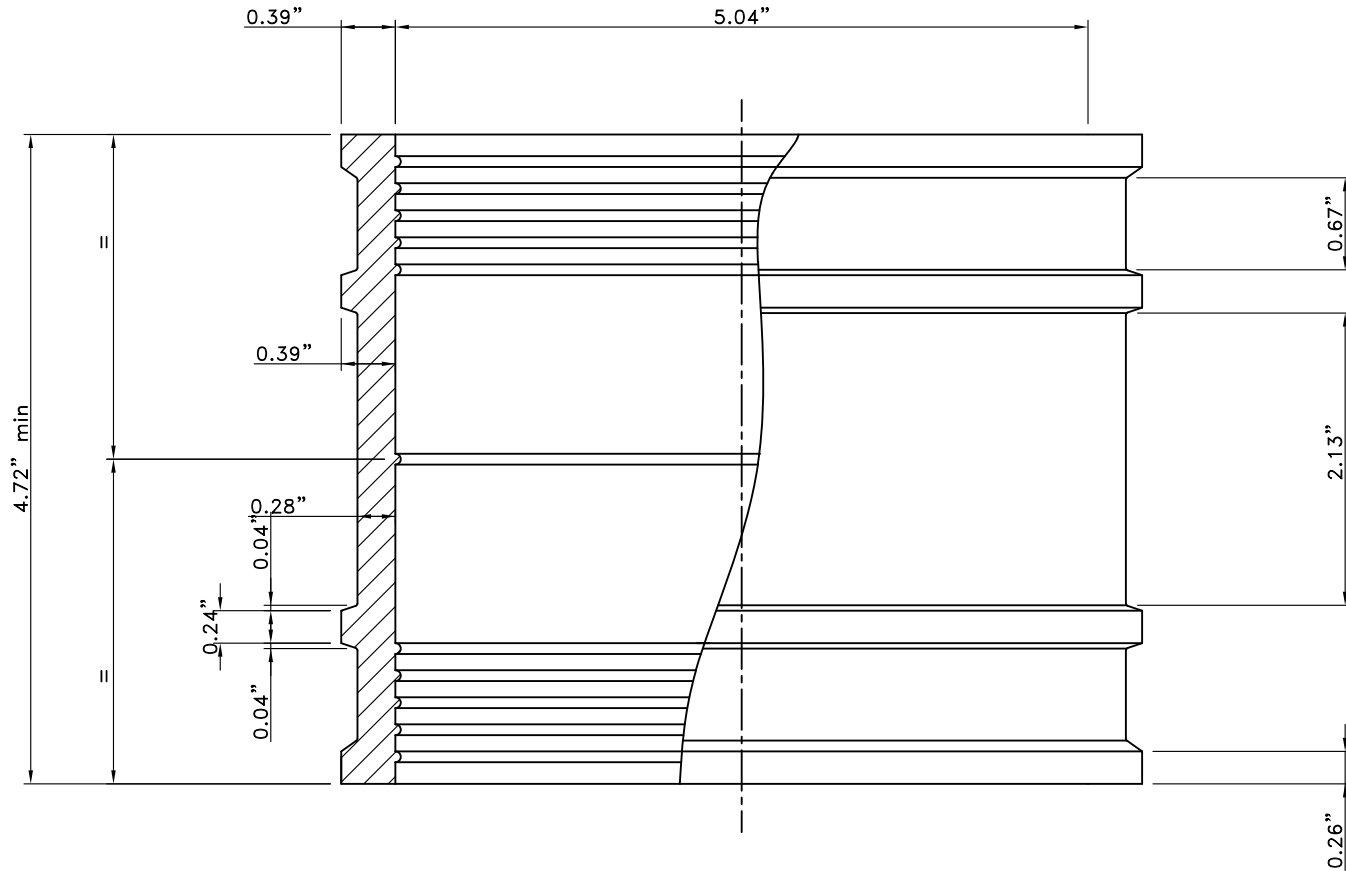

(317) 346-4110

DRAINAGE SOLUTIONS, INC www.drainagesolutionsinc.com



NOTES:
MATERIAL: 60IRHD ELASTOMER TO FERNCO SPECIFICATION
TOLERANCES: TO ISO 3302:PART 1:1996 CLASS M3 UNLESS STATED
DIMENSIONS: ALL INCHES UNLESS STATED
INCLUDES: 316SS SHIELD & CLAMPS
CHEMICAL RESISTANT FEP SLEEVES & PTFE SEALS
INSTALLATION: TORQUE TO 60 in-lb

Part No: CC125G
Description: 4" PL/CI/GL/DU/DI
CHEMICAL COUPLING

Revised By: PJS
Date: 05/08/2017



Fernco Inc.
Davison MI.
Tel: (810) 503-9000
www.fernco.com

NOT TO SCALE