

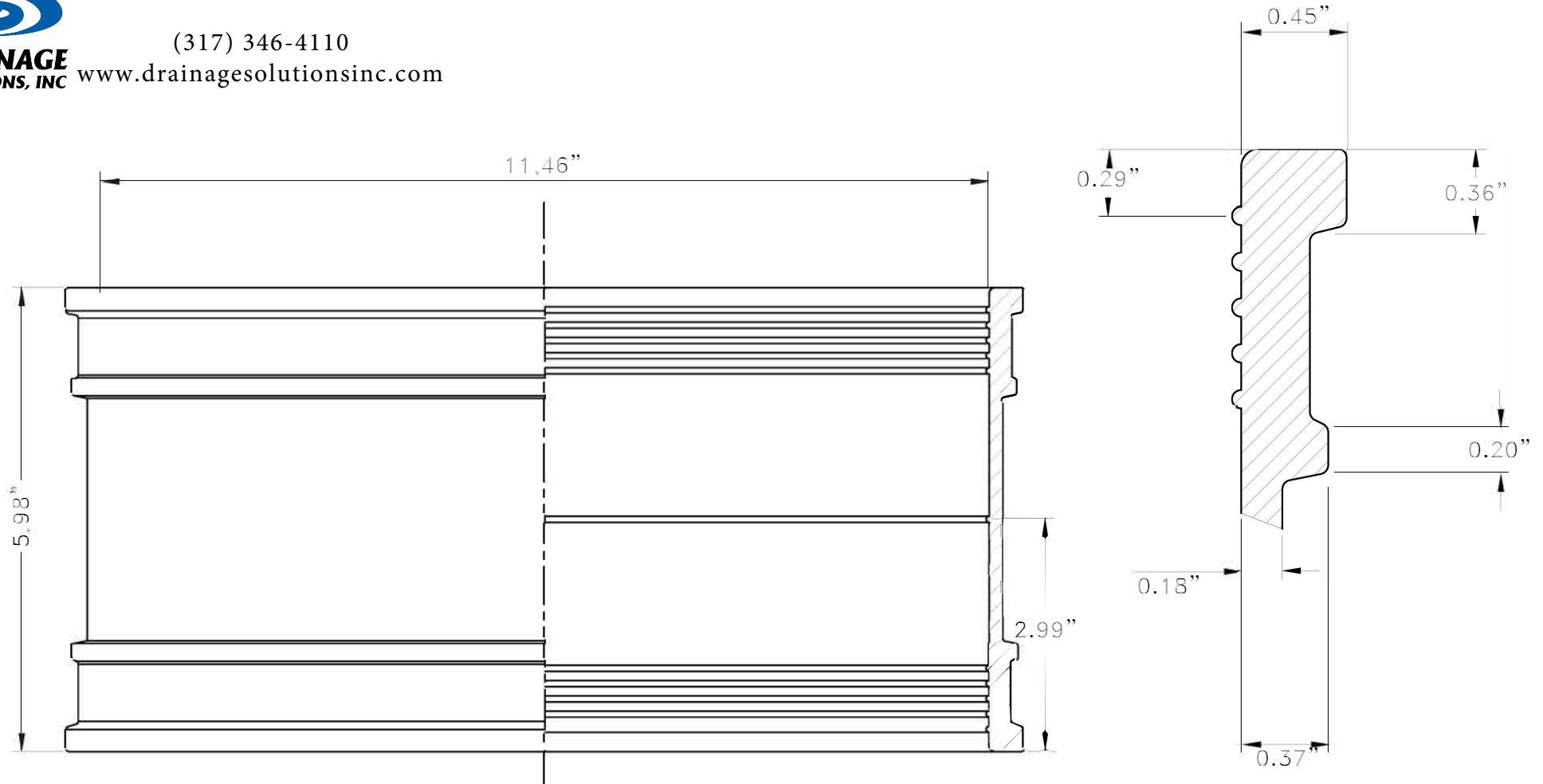

**DRAINAGE SOLUTIONS, INC** (317) 346-4110  
www.drainagesolutionsinc.com



**NOTES:**

MATERIAL: 60IRHD ELASTOMER TO FERNCO SPECIFICATION  
TOLERANCES: TO ISO 3302:PART 1:1996 CLASS M3 UNLESS STATED  
DIMENSIONS: ALL INCHES UNLESS STATED  
INCLUDES: 316SS SHIELD & CLAMPS  
CHEMICAL RESISTANT FEP SLEEVES & PTFE SEALS  
INSTALLATION: TORQUE TO 60 in-lb

Part No: CC290G  
Description: 10" PL/DU/DI  
CHEMICAL COUPLING

Revised By: PJS  
Date: 5/30/2017



Fernco Inc.  
Davison, MI.  
Tel: (810) 503-9000  
www.fernco.com

NOT TO SCALE