

.040 Height

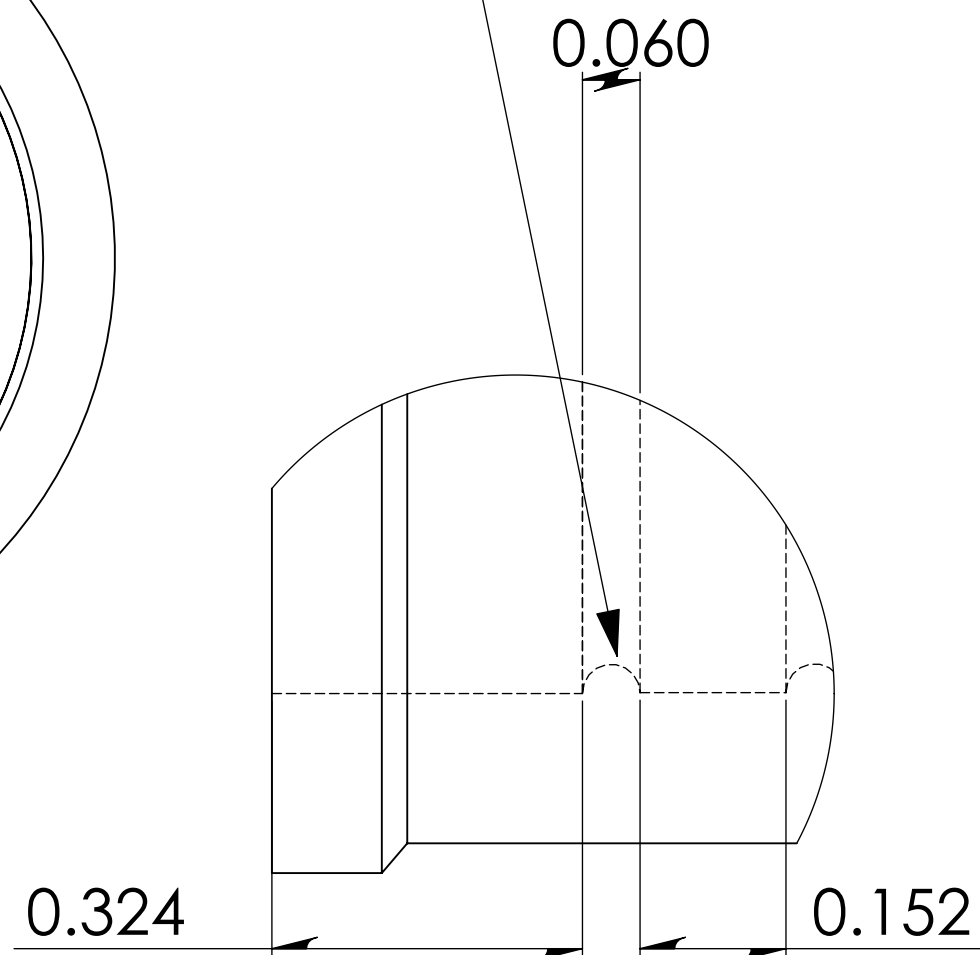

DETAIL A  
SCALE 5 : 1

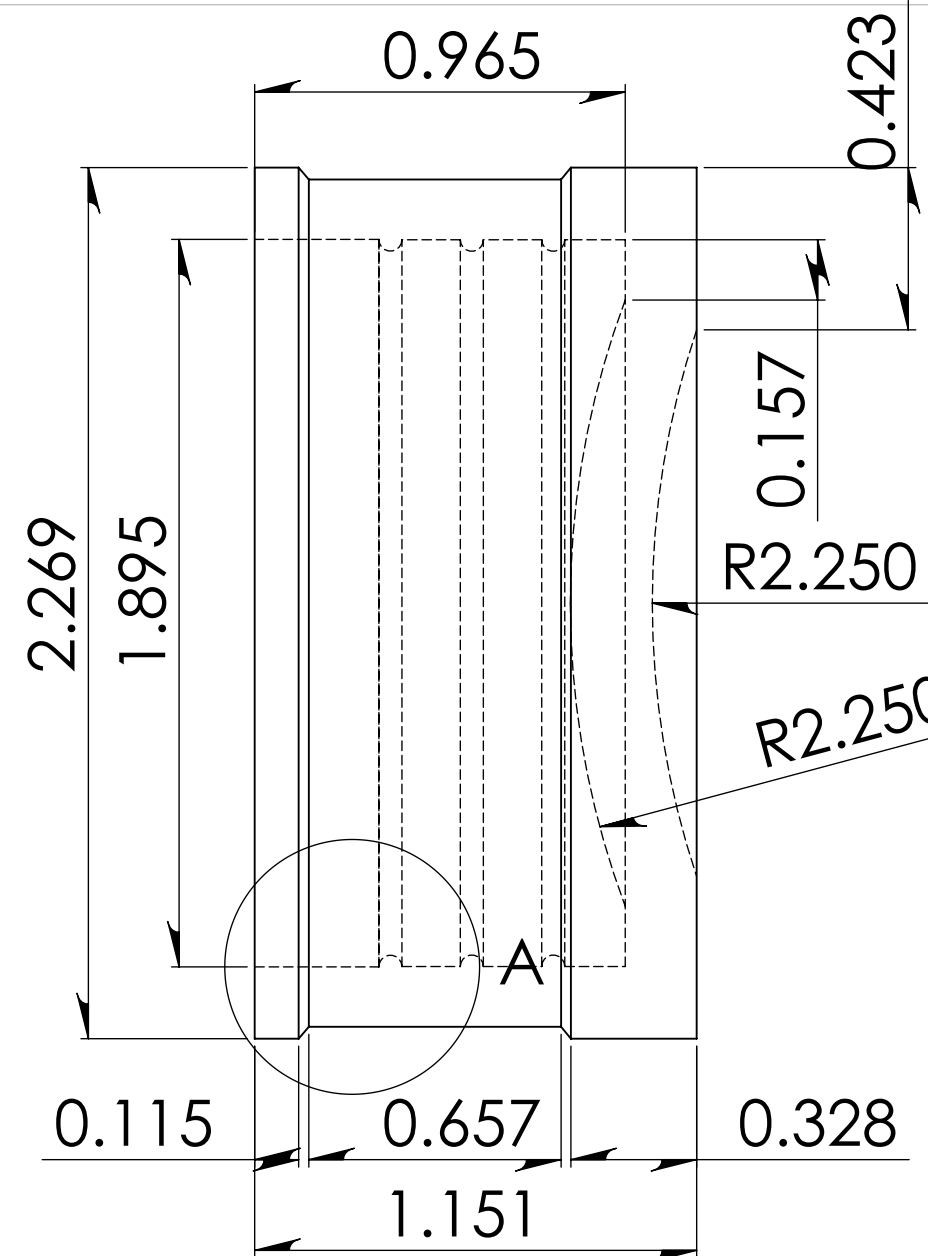

(317) 346-4110  
www.drainagesolutionsinc.com

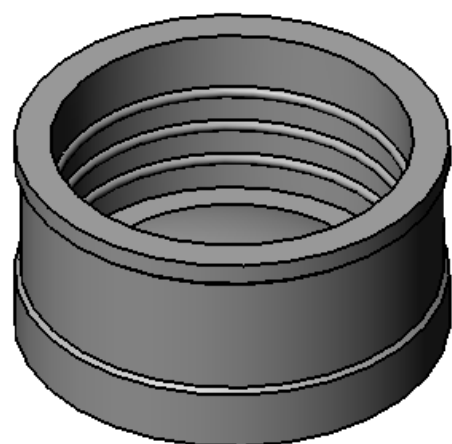

**NOTES:**  
- SOME HIDDEN LINES NOT SHOWN  
- BREAK ALL SHARP CORNERS  
- REPORT ALL CHANGES TO ENGINEERING

**PROPRIETARY AND CONFIDENTIAL**  
THE INFORMATION CONTAINED IN THIS DRAWING IS THE SOLE PROPERTY OF FERNCO, INC. ANY REPRODUCTION IN PART OR AS A WHOLE WITHOUT THE WRITTEN PERMISSION OF FERNCO, INC. IS PROHIBITED.

Part Weight	
Min/Max Temp.	-30/140 Degrees F
Pressure Tested	4.3 PSI
Material	Flexible PVC
Installation Torque	60" Lbs.
Conforms to ASTM	D5926
Box Quantity	40
Clamps used	300 Series



300 S. DAYTON ST.  
DAVISON, MI 48423  
PH: 810-653-9626  
FAX: 810-654-2616

<b>TOLERANCES:</b> .X= Fractional ± .XX= ±.02 .XXX= ±.030 ANG.= ±0.5° UNLESS OTHERWISE SPECIFIED		DESCRIPTION: Cap 1 1/2" Plastic Pipe  QC-101	
UNITS: INCHES	SIZE: <b>A</b>	DESIGNER: D. Brady	SCALE: not to scale
3RD ANGLE PROJECTION DO NOT SCALE DRAWING		CHECKER: DATE: 8/3/2007	SHEET 1 OF 1