

DETAIL A
SCALE 2.5 : 1

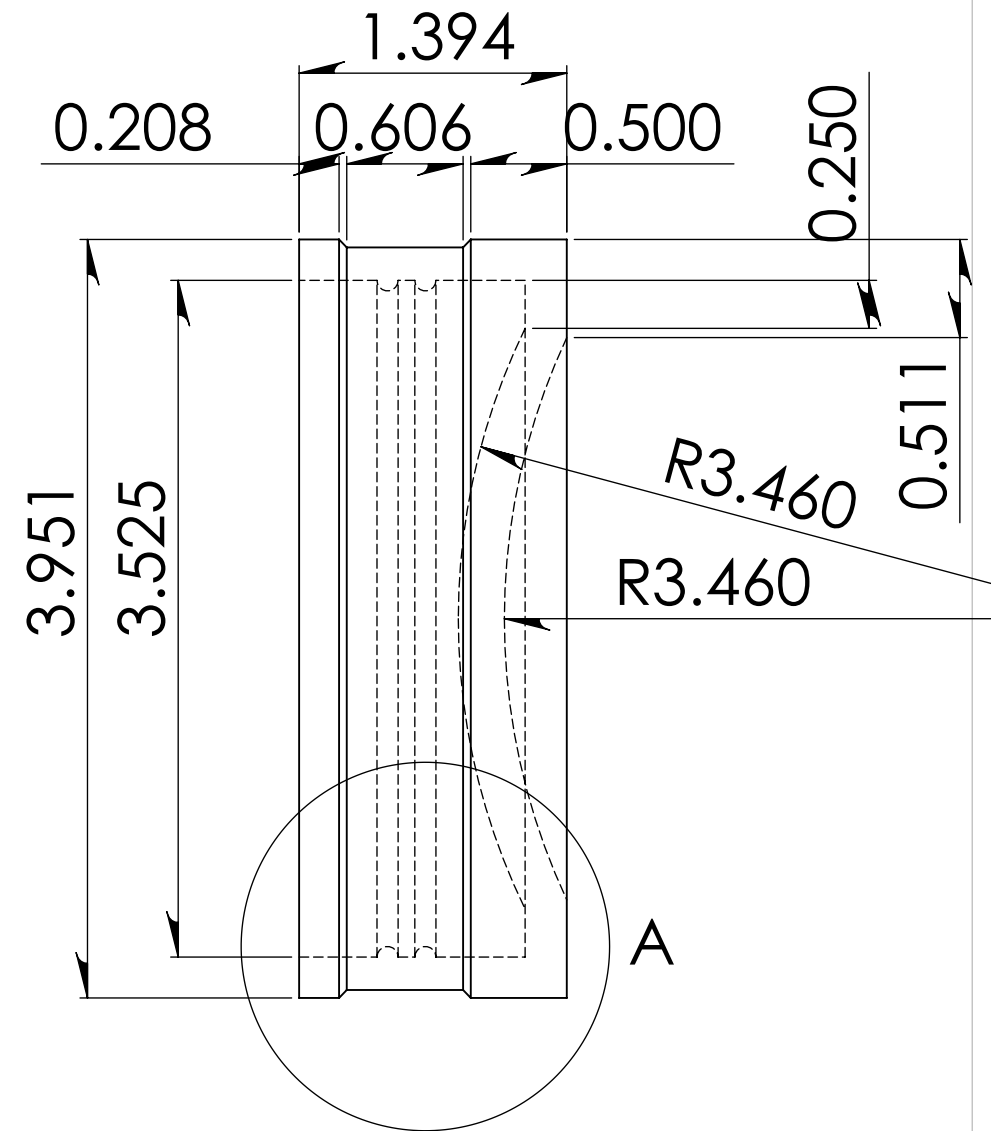

DRAINAGE SOLUTIONS, INC

(317) 346-4110
www.drainagesolutionsinc.com

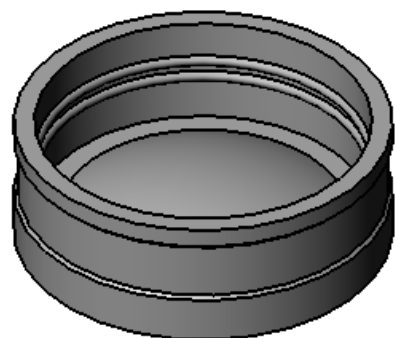

NOTES:
- SOME HIDDEN LINES NOT SHOWN
- BREAK ALL SHARP CORNERS
- REPORT ALL CHANGES TO ENGINEERING

PROPRIETARY AND CONFIDENTIAL
THE INFORMATION CONTAINED IN THIS DRAWING IS THE SOLE PROPERTY OF FERNCO, INC. ANY REPRODUCTION IN PART OR AS A WHOLE WITHOUT THE WRITTEN PERMISSION OF FERNCO, INC. IS PROHIBITED.

Part Weight	
Min/Max Temp.	-30/140 Degrees F
Pressure Tested	4.3 PSI
Material	Flexible PVC
Installation Torque	60" Lbs.
Conforms to ASTM	D5926
Box Quantity	40
Clamps used	300 Series



300 S. DAYTON ST.
DAVISON, MI 48423
PH: 810-653-9626
FAX: 810-654-2616

TOLERANCES: .X= Fractional ± .XX= ±.02 .XXX= ±.030 ANG.= ±0.5° UNLESS OTHERWISE SPECIFIED		DESCRIPTION: Cap 3" Plastic QC-103	
UNITS: INCHES	SIZE: A	DESIGNER: D. Brady	SCALE: not to scale
3RD ANGLE PROJECTION DO NOT SCALE DRAWING		CHECKER:	DATE: 8/3/2007
			SHEET 1 OF 1