



300 S. DAYTON ST.  
 DAVISON, MI 48423  
 PH: 810-653-9626  
 FAX: 810-654-2616

QC-105

DESCRIPTION: Cap 5" PVC



**DRAINAGE  
 SOLUTIONS, INC**

(317) 346-4110  
 www.drainagesolutionsinc.com

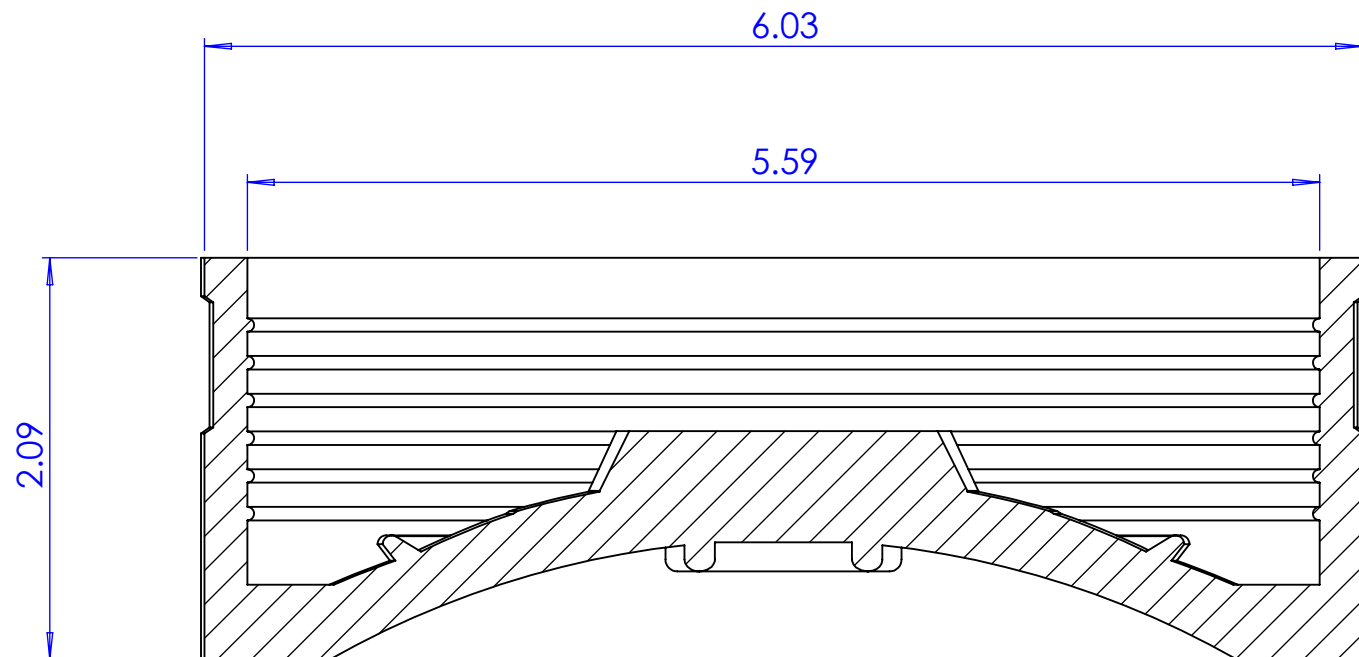
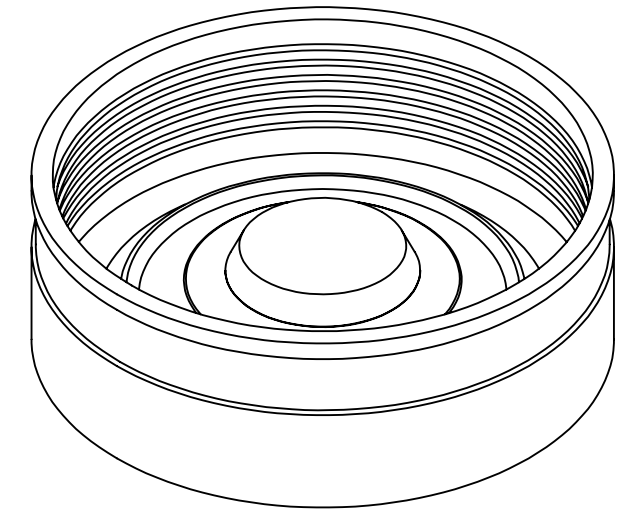

**SECTION C-C**  
 SCALE 1 : 1

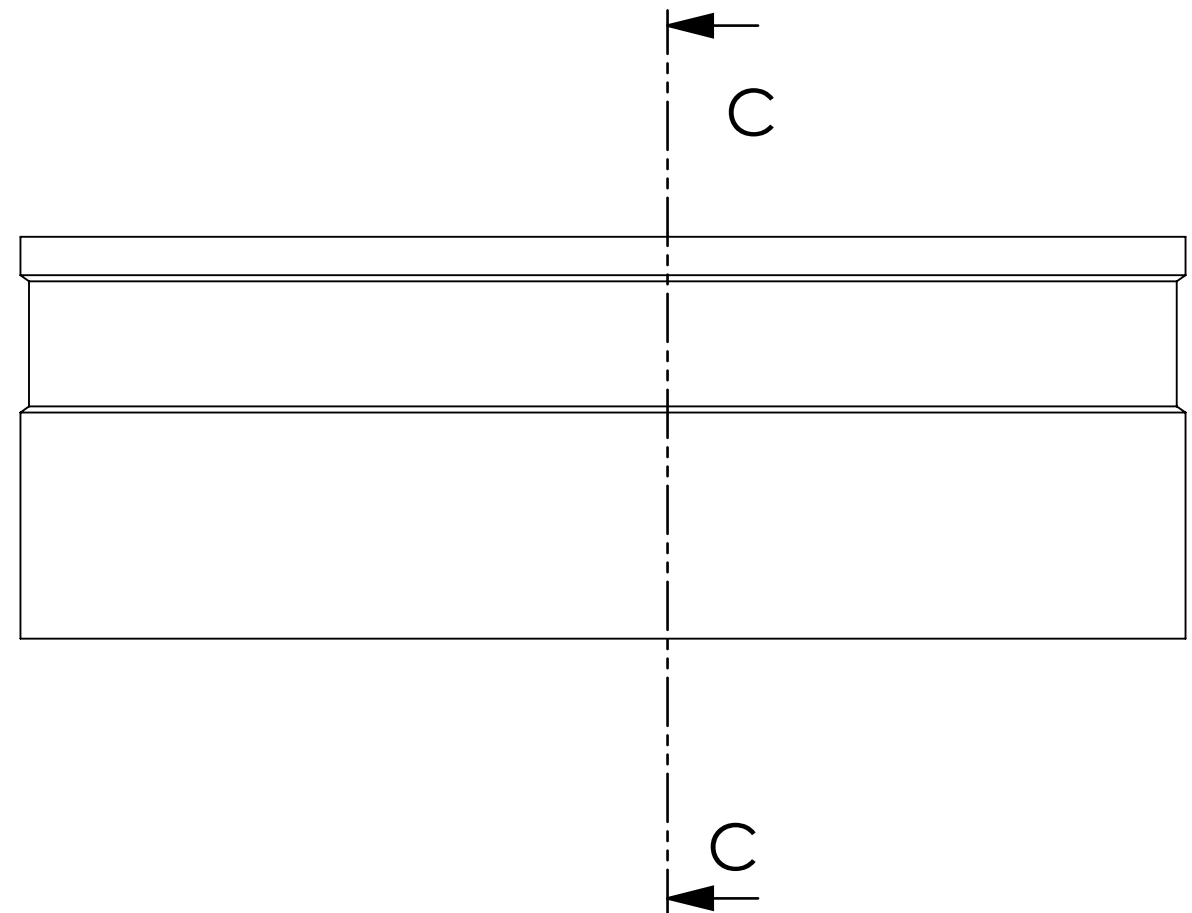

PROPRIETARY AND CONFIDENTIAL  
 THE INFORMATION CONTAINED IN THIS  
 DRAWING IS THE SOLE PROPERTY OF  
 FERNCO, INC. ANY REPRODUCTION IN  
 PART OR AS A WHOLE WITHOUT THE  
 WRITTEN PERMISSION OF FERNCO, INC.  
 IS PROHIBITED.

**TOLERANCES:**  
 .X= Fractional ±  
 .XX= ±.06  
 ANG.= +3°  
 UNLESS OTHERWISE SPECIFIED

Part Weight	1.00 lbs.	Installation Torque	60" Lbs.
Min/Max Temp.	-30/140 Degrees F	Conforms to ASTM	D5926, C1173
Pressure Tested	4.3 PSI	Clamps used	300 Series Stainless
Material	Flexible PVC 60 Duro Shore A	Box Quantity	

UNITS:	INCHES
SIZE:	<b>A</b>
3RD ANGLE PROJECTION	
DO NOT SCALE DRAWING	

DESIGNER:	D. Brady
CHECKER:	
DATE:	9/13/2012

SCALE:	not to scale
SHEET	1 OF 1