

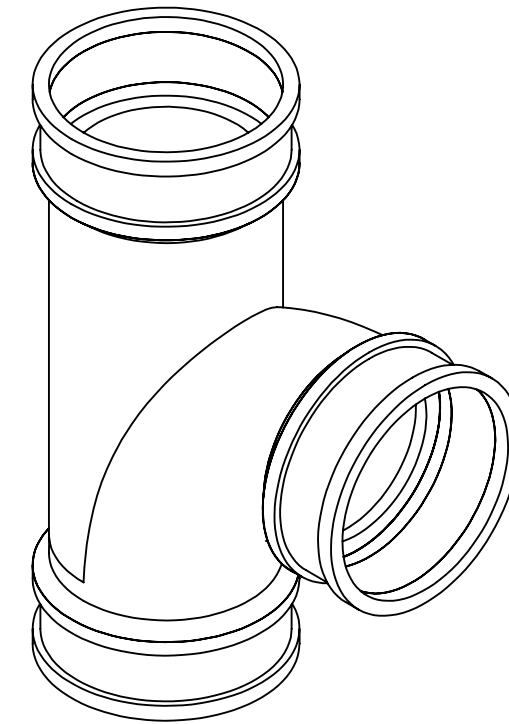

300 S. DAYTON ST.  
 DAVISON, MI 48423  
 PH: 810-653-9626  
 FAX: 810-654-2616

# QT-200

DESCRIPTION: Qwik Tee 2" x 2" x 2" Cast Iron, Plastic, Steel, Copper and Lead to the same

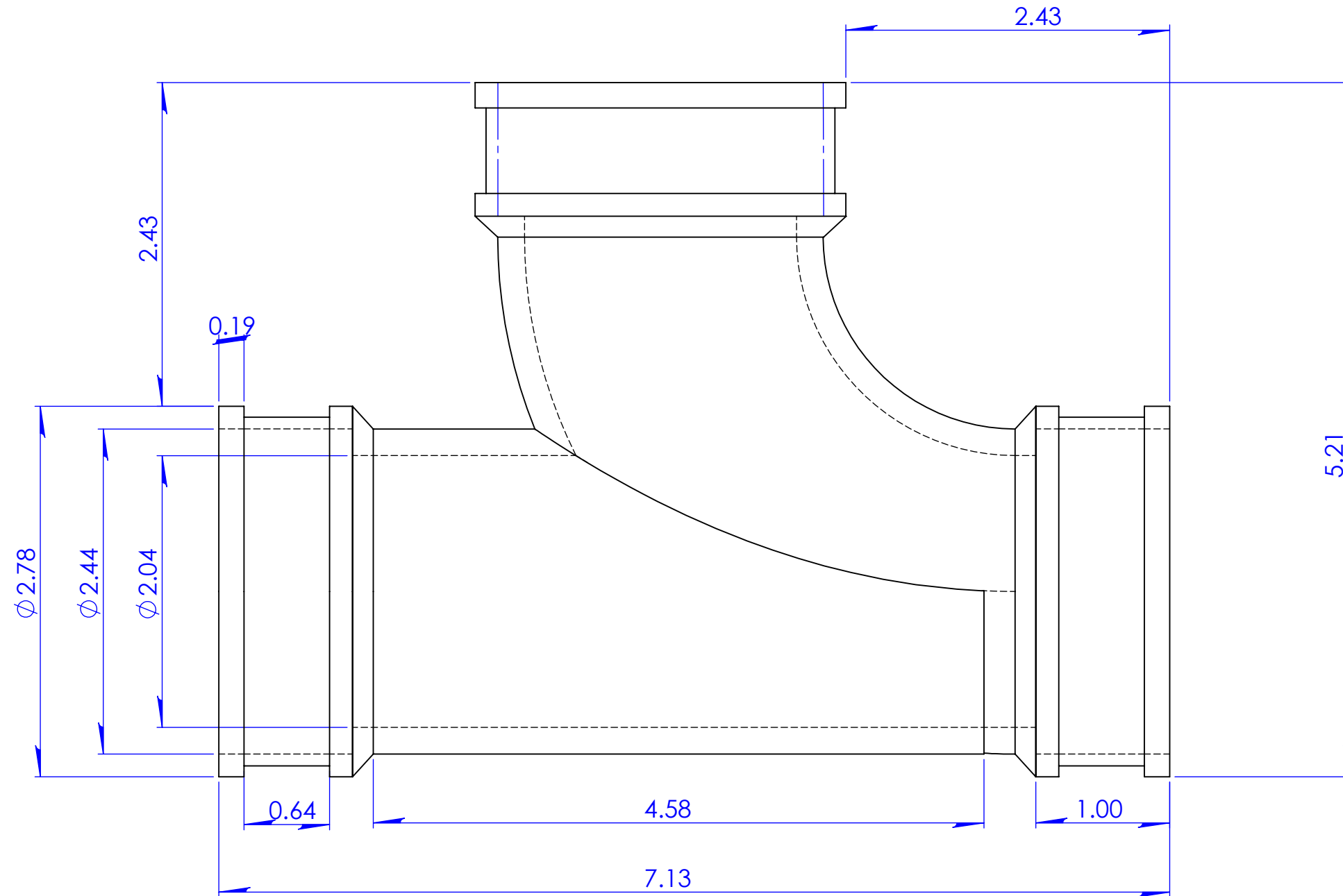

**DRAINAGE SOLUTIONS, INC**

(317) 346-4110

www.drainagesolutionsinc.com

PROPRIETARY AND CONFIDENTIAL  
 THE INFORMATION CONTAINED IN THIS  
 DRAWING IS THE SOLE PROPERTY OF  
 FERNCO, INC. ANY REPRODUCTION IN  
 PART OR AS A WHOLE WITHOUT THE  
 WRITTEN PERMISSION OF FERNCO, INC.  
 IS PROHIBITED.

**TOLERANCES:**  
 .X= Fractional ±  
 .XX= ±.06  
 ANG.= +3°  
 UNLESS OTHERWISE SPECIFIED

Part Weight	0.88 lbs.	Installation Torque	60" Lbs.
Min/Max Temp.	-30/140 Degrees F	Conforms to ASTM	D5926
Pressure Tested	4.3 PSI	Clamps used	300 Series
Material	Flexible PVC 60 Duro Shore A	Box Quantity	20

UNITS:	INCHES
SIZE:	<b>A</b>
DESIGNER:	D. Brady
CHECKER:	
DATE:	6/8/2011
SCALE:	not to scale
3RD ANGLE PROJECTION	
DO NOT SCALE DRAWING	

DESIGNER:	D. Brady	SCALE:	not to scale
CHECKER:		DATE:	6/8/2011
		SHEET 1 OF 1	