

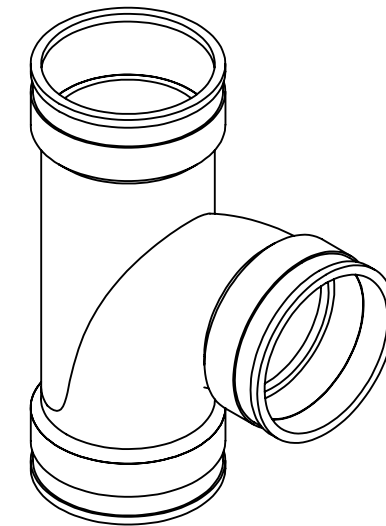

300 S. DAYTON ST.
 DAVISON, MI 48423
 PH: 810-653-9626
 FAX: 810-654-2616

QT-400

DESCRIPTION: Flexibel Tee 4" x 4" x 4" Cast Iron, Plastic, Steel, Copper or Lead

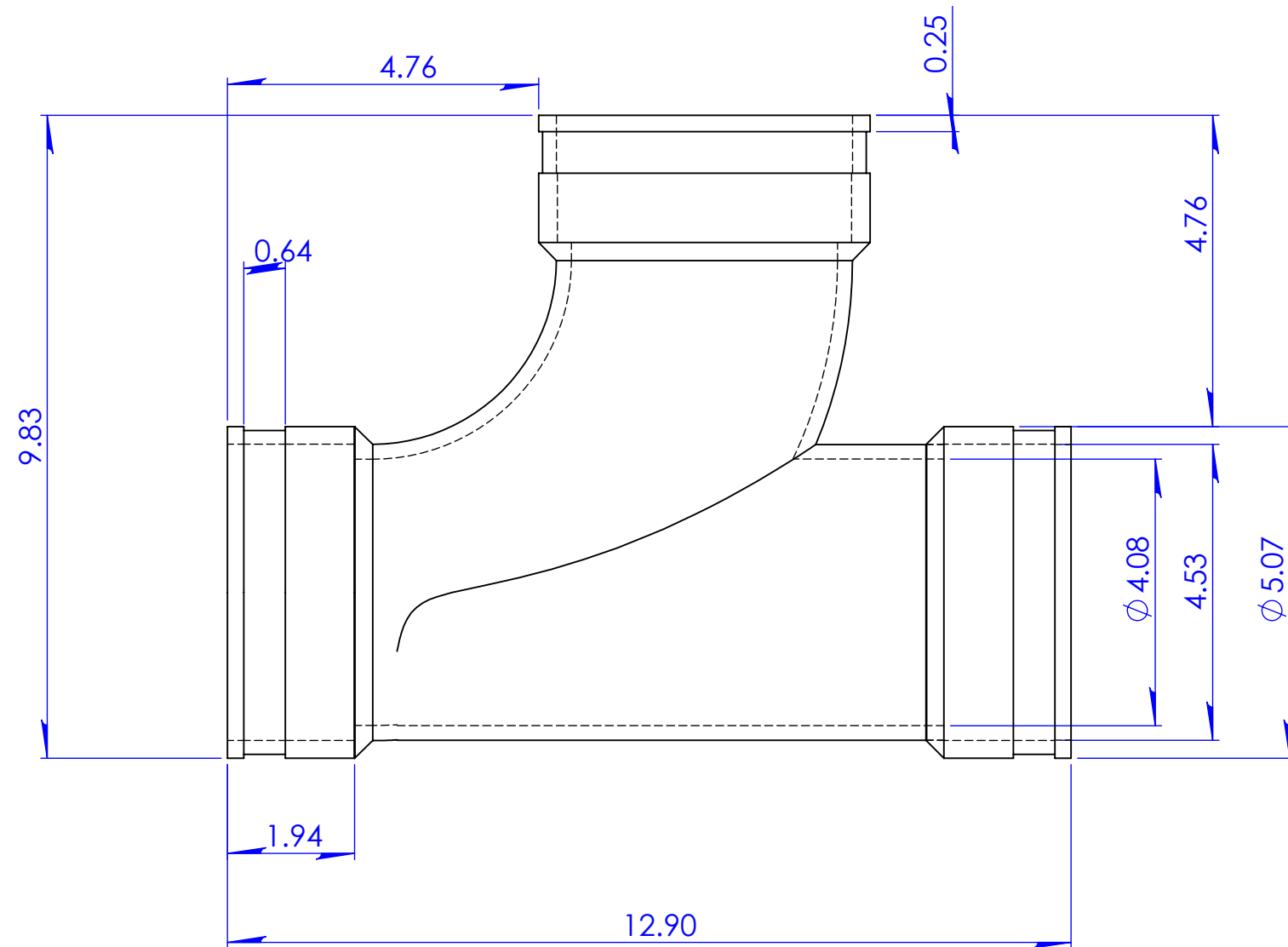

DRAINAGE SOLUTIONS, INC.

(317) 346-4110

www.drainagesolutionsinc.com

TOLERANCES:
 .X= Fractional ±
 .XX= ±.06
 ANG.= +3°
 UNLESS OTHERWISE SPECIFIED

Part Weight	3.46 lbs.	Installation Torque	60" Lbs.
Min/Max Temp.	-30/140 Degrees F	Conforms to ASTM	D5926
Pressure Tested	4.3 PSI	Clamps used	300 Series
Material	Flexible PVC 60 Duro Shore A	Box Quantity	

UNITS:	SIZE:
INCHES	A
3RD ANGLE PROJECTION	
DO NOT SCALE DRAWING	

DESIGNER:	DATE:
D. Brady	6/2/2011
CHECKER:	

SCALE:
not to scale
SHEET 1 OF 1

PROPRIETARY AND CONFIDENTIAL
 THE INFORMATION CONTAINED IN THIS
 DRAWING IS THE SOLE PROPERTY OF
 FERNICO, INC. ANY REPRODUCTION IN
 PART OR AS A WHOLE WITHOUT THE
 WRITTEN PERMISSION OF FERNICO, INC.
 IS PROHIBITED.