

G:\Technical Resources\New\02-13\1-Product\Tank\Injection\Modded Tank\IM-1060 Generic Drawings\IM-1060 1 AND 2 COMP 3PEC-08032013



(317) 346-4110
www.drainagesolutionsinc.com



INFILTRATOR SYSTEMS INC.
4 Business Park Rd. Old Saybrook, CT 06475
(800) 221-4436

INFILTRATOR IM-1060 TANK
1-COMPARTMENT CONFIGURATION

Drawn by: EMB	Date: 08/05/2013
Scale: NOT TO SCALE	Checked by: DFH
	Sheet: 1 of 1

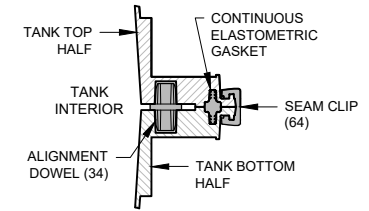
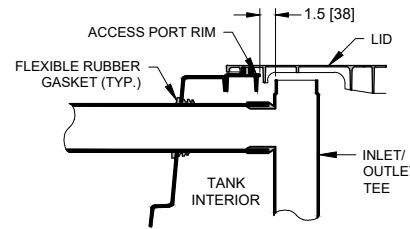
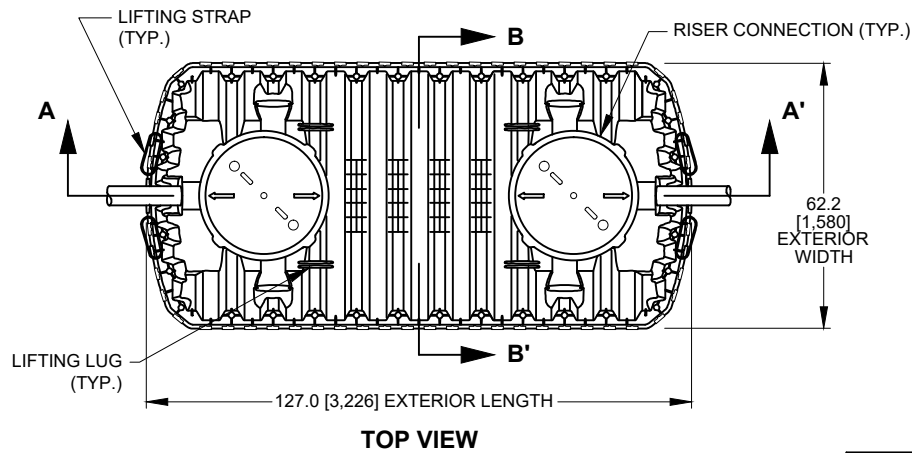

TANK EXTERIOR	
LENGTH	127.0 [3,226]
WIDTH	62.2 [1,580]
HEIGHT	54.7 [1,389]

LIQUID DEPTH	44.0 [1,118]
INVERT DROP	3.0 [76]
FREEBOARD	10.2 [260]

TOTAL CAPACITY	1,247 GAL [4,720 L]
WORKING VOLUME	1,070 GAL [4,050 L]
COMPARTMENT A VOL.	713 GAL [2,700 L]
COMPARTMENT B VOL.	357 GAL [1,350 L]

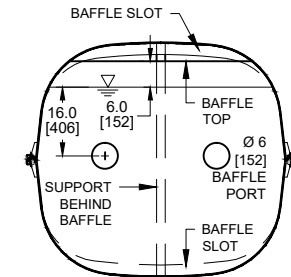
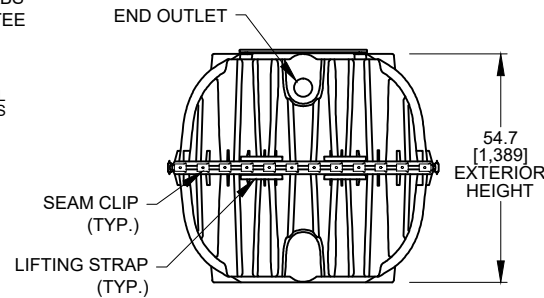
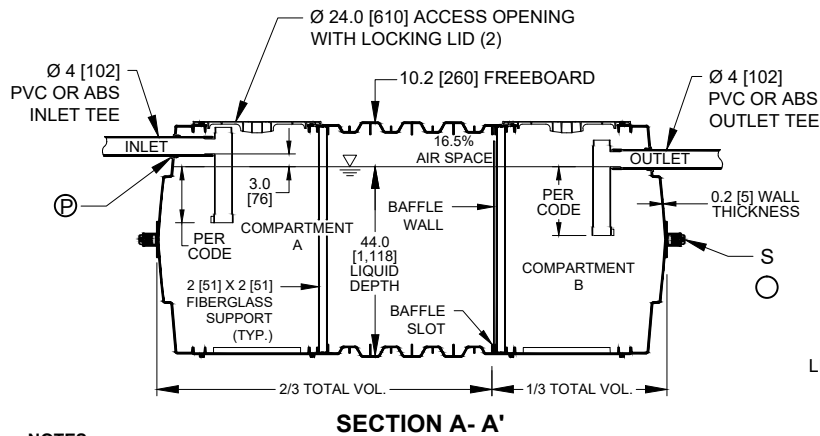

NOTES:

- ALL DRAWING DIMENSIONS IN INCHES [MILLIMETERS] OR AS NOTED.
- EXTERIOR OF ACCESS OPENING LID INCLUDES THE FOLLOWING WARNING IN ENGLISH, FRENCH & SPANISH: "DANGER DO NOT ENTER: POISON GASES."
- TANK MARKINGS WILL INCLUDE: MANUFACTURER NAME, MODEL NUMBER, LIQUID CAPACITY, DATE OF MANUFACTURE, MAXIMUM BURIAL DEPTH, INLET, AND OUTLET.
- MAXIMUM BURIAL DEPTH IS 48 in [1,219 mm].
- MINIMUM BURIAL DEPTH IS 6 in [152 mm].
- MAXIMUM VEHICLE LOAD IS 4,500-lb [20-kN] AXLE LOAD.
- TANK IS FOR NON-TRAFFIC APPLICATIONS.
- AIRSPACE IS 16.5%.
- OUTLET TEE IS COMPATIBLE WITH EFFLUENT FILTER.
- INTERIOR LENGTH TO WIDTH RATIO IS 2.3:1 (118.8-INCH INTERIOR LENGTH / 51.7-INCH INTERIOR WIDTH = 2.3).
- FREE VENT AREA BETWEEN TOP OF BAFFLE WALL AND BOTTOM OF TOP BAFFLE SLOT IS 39.7 in².
- BAFFLE WALL THICKNESS IS 0.31 in [8 mm].

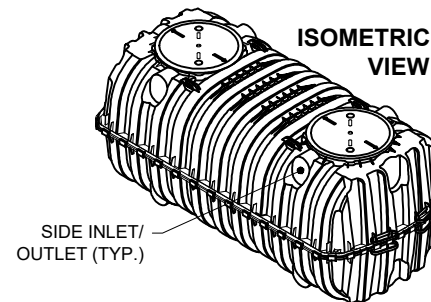

INFILTRATOR SYSTEMS INC.
4 Business Park Rd. Old Saybrook, CT 06475
(800) 221-4436

**INFILTRATOR IM-1060 TANK
2-COMPARTMENT CONFIGURATION**

Drawn by: EMB	Date: 08/05/2013
Scale: NOT TO SCALE	Checked by: DFH
Sheet: 1 of 1	