

ELV DUPLEX-SERIES

Duplex Pump System

Liberty Pumps®

A Family and Employee Owned Company

OilTector®



DRAINAGE SOLUTIONS, INC

(317) 346-4110

www.drainagesolutionsinc.com

1/2 hp, 3/4 hp, 6/10 hp pumps

Duplex pump system detects oil and water, allowing for diversion of oil to a separate tank via dedicated oil and water pumps. (Basin is an optional add-on.)

For use in elevator pits, vaults and other areas requiring the control of oil discharge from sump water.

Features

- Pumps available in 1/2 hp, 3/4 hp and 6/10 hp
- Flow rates to 95 GPM and heads to 65' (depending on model)
- Single and three-phase pump models available
- Complete system ships with control panel, remote alarm, level sensor, junction box with disconnects, 2 reducer couplings, 2 brass check valves and pumps. (Systems with oil holding tank also available!)
- OilTector® control features advanced touch screen display and programming
- Dry contact outputs for alarm conditions
- Preset level sensor for easy installation
- Advanced system monitors/verifies the amount of fluid pumped and that it was pumped to the correct location
- Controls are available with optional BACnet Gateway for integration with building automation and control systems. Please contact Liberty Pumps for more information



innovate. evolve.

OilTector®

Features and Operation

The OilTector® duplex pump system pairs a touch screen controller with two proven Liberty Pumps sump pumps to eliminate unwanted water from elevator sumps, garages, vaults and other areas where preventing the unwanted discharge of oil to the environment is required.

The OilTector® controller features a pre-set level sensor which consists of 3 metal probes and a float switch which

will control two Liberty Pumps sump pumps, one designated for water service, and one for oil service. When water collects in the sump and contacts both the lowest and the middle probe, the water service sump pump will discharge the water until the level is below the lowest probe. If the water level increases to the highest probe, the high water alarm sounds signifying a high inflow condition or faulty pump.

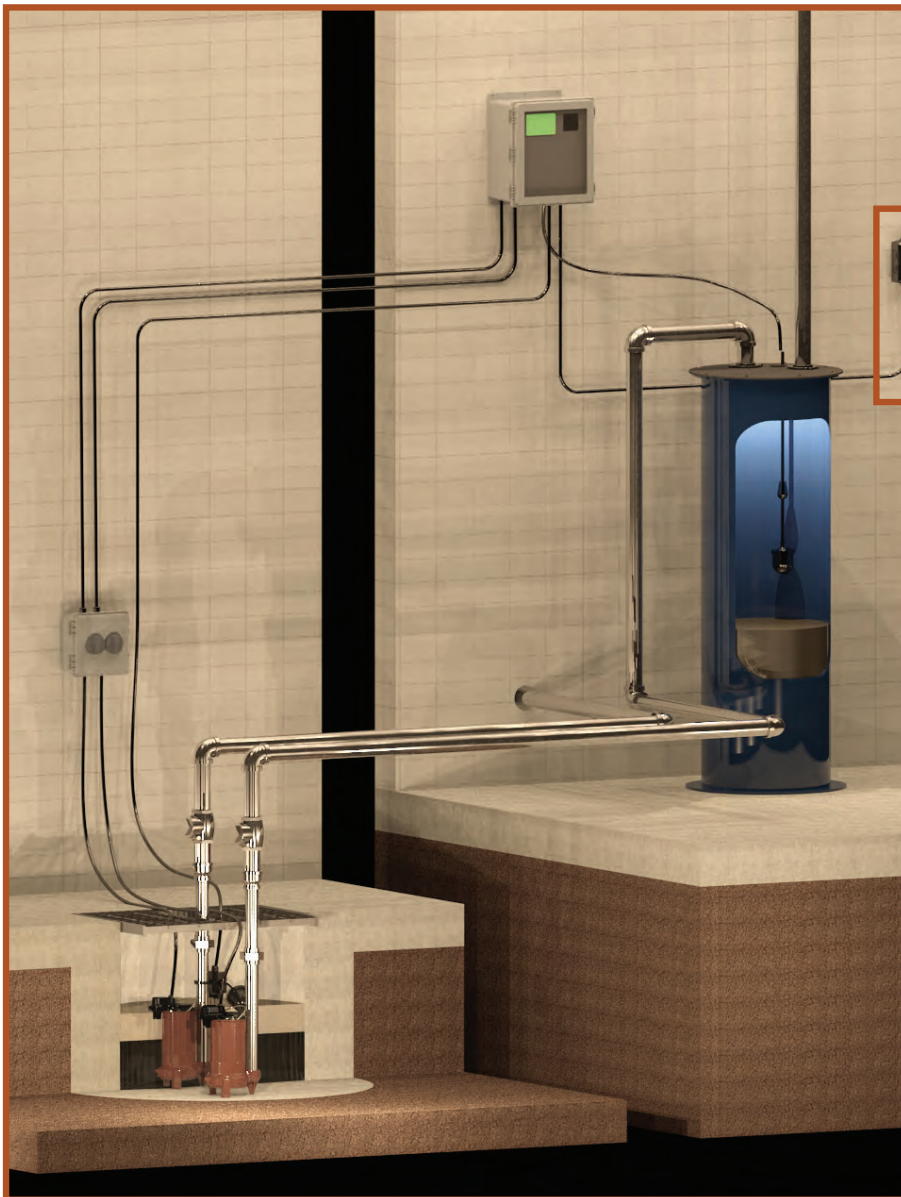

Alarm located up to 2,500' from panel

In the event of an oil leak, the spilled oil will collect in the sump and float on the surface of the water. Once the layer is thick enough to trip the high oil float, the pump will eliminate the oil and water in the sump; the water will be pumped to the drain and then the oil will be routed to the waste oil storage tank preventing unwanted contamination.

The OilTector® controller additionally provides a means for manual pump operation, dry contacts for alarm conditions and data logging to document all operational activity.

Duplex Control Panel Features

Easy-to-use touch screen programming with adjustable display brightness.

Clear cover panel with locking hasp.

Logic in the panel monitors how much water and/or oil is pumped and verifies that it is pumped to correct location.

The Duplex program is designed to run 2 pumps, one oil and one water. Specific pumps run depending on input from the OilTector® pre-programmed sensor. An oil storage display is time-based using the pump's gallon-per-minute rating and dimensions of the holding tank as input by the user.

Data logging allows export of events to Excel® spreadsheet for expanded analysis and documentation.

Controls are available with optional BACnet Gateway for integration with building automation and control systems. Please contact Liberty Pumps for more information.

Control Panel Dimensional Data

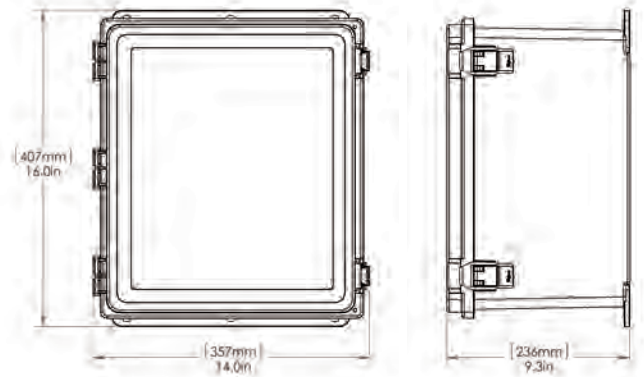

Control Panel Specifications

- Control input 115V, 60 Hz (Single-phase only)
- Pump input 115/230 Single-phase or 230/460V 3-phase, 60 Hz
- NEMA 4X panel enclosure rating
- Maximum pump amps is 15A for single-phase and 4-6.3A for 3-phase
- Pump Off/Auto switch
- Pump elapsed time meter
- Pump run counter
- Pump off/delay time: adjusts pumps run-time when oil is detected
- Pump status light GREEN=ON, RED=STOP
- Oil storage level indicator
- Display alarm banners for:
 - Fail • High Water • Oil Alarm • Power Fail
- Preset level sensor with 25' of cord
- Remote mount alarm (indoor) can be mounted up to 2,500' from panel
- Float switch for oil level sensing in storage tank included with control system

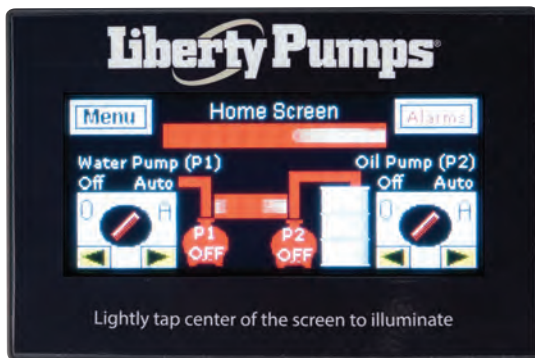

Data Event Log Records

- Pump ETM
- Pump ETM Minutes
- Maintenance Clock
- Pump Run Count
- Pump Cycle Time
- HOA Status
- Amp Status
- Oil Status
- Previous Count Cycle Time

ELV Duplex-Series

OilTector®



Junction Box with Pump Disconnects NEMA 4X

Complete System

Complete system - includes pumps, control panel, level sensor, junction box with disconnects, check valves, reducer couplings and remote alarm (no holding tank)

MODELS	HP	VOLTS	PHASE	HOLDING TANK	WEIGHT IN LBS
ELV280-D	1/2	115	1	No	119
ELV280HV-D	1/2	230	1	No	119
ELV290-D	3/4	115	1	No	119
ELV290HV-D	3/4	230	1	No	119
ELVFL63-D	6/10	230	3	No	158

Complete systems as above with 59 gallon oil holding tank

ELV280-DT	1/2	115	1	YES	184
ELV280HV-DT	1/2	230	1	YES	184
ELV290-DT	3/4	115	1	YES	184
ELV290HV-DT	3/4	230	1	YES	184
ELVFL63-DT	6/10	230	3	YES	223

Oil Tank included with these systems

OilTector® Control System Only (No pumps or tank)

MODELS	VOLTS	PHASE	MAX AMPS	PANEL STYLE	STYLE	WEIGHT IN LBS
OTC-120/230-D	115/230	1	15	NEMA 4X	Touch Screen	36
OTC-230-3-D	230	3	4-6.3	NEMA 4X	Touch Screen	36

Above OTC control systems include control panel, remote alarm, level sensor, and junction box with disconnect. Controls are available with optional BACnet Gateway for integration with building automation and control systems. Please contact Liberty Pumps for more information.

Oil Waste Holding Tank
18" X 54"
59 Gallons

Other sizes available
consult
factory



Performance Curve

