

Introduction

Read all instructions thoroughly. Installation of the OilTector must comply with all Federal, State and Local Codes, Regulations and Practices. The OilTector must be installed by qualified personnel familiar with all applicable local electrical and mechanical codes. Refer to the National Electrical Code (NFPA 70). Failure to properly install and test this product can result in personal injury or equipment malfunction.

The OilTector control system is designed and approved for the safe operation of pumping, alarming and monitoring of elevator sump pits, transformer vaults and leachate well applications. The OilTector will activate a pump to remove water from elevator pits in accordance with ASME A17.1. The OilTector stops the pump before oil or other harmful substances enter our water supply. Indicator lights will illuminate on the control panel for the following: power, pump running, high water, high oil. The panel has a set of auxiliary contacts that activate on power loss or high Oil/Water conditions. These contacts can be connected to the OilTector remote panel which contains audio/visual alarming along with auxiliary contacts for connection to building automation system or SCADA system. The recommended minimum sump size is Ø18" x 30" high.

Safety Guidelines



1. DO NOT USE WITH FLAMMABLE OR EXPLOSIVE FLUIDS SUCH AS GASOLINE, FUEL OIL, KEROSENE, ETC. DO NOT USE IN EXPLOSIVE ATMOSPHERES. PROBE/FLOAT SWITCH SHOULD ONLY BE USED WITH WATER.
2. DO NOT HANDLE THE OILTECTOR SYSTEM WITH WET HANDS OR WHEN STANDING ON A WET OR DAMP SURFACE OR IN WATER.
3. DISCONNECT ALL ELECTRICAL SERVICE BEFORE WORKING OR HANDLING THE OIL ALERT SYSTEM.
4. INCOMING VOLTAGE MUST MATCH OILTECTOR SYSTEM VOLTAGE.
5. TO PREVENT ELECTRICAL SHOCK AND EQUIPMENT MALFUNCTION, USE ONLY WITH A PUMP SUPPLIED WITH A GROUNDING CONDUCTOR AND GROUNDING-TYPE ATTACHMENT PLUG. BE CERTAIN TO PLUG THE OILTECTOR PANEL INTO A PROPERLY GROUNDED, GROUNDING-TYPE RECEPTACLE.
6. CONTROL PANEL AND ALARM MUST BE MOUNTED INDOORS. FOR OUTDOOR APPLICATIONS CONSULT FACTORY.
7. SECURE LEVEL SENSOR ON DISCHARGE PIPE AT A LEVEL THAT GUARANTEES PARTIAL PUMP SUBMERSION WHEN WATER LEVEL IS JUST BELOW THE "OFF" PROBE (THE LONGEST PROBE). (See Figure 5 on page 3 of this manual). FAILURE TO PROPERLY MOUNT THE LEVEL SENSOR MAY CAUSE THE PUMP TO ACTIVATE EVEN WHEN OIL IS PRESENT IN THE SUMP.
8. CAUTION! REMOVE ANY FLOAT SWITCH THAT IS CURRENTLY USED OR SUPPLIED WITH THE PUMP. IF THE FLOAT CANNOT BE REMOVED, SECURE SWITCH SO THAT IT IS ALWAYS ON.

Part Numbers

OTC-115 - OilTector 115 volt Oil Sensor Control System (Control Panel, Alarm Panel, Level Sensor). NEMA 1 enclosure.

OTC-230 - OilTector 230 volt Oil Sensor Control System (Control Panel, Alarm Panel, Level Sensor). NEMA 1 enclosure.

Description of Operation

On water rise, level reaches pump “start” probe to start the pump. Pump will remain on until level is below “off” probe. The “off” probe senses air or oil and turns the pump off so the oil layer will not be pumped out of the sump. If the liquid level reaches alarm probe and mechanical float, the system will differentiate between water and oil and activate the remote alarm.

Installation of the Control Panel

1. It is highly recommended to mount the control panel in the same area as the sump pump to eliminate any splicing of sensor and pump wires. See “Installation of Preset Level Sensor Holder” for more information on splicing.
2. Determine mounting location for the control panel. Mount panel at the desired location making sure the mounting location of the control panel is within 6 feet of electrical receptacle.
3. Plug pump cable into control panel receptacle cable. Plug power cable into receptacle only when ready for testing. See Testing System installation.
4. If the panel is to be installed with conduit, the cables and cord seals must first be removed. Please make note of wire locations. The incoming power (115V or 230V) is connected to L1 and L2 of the contactor, pump receptacle is T1 and T2 on the contactor. Low voltage cable from the level sensing module: green - TB1 off probe, yellow - TB2 start probe, red - TB3 alarm probe, white - TB4 float, black - TB5 float, TB 6 Shield. Low voltage auxiliary contacts are C, O & W. Do not mix low voltage probe wires or auxiliary contacts in high voltage conduits. See figure 1 and figure 3.

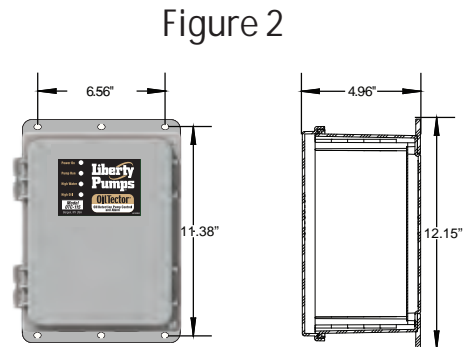
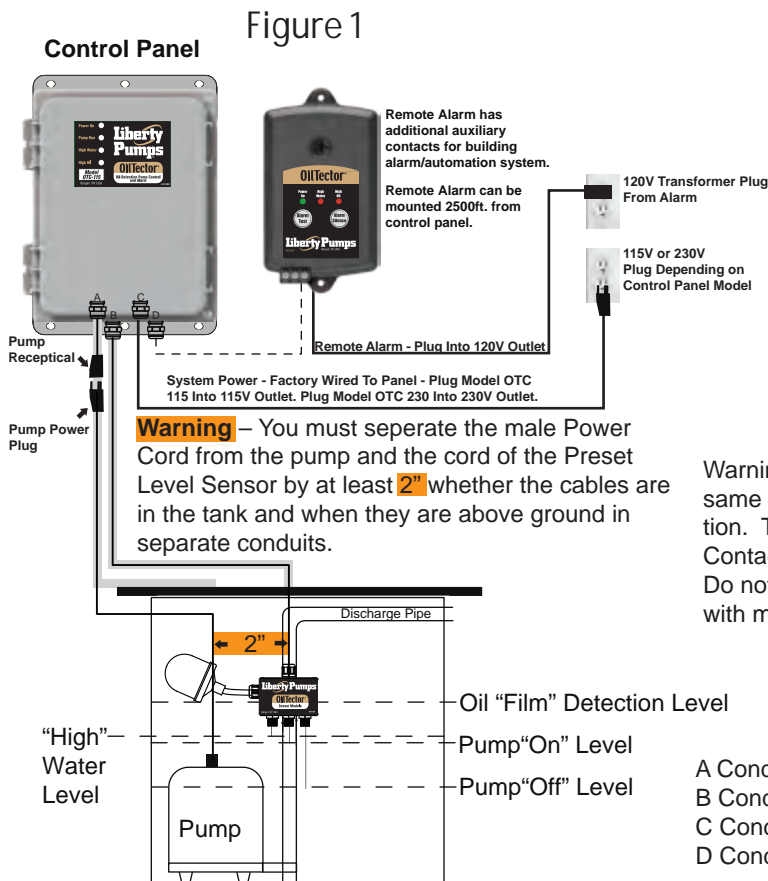

Warning – Do not mix high and low voltage wires in the same conduit, failure to do so will cause system malfunction. The Preset Level Sensor and Auxiliary Contact wires are low voltage class 2 wires. Do not install sensor cables in conduits with main power or pump cables.

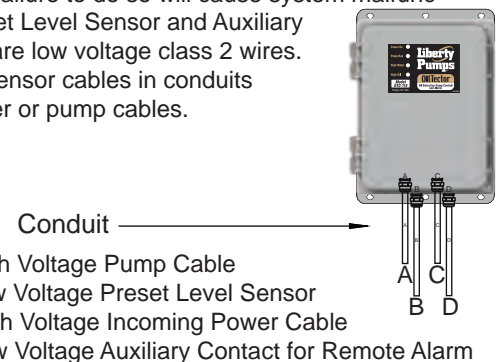

Installation of Preset Level Sensor Holder

1. Review figures 4, 5 and 6.
2. Attach sensor holder to discharge pipe or separate pipe (mounted to side wall) using the stainless steel pipe clamp. Make sure sensor is clear of inlet water and at least 2 inches away from any conductive material. Make sure the bottom probe (off level) is at the same height as the top of the pump or just slightly below ensuring submergence of the pump. See figure 5.
3. Route the five conductor cable to the control panel through the liquid tight cord connector and tighten compression nut.
4. Connect the wires from the level sensor to the terminal strip inside the control panel. See figure 6.
5. If splicing on sensor cable is required:
 - A. For any splicing longer than 100 feet, consult factory.
 - B. Use liquid tight junction boxes and appropriate liquid tight connectors and/or conduit.
 - C. Do not mix high & low voltage circuits in same junction box or conduit
 - D. For level sensor splice, it is recommended to use 3 pair-twisted 22 AWG shielded cable.

Figure 6
Circuit Board

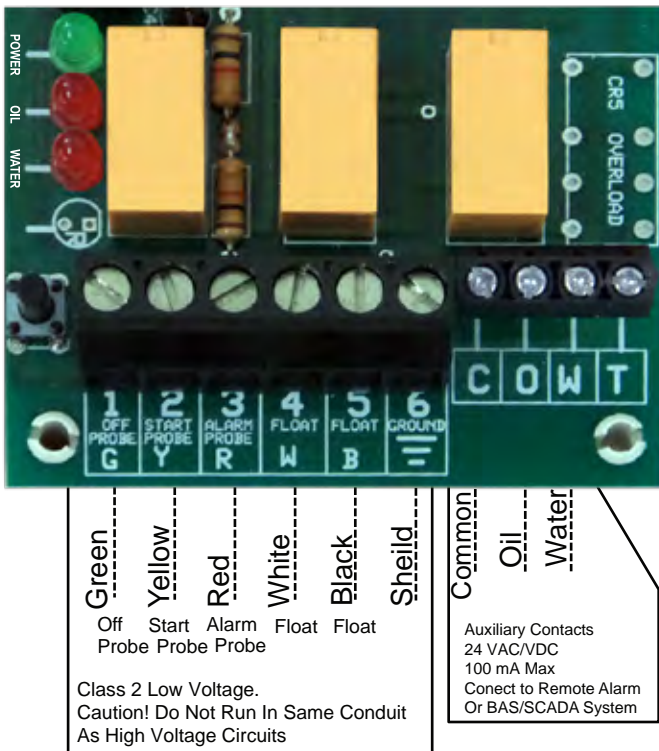

Figure 4

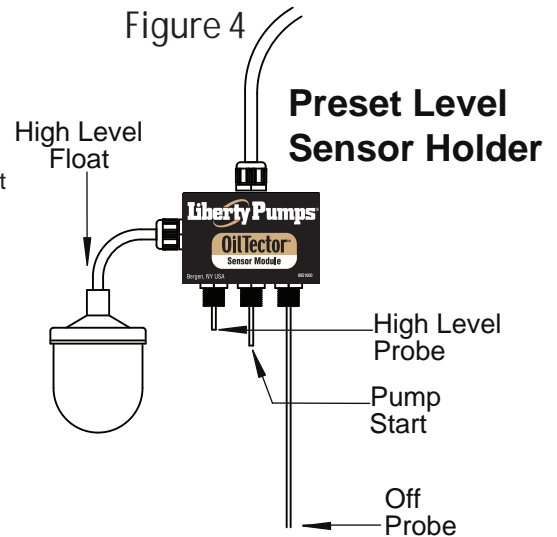
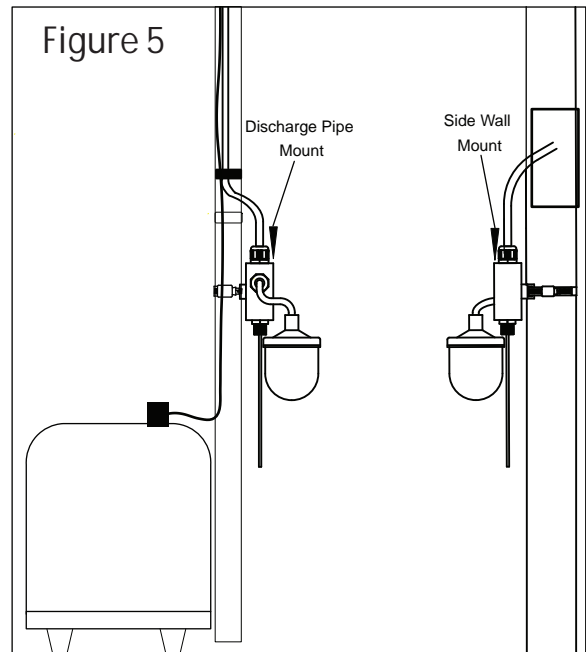
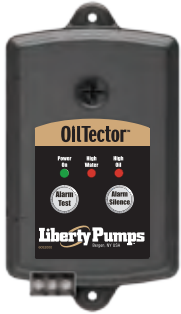

Figure 5



Introduction



Before proceeding with the installation or operation of the Oil Tector Remote Alarm, read all instructions thoroughly, as well as complying with all Federal, State and Local Codes, Regulations and Practices. The Oil Tector Remote Alarm must be installed by qualified personnel familiar with all applicable local electrical and mechanical codes. Refer to the National Electrical Code (NFPA 70). Failure to properly install and test this product can result in personal injury or equipment malfunction.

Safety Guidelines



1. DO NOT USE WITH FLAMMABLE OR EXPLOSIVE FLUIDS SUCH AS GASOLINE, FUEL OIL, KEROSENE, ETC. DO NOT USE IN EXPLOSIVE ATMOSPHERES.
2. REMOTE ALARM MUST BE MOUNTED INDOORS. FOR OUTDOOR APPLICATIONS CONSULT FACTORY.

Description of Operation

The OIL TECTOR REMOTE ALARM is powered by 120 VAC coming from standard wall outlets and is transformed to 11 VDC. Installing a 9 Volt battery provides battery back-up.

The Oil Tector Remote Alarm activates on High Oil or High Water from the control panel. Separate dry contacts for High Oil and High Water can be connected to an Auto Dialer, a BAS (building automation system) or SCADA system.

Tools, Supplies and Requirements for Installation (Not Included)

- #1. Phillips screw driver
- #2. (Qty 2) #6 self tapping screws
- #3. Access to 120 VAC power receptacle
- #4. Optional \ plastic anchor if mounting to sheet rock
- #5. Optional 9V battery (used for battery back up if power goes out)
- #6. Optional Wire stripper (used if you need to strip wire to connect to a BAS or SCADA system)
- #7. Optional needle nose pliers if using aux contacts

Installation of the Oil Tector Remote Alarm Continued

1. To install/replace the battery for the backup power feature, remove the access cover (Fig. 1) and install 9 VDC battery (Fig. 2). After installing battery, press the test button (Fig. 3) to activate the alarm to make sure the battery works properly. The power indicator, high oil indicator and high water indicator light should illuminate and the buzzer should annunciate. If using the auxiliary contacts, leave cover off until step 3 is completed. If you are not using them, replace the access cover (Fig 4).



(Fig. 1)



(Fig. 2)



(Fig. 3)



(Fig. 4)

2. Determine mounting location for the Oil Tector Remote Alarm. Make sure power outlet is within 5 feet of the alarm (Fig. 5). Make sure the outlet is in on a separate circuit breaker from any other device and not on a switched receptacle to maintain power integrity. Mount the alarm using two #6 self tapping screws (not included) (Fig. 6). Use #8 plastic anchor for mounting to sheet rock. (Fig. 7).

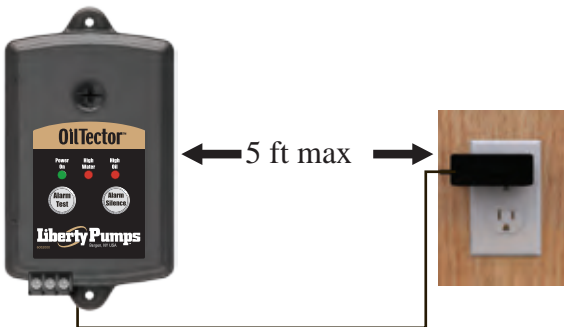

(Fig. 5)

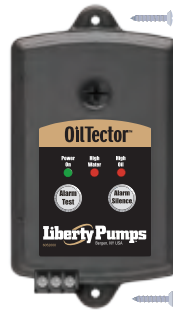

(Fig. 6)



(Fig. 7)

Installation of the ALARM UNIT Continued

3. Continued. If connecting to existing alarm security system or (BAS) system leave terminals + & - open and use 18 gauge 2 conductor wire to connect the existing product to terminals 2A,2B, 1A,1B (Fig. 9). When connected, replace the access cover and pull the wire through the knockouts on the access cover (See Step #4) . **Caution!** - When installing wires, route all wires away from sharp objects & internal components.

Terminals 1A & 1B
High Oil

Terminals 2A & 2B
High Water

Class 2, 24 VDC/VAC (50/60 HZ)
100 Milliamps **MAXIMUM**

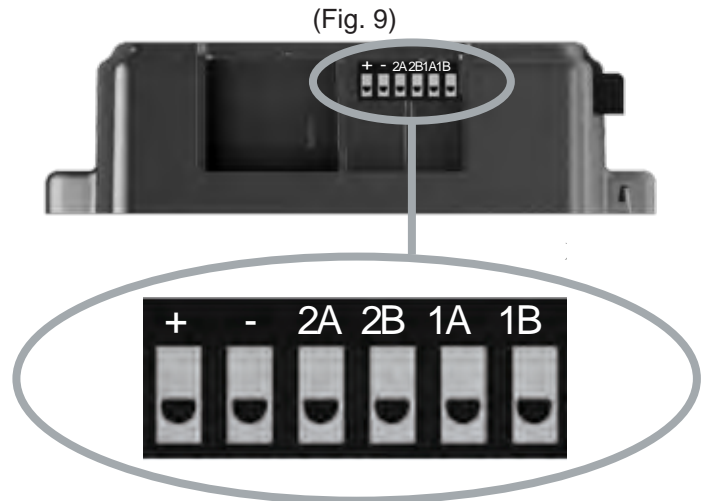

NOTE: The Auxiliary Contacts on the Oil Tector Remote Alarm are Normally Open only.

4. Use a needlenose pliers to remove the desired “break away tabs” from the access cover (Fig. 10). Lightly pull and twist off tab (s). Replace access cover and run wires through the “break aways” (Fig. 11)

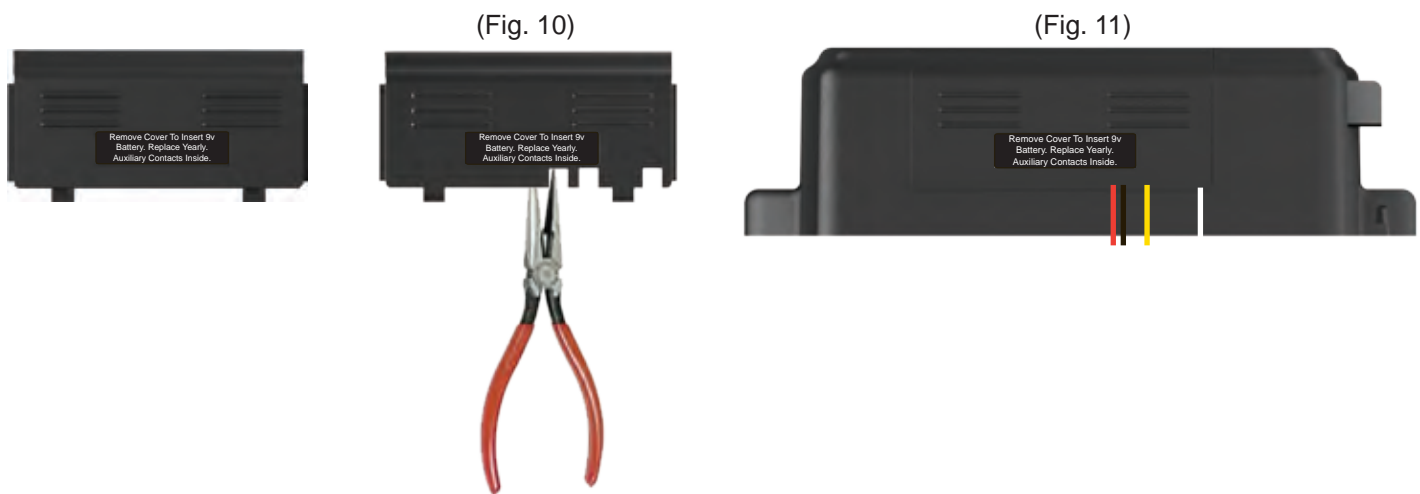

Installation of the Oil Tector Remote Alarm Continued

6. Connect the Oil Tector Remote Alarm to the auxiliary contacts marked C, O & W in the control panel. C on the alarm to C in the panel. O on the alarm to O in the panel. W on the alarm to W in the panel. Use 18 awg, 3 conductor cable. CAUTION: The auxiliary contacts are low voltage wires and cannot be run in a conduit with High voltage wires.

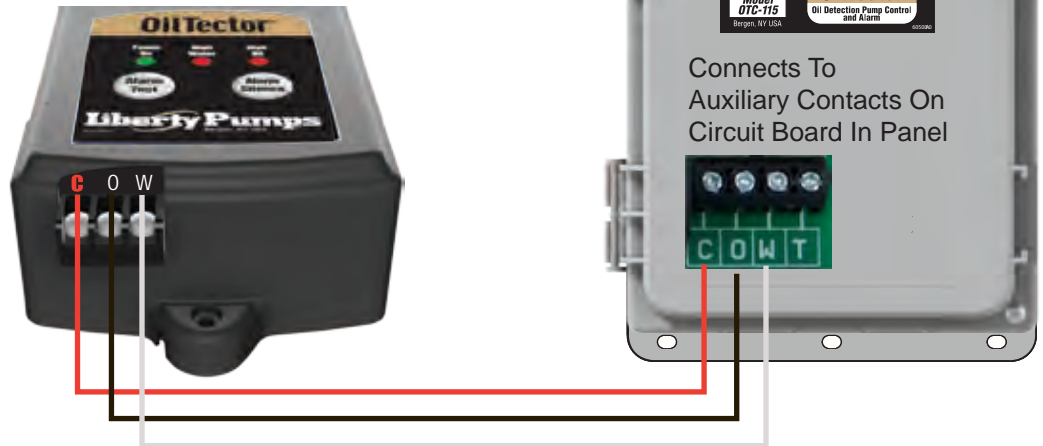

6. Plug in the power supply into a 120VAC, 50/60 HZ standard wall outlet. The green "Normal" light should come on.

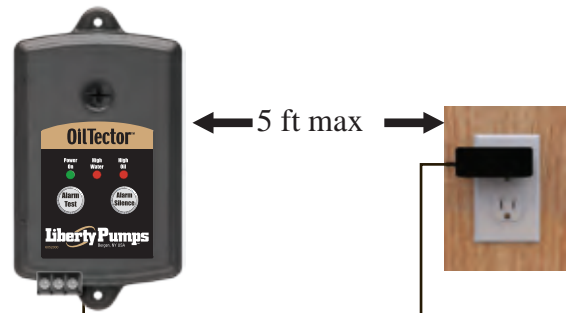

7. Test the system by pressing the "Alarm Test" button. The buzzer, the red "High Water" light & the red "High Oil" light will be "on". Release the "Alarm Test" button and the alarm buzzer and indicator lights will automatically reset. Test product weekly to ensure system integrity.



Testing the complete system Upon complete installation of controls, pump and piping, test the complete system.

1. Test high oil circuit by lifting the float switch with the sump empty of water. Oil is non conductive like "air", and when the float is lifted only the HIGH OIL indicator will be illuminated. The auxiliary contacts in the control panel and the remote alarm will activate.
2. Test a pump cycle by slowly filling tank with water. Stop filling tank with water when the level touches middle probe. When the water touches the middle probe, pump should start and pump down to the bottom probe at which time the pump will stop. Check discharge plumbing for leaks and make sure discharge is going to the correct area.
3. Test high water circuit. Slowly fill the tank until the water level just touches the upper probe. When the water touches all probes, the HIGH WATER indicator will be illuminated. The auxiliary contacts in the control panel and the remote alarm will activate.
4. Test the remote alarm for power loss. Unplug the power cord on the control panel. The auxiliary contacts "C & W" will close and the remote alarm will activate.

Testing panel - Using 5 gallon pail. If it is not possible to test the complete system outlined above, then test the panel operation using a 5 gallon pail filled with water.

1. Before lowering the sensor probe into the pail, lift the float switch, the HIGH OIL indicator (Fig. 1 on this page) will be illuminated. The auxiliary contacts in the control panel and the remote alarm will activate for oil alarm.

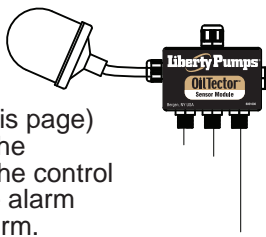

2. (Press down and hold the tact switch on the circuit board - Fig. 2) while lowering the sensor into the bucket so the bottom and middle probes touch the water (Fig 3), the pump should activate. While the pump is activated, slowly remove the sensor probe out of the water until the longest probe is no longer in the water (Fig 4), then let go of the tact switch (Fig 2) and the pump should turn off. Repeat a couple of times for quality assurance.

3. Press down and hold the tact switch on the circuit board (Fig. 2) while lowering the sensor probe into the bucket of water slowly so that the longest probe and the middle probe are immersed in water (Fig. 3) the pump will activate. Continue to lower sensor probe so that water touches the shortest probe (Fig 5), the HIGH WATER indicator will be illuminated (Fig 6). The auxiliary contacts in the control panel and the remote alarm will activate.

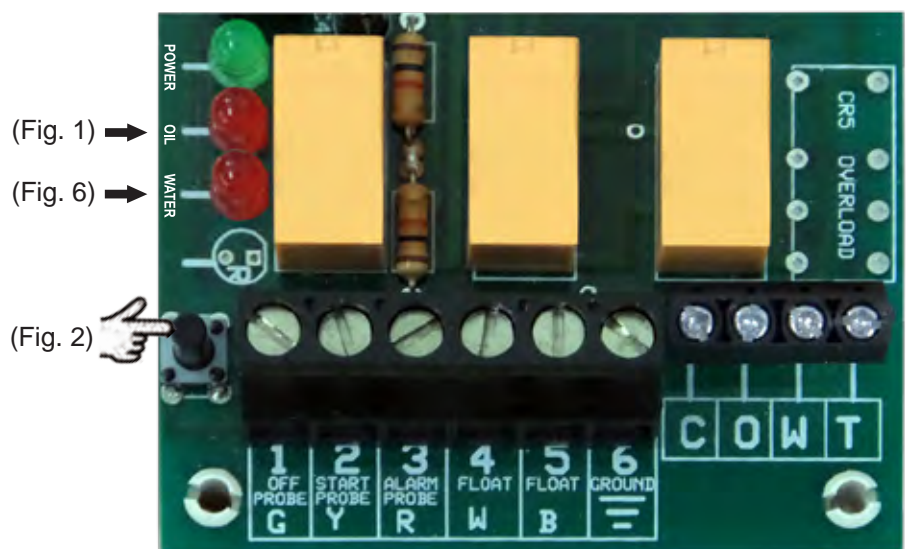
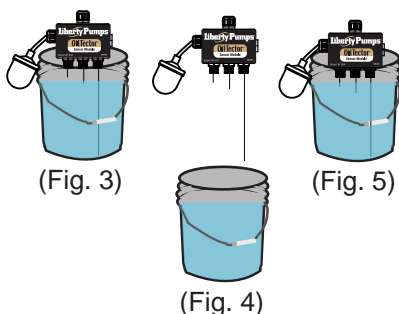

Maintenance

1. The preset level control must be kept clean and free of rust, mud, soap or any conductive material.
2. Every year clean probes keeping them free of debris, calcium or iron deposits.
3. Fuses in control panel are 5mm X 20mm 1 amp for F1
(Spare fuses are included for your convenience)
4. Every year replace 9 Volt Battery in Remote Alarm.

Trouble Shooting

Symptom	Possible Cause	Action
Pump does not run	Panel Power Cord Unplugged Pump not plugged into panel Defective Contactor Loose level sensor wires Pump failure	Plug in Outlet, Check Power Plug pump to panel plug Replace Contactor Tighten connections Replace pump
Pump turns off before bottom probe	Poor pump ground or system ground	Check grounding system
Pump Runs Continuously	Make Sure the Preset Level Sensor cable and the power cord from the pump are separated by at least 2" in the tank and 2" apart running into the control panel.	