

(317) 346-4110 www.drainagesolutionsinc.com

** This drawing was originated by and is the exclusive property of Macon Plastics. It is furnished for recipient's information only and is not an authorization or license to make this construction or furnish this information to others.

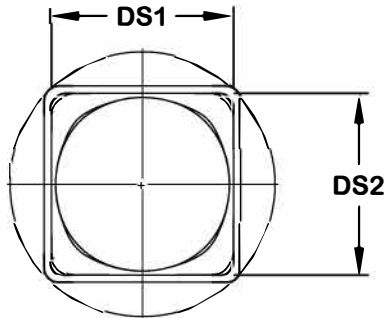
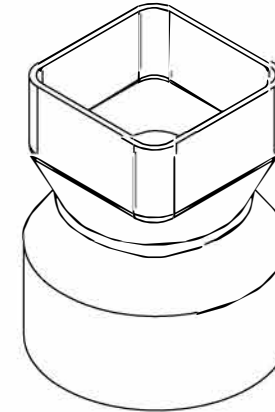
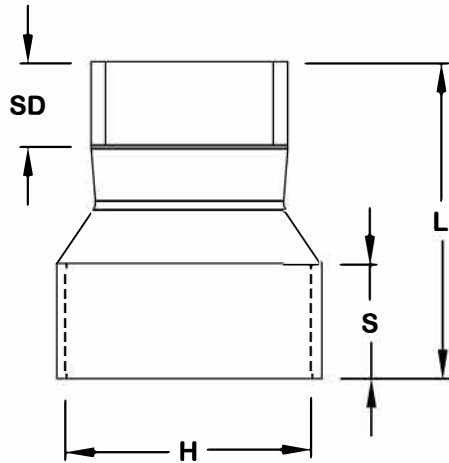

NOMINAL SIZE	PART NUMBER	SD	S	L	H	DS1	DS2
4x4x6	80573	1.7	3.0	8.5	6.6	4.0	4.0
5x5x8	01004	2.2	4.0	10.8	8.6	5.0	5.0
6x6x8	80588	2.6	4.0	11.0	8.6	6.0	6.0
6 ¹ / ₄ x6 ¹ / ₄ x10	N/S	2.6	5.0	12.5	10.8	6.3	6.3
7x7x8	01013	3.2	4.0	10.2	8.6	7.0	7.0
8x8x10	80518	3.2	5.0	14.0	10.8	8.0	8.0
9x9x10	N/S	3.5	5.0	14.3	10.8	9.0	9.0
8x8x12	01097	3.5	5.0	15.0	12.8	8.0	8.0
10x10x12	01173	3.5	5.0	15.0	12.8	10.0	10.0

Description: Square Downspout Adapter

Material: SCH 40

Size: (per chart)

Configuration: Downspout x Hub

* Dimensions are approximate due to various factors affecting production. Dimensions are subject to change without notice due to design or production modifications. Unless otherwise specified, socket bottom to socket bottom dimensions are to be +/-1/2". Overall length dimensions are to be +/-1". All fitting angles are to be +/-1 degree. Outside dimensions are to be +/-1/4".