

10" ROUND GRATE

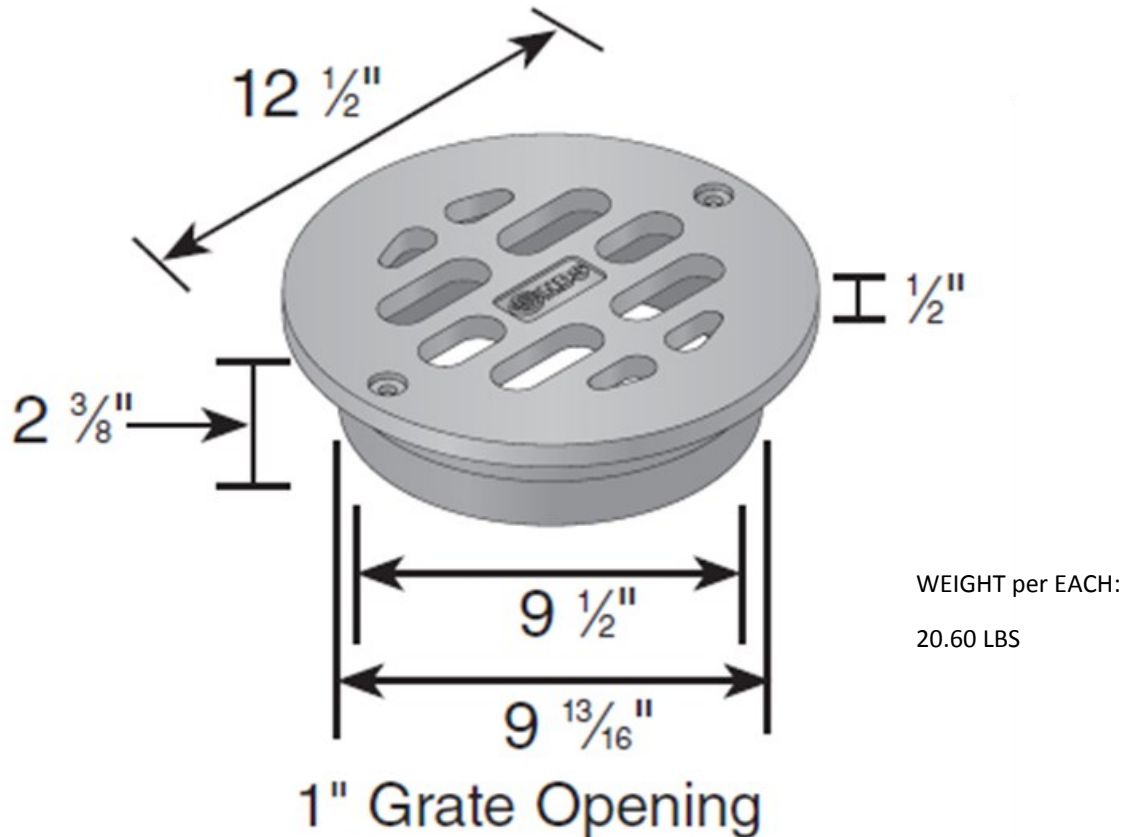

DRAINAGE
SOLUTIONS, INC

(317) 346-4110

www.drainagesolutionsinc.com

Material: Ductile Iron
Colors: Black (D10)
Fits: 10" Corrugated and Sewer and Drain pipe
This is not a custom grate and qualifies for normal NDS freight terms
Opening: 36.82 in² open space
Will accommodate 82.05 gallons per minute with 1/2" of head

Load Recommendation Guide



Class D

- Loads of 326-575 psi.
- Recommended for heavy-duty hard tire forklifts at speeds less than 20 m.p.h., H-20 rated.

