

## 12" x 12" ATRIUM GRATE

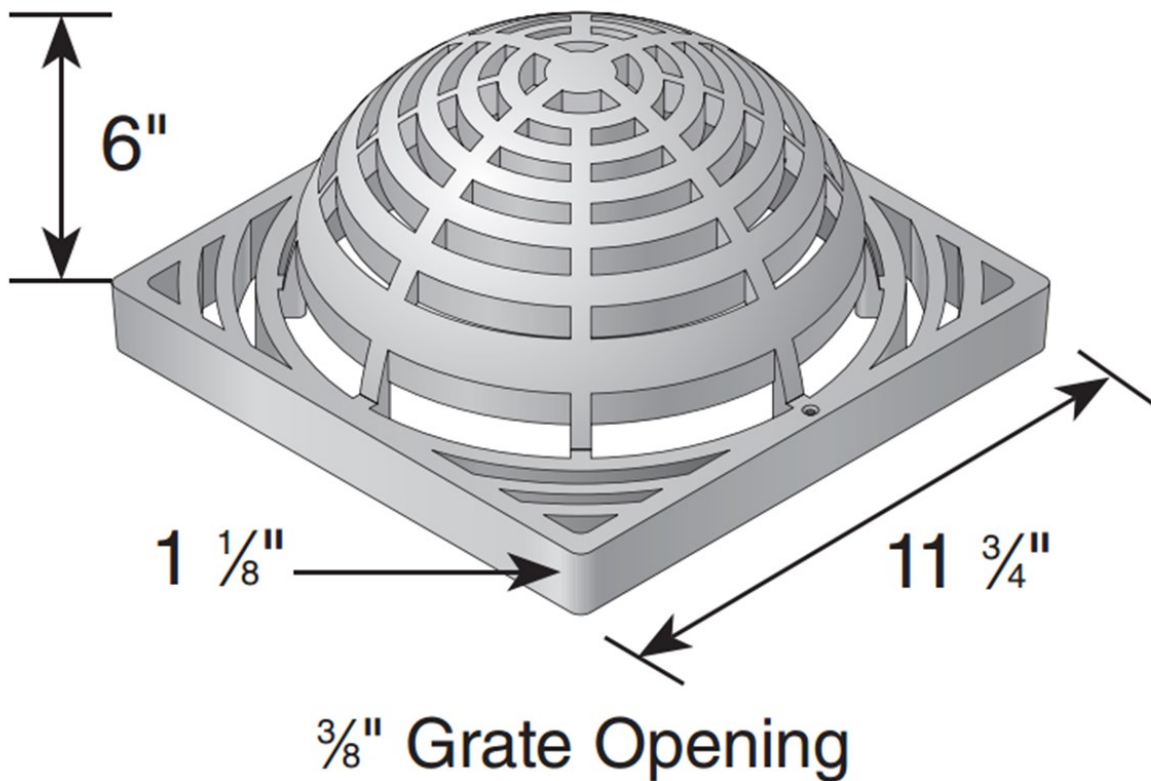

Material: UV Protected High Density Polyethylene (HDPE)

Weight: 1.74 lbs

Colors: Green (1280), Black (1290)

Fits: Use with 12" Catch basin series

Grate Openings: 50.60 in<sup>2</sup>

Will accommodate 154.79 gallons per minute with 1/2" of head



**DRAINAGE**  
SOLUTIONS, INC

(317)346-4110

[www.drainagesolutionsinc.com](http://www.drainagesolutionsinc.com)

