

5 Inch Pro Series Grates

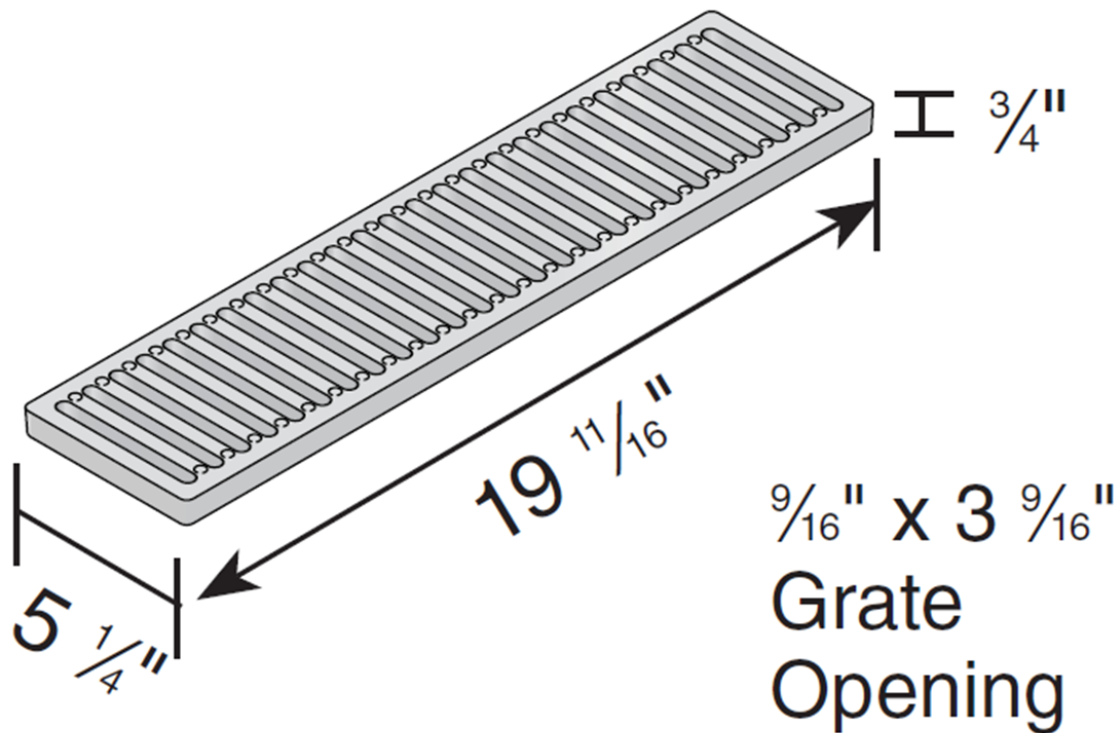

Part #: 823
 Material: Ductile Iron
 Color: Black/Ductile Iron
 Fits: 5" Pro Series Channel, Part# 820 (takes 1 grate) and
 Part# 800 (takes 2 grates)
 Grate Opening: $\frac{9}{16}'' \times 3 \frac{9}{16}''$
 Open Surface Area: 22.90 Sq. Inch per Ft.
 Head Pressure / Flow Rate:
Head (inches) - Max Flow
 $1'' = 99.07 \text{ GPM}$
 $0.5'' = 70.05 \text{ GPM}$
 Weight per each: 12.30 lbs.
 Screw: #829 Stainless Steel Screw, 4 per grate.
 UV Inhibitors



Class D

- Loads of 326-575 psi.
- Recommended for heavy-duty hard tire forklifts at speeds less than 20 m.p.h., H-20 rated.

ADA Compliant